

Circuit Savers



What are Circuit Savers?

Circuit savers are unique Sun cartridges that have been designed to solve numerous, usually specific, hydraulic control or circuit problems. Many of them are not commonly found in any general hydraulic products catalog, and often, if they are available at all, are offered only as custom or specialty products. Most of the products that are included here simply do not fit into any general standard product category.

Design Concepts and Features

Three port, Pilot-to-close Check Valve Cartridges – CO*A and CODD

Sun pilot-to-close CO*A and CODD check valve cartridges allow flow in one direction only, but will stop free flow with the application sufficient pilot pressure. These valves are especially useful in multi-function systems, such as regenerative circuits. (See Figure 1.) Features and performance parameters include:

- The free flow direction is from port 1 to 2.
- The seats are steel for long wear and maximum dirt tolerance.
- The CO*A nominal pilot ratio is 1.8:1 (e.g. 1000 psi [70 bar] at port 3 will hold the valve closed against 1800 psi [125 bar] at port 1, provided the pressure at port 2 is zero.)
- The CODD nominal pilot ratio is 20:1:1 (e.g. 150 psi [11 bar] at port 3 will hold the valve closed against 3000 psi [210 bar] at port 1, provided the pressure at port 2 is zero.)
- Any pressure at port 2 directly opposes pilot pressure.
- The CO*A versions are available in five frame sizes, with flows up to 160 gpm.
- The CODD cartridge is available in series 1 frame size only, and capacity is the equivalent of a 0.11 in. (2,8 mm) dia. orifice.
- Maximum leakage is 1 drop/min (0,07 cc/min).

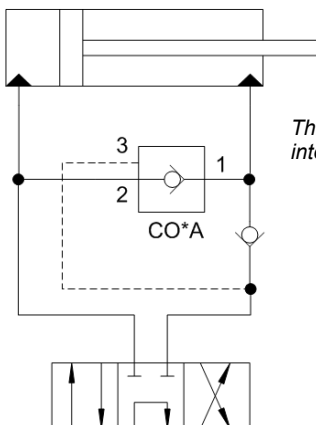

This drawing is not a real circuit and is intended for description only.

Figure 1.
A CO*A pilot to close check valve is commonly used in a regeneration circuit.

Three port, Pilot-to-close Check Valve Cartridges – COFO

Sun pilot-to-close COFO-XDN check valve cartridges are similar to CO*A cartridges with the following exceptions:

- Available in series 2 frame size only.
- Flow capacity is 0.6 gpm (1,27 L/min).
- The nominal pilot ratio is 120:1 (e.g. 30 psi [2 bar] at port 3 will hold the valve closed against 3600 psi [252 bar] at port 1, provided the pressure at port 2 is zero.)
- Any pressure at port 2 directly opposes pilot pressure.
- This valve is very useful in accumulator discharge circuits.
- The small flow capacity may make discharge time too long where large accumulators with low pre-charge pressures are involved. (The equivalent orifice diameter is 0.05 in. [1.27 mm]).
- Where higher discharge flows are required, the COFO can be used to pilot a higher flow 2-way valve, such as an LODA.
- Maximum leakage is 5 drops/min (0,3 cc/min).

Two port, Air Bleed and Start-up Cartridges – NQEB

Sun NQEB air bleed and start-up cartridge valves are useful in both reducing start-up power requirements plus facilitating pump priming during initial system start-up, especially with a blocked center circuit. The valve will allow the pump to come up to speed under a light load, purging the system of air, before it closes allowing full system pressure to be established. Performance parameters include:

- System flow and pressure must be greater than 4 gpm (15 L/min), and 80 psi (5,5 bar).
- After air has been purged, closing times vary from approximately 12 seconds at 4 gpm (15 L/min) to 0.5 seconds at 50 gpm (200 L/min). (See Figure 2.)
- The valve will re-open when system pressure drops below 25 psi (1,7 bar).

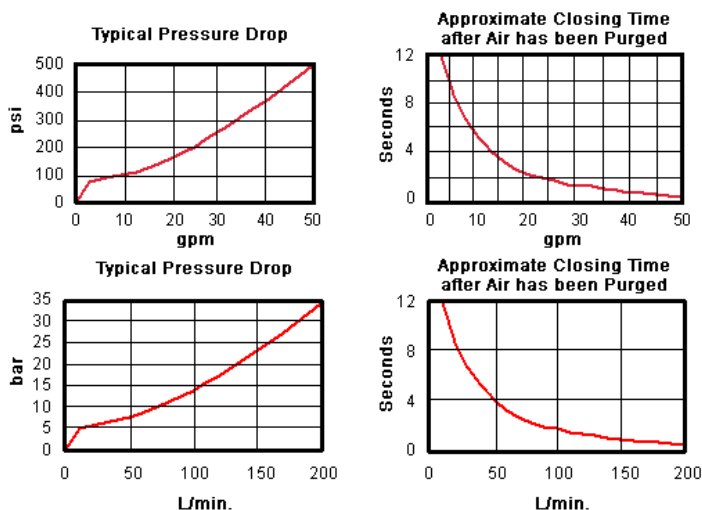

Figure 2.

These NQEB curves show the relationship between flow and time to close after air is purged, as well as overall pressure drop as a function of flow through the valve.

Two port Flow Fuse Cartridges – FQ*A

Sun fixed-orifice FQ*A valves are used to maintain the position of a hydraulic actuator in the event of a hose line break. The valve normally allows flow to and from the actuator but closes instantly if the flow from the actuator exceeds the setting of the valve. Features, circuit considerations and performance parameters include:

- The valve closes when the flow from port 1 to port 2 exceeds the setting of the valve.
- The valve will reset when pressures become equal at both ports.
- With spool type construction, maximum leakage is equal to 2 in³/min at 1000 psi (30 cc/min at 70 bar). *(This leakage could allow some actuator drift to occur.)*
- The flow setting is specified by the customer and is factory set to a tolerance of +/- 10% of the required setting.
- The flow setting should be at least 25% above the maximum system flow.
- It is not advisable to select a valve where the +25% flow rating is at the top end of its flow range. *(There will be no room to increase the flow setting if a higher than expected transient flow develops!)*
- Because these valves respond so rapidly, they can be sensitive to transient flows above the valve setting. *(An example would be the surge in flow if decompression takes place upon actuator reversal.)*
- These valves are available in four frame sizes, with flows up to 50 gpm.

Three port Accumulator Sense, Pump Unload, Pilot Cartridges – QPA*

Sun QPA* pilot valves are primarily used in accumulator circuits to unload a pump when the accumulator has reached the desired maximum system pressure. They have a fixed, user selectable, pilot ratio differential. The differential determines the pressure span between the pump unload pressure and the pump reset (“cut in”) pressure. This differential is expressed as a

percentage of the valve’s pressure setting. Features, circuit considerations and performance parameters include:

- Port 1 is the accumulator sensing port, port 2 is connected to the device controlling the unloading function, and port 3 is connected to drain.
- The pilot flow capacity is 46 in³/min (0,75 L/min)
- When the valve’s setting is reached, port 2 will connect to port 3, thus venting the unloading (relief) valve. When the sensing pressure drops to the reset pressure, as determined by the selected differential, port 2 is blocked, de-venting the unloading valve and loading the pump again.
- There are four user selectable pressure differentials: “A” = 15%, “B” = 20%, “C” = 30%, and “D” = 50%.
- The pressure differential between unload and reset will be within +/- 1% of the stated ratio of the valve, with up to an additional 25 psi (1,7 bar) due to dynamic seal friction.
- When applying this cartridge, a separate drain line is required to prevent erratic operation that can be caused by tank line pressure fluctuations.
- The spool design of this valve allows it to maintain a fixed differential ratio because the areas are created by diameters on the spool that will not wear or change with use.
- Minimum clearances between the spool and sleeve and a seal on the pilot piston diameter significantly reduce the potential for silting.

Four port Accumulator Sense, Pump Unload, Pilot Cartridges with integral Check Valve – QCD*

Sun QCD* pilot valves include an integral check valve at port 1. They are similar to QPA* pilot valves with the following exceptions:

- Port 1 is the pump inlet port, port 2 is the accumulator sensing port, port 3 is connected to the device controlling the unloading function, and port 4 is connected to drain.
- The flow capacity, from port 1 to port 2, for the “A” differential is 12 gpm (45 L/min), while the flow capacity for the “B”, “C”, and “D” differentials is 15 gpm (60 L/min). (At 15 gpm [60 L/min], the pressure drop is 100 psi [60 bar])
- The pilot flow capacity is 46 in³/min (0,75 L/min)
- When the valve’s setting is reached, port 3 will connect to port 4, thus venting the unloading (relief) valve. When the sensing pressure drops to the reset pressure, as determined by the selected differential, port 3 is blocked, de-venting the unloading valve and loading the pump again.

Important notes regarding Accumulator Sense, Pump Unload, Pilot Cartridges:

1. Careful consideration should be given when selecting an adjustment range. Total system pressure drops and flows tend to affect the operation of unloading valves. *(Low operating pressures combined with low differentials result in a very narrow band between unload and reset. High flow rates typically mean high pressure drops, which subtract from the effective differential of the valve.)*
2. Sun has designed a variety of standard accumulator/pump unload assemblies with a variety of features. These assemblies are not currently viewable on the Sun website, but are readily available. If you have an immediate need, please contact your Sun distributor.
3. For additional information, please see Sun Highlight : [“Accumulator Sense, Pump Unload Valves”](#).

**Two port Adjustable Gauge Snubber—
NSAB-KX*-****

The Sun NSAB series adjustable gauge snubber is a simple, effective, throttling and shut-off device used to isolate hydraulic system indicating devices such as gauges and other sensitive instruments. It can be used to positively shut off the gauge from the line pressure, or, when partially opened, reduce or eliminate gauge pointer fluctuation due to line pressure transients. Features include:

- Stainless steel construction (303 and 416 series).
- Finger-tip adjustment knob and lock nut (glass-filled nylon).
- Buna seals standard (Viton seals available).
- Available in eight port selections (e.g. both male/female configuration plus thread size/type).
- Can be used to quickly verify/predict/trouble shoot systems when orifice/pilot flows need to be analyzed or documented (See Figure 3).

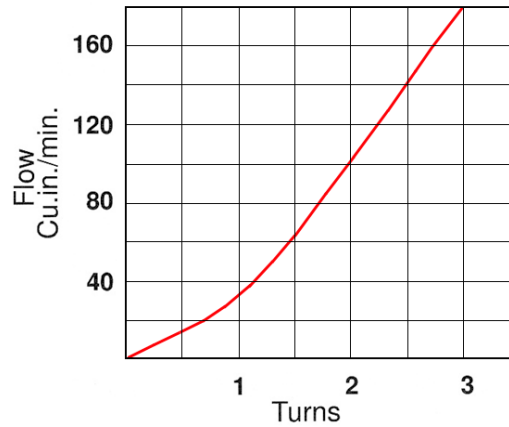

Figure 3.
Flow vs. turns for an NSAB adjustable gauge snubber at a 1000 psi (70 bar) pressure drop (150 SUS fluid).

Circuit Savers Overview

Function	Description	Nominal Capacity	Model	Cavity	Symbol
2 Port	Flow Fuse Valve	6 gpm (23 L/min.) 15 gpm (60 L/min.) 25 gpm (95 L/min.) 50 gpm (200 L/min.)	FQCA FQEA FQGA FQIA	T-13A T-5A T-16A T-18A	
2 Port	Air Bleed Start-up Valve	4 - 50 gpm (15 - 200 L/min.)	NQEB	T-3A	
3 Port	Pilot-to-Close Check Valve	10 gpm (40 L/min.) 20 gpm (80 L/min.) 40 gpm (160 L/min.) 80 gpm (320 L/min.) 160 gpm (640 L/min.)	COBA CODA COFA COHA COJA	T-163A T-11A T-2A T-17A T-19A	
3 Port	Pilot-to-Close Check Valve, 20:1 Pilot Ratio	.11 in. (2,8 mm)	CODO	T-11A	
3 Port	Pilot-to-Close Check Valve, 120:1 Pilot Ratio	.05 in. (1,27 mm)	COFO	T-2A	

Circuit Savers Overview (continued)

Function	Description	Nominal Capacity	Model	Cavity	Symbol
3 Port	Accumulator Sense, Pump Unload, Pilot Valve, 15%	46 in ³ /min. (0,75 L/min.)	QPAA	T-11A	
3 Port	Accumulator Sense, Pump Unload, Pilot Valve, 20%	46 in ³ /min. (0,75 L/min.)	QPAB	T-11A	
3 Port	Accumulator Sense, Pump Unload, Pilot Valve, 30%	46 in ³ /min. (0,75 L/min.)	QPAC	T-11A	
3 Port	Accumulator Sense, Pump Unload, Pilot Valve, 50%	46 in ³ /min. (0,75 L/min.)	QPAD	T-11A	
4 Port	Accumulator Sense, Pump Unload, Pilot Valve with Check, 15%	12 gpm (45 L/min.)	QCDA	T-21A	
4 Port	Accumulator Sense, Pump Unload, Pilot Valve with Check, 20%	15 gpm (60 L/min.)	QCDB	T-21A	

Circuit Savers Overview (continued)

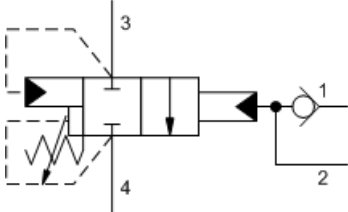
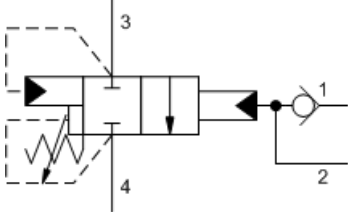
Function	Description	Nominal Capacity	Model	Cavity	Symbol
4 Port	Accumulator Sense, Pump Unload, Pilot Valve with Check, 30%	15 gpm (60 L/min.)	QCDC	T-21A	
4 Port	Accumulator Sense, Pump Unload, Pilot Valve with Check, 50%	15 gpm (60 L/min.)	QCDD	T-21A	
Adjustable Snubber	Male 1/4 NPTF to Female 1/4 NPTF (Buna)	.035 in (0,9 mm) dia.	NSAB-KXN-BA		
Adjustable Snubber	Male 1/4 NPTF to Female 1/4 NPTF (Viton)	.035 in (0,9 mm) dia.	NSAB-KXV-BA		
Adjustable Snubber	Female 1/4 NPTF to Female 1/4 NPTF (Viton)	.035 in (0,9 mm) dia.	NSAB-KXV-AA		
Adjustable Snubber	Female SAE-4 to Female SAE -4 (Buna)	.035 in (0,9 mm) dia.	NSAB-KXN-HH		
Adjustable Snubber	Female SAE-4 to Female SAE -4 (Viton)	.035 in (0,9 mm) dia.	NSAB-KXV-HH		
Adjustable Snubber	Male SAE-4 to Female SAE -4 (Buna)	.035 in (0,9 mm) dia.	NSAB-KXN-HS		
Adjustable Snubber	Male SAE-4 to Female SAE -4 (Viton)	.035 in (0,9 mm) dia.	NSAB-KXV-HS		
Adjustable Snubber	Male SAE-4 to Female 1/4 NPTF (Viton)	.035 in (0,9 mm) dia.	NSAB-KXV-AS		
Adjustable Snubber	Male 1/4 NPTF to Female 1/4 BSPP (Viton)	.035 in (0,9 mm) dia.	NSAB-KXV-TA		

Circuit Savers Overview (continued)

Function	Description	Nominal Capacity	Model	Cavity	Symbol
Adjustable Snubber	Male 1/4 BSPP to Female 1/4 BSPP (Viton)	.035 in (0,9 mm) dia.	NSAB- KXV-BT		
Adjustable Snubber	Female 1/4 BSPP to Female 1/4 BSPP (Viton)	.035 in (0,9 mm) dia.	NSAB- KXV-TT		