

Pressure Relief and Regulating Valves



APPLICATIONS

Pressure Limiting and Regulating Relief Cartridges

Sun pressure limiting and regulating relief cartridges are normally closed pressure control elements designed to maintain a constant pressure differential between port 1 (inlet) and port 2 (outlet) when oil flows through the valve. Sun Hydraulics' relief valves are all fully adjustable over a wide range of operating pressures up to and including 5000 psi (350 bar) (6000 psi [420 bar] intermittent). (Air piloted versions have lower pressure ranges). Prior to shipping, all Sun relief valves are factory pressure set with a flow of 4 gpm (16 L/min).

NOTE: All Sun two port relief cartridges (except reliefs used to control pilot flow) are functionally interchangeable (i.e. same flow path and same cavities for a given frame size.)

Direct acting pressure limiting relief valves are fast acting and should be used to:

- Protect fixed displacement pumps and directional control valves when pump output flow is intermittently blocked.
- Limit pressure overshoot associated with pressure compensated pumps.
- Protect hydraulic actuators (both cylinders and motors) from shock pressures associated with starting and stopping high inertia loads.

Pilot operated [two stage] pressure regulating relief valves have lower pressure override characteristics than direct operated valves, although they are not as fast acting. They incorporate a mechanism to protect the orifice leading to the second stage, from oil borne contamination. They should be used to:

- Maintain a constant pressure by modulating continuous, variable flow over a wide adjustment range.

With blocked center directional valves and variable displacement pumps, or open center directional valves and fixed displacement pumps where fast response, low leakage and dirt tolerance are required for shock pressure relief, consider direct acting valves.

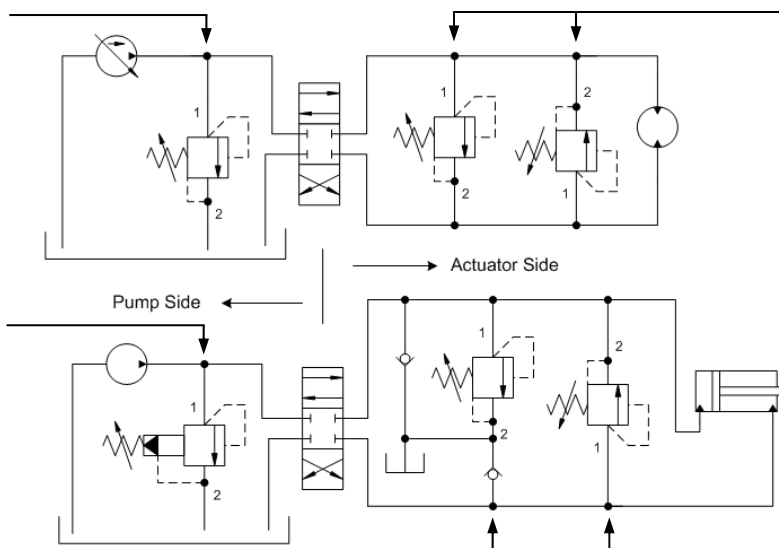

With equal or unequal displacement actuators consider:

- 1) Pilot operated valves for accurate pressure regulation
- 2) Direct acting valves for fast response, dirt tolerance and low leakage
- 3) Kick-down valves to eliminate heat generation. (Do not use in load holding applications.)

With blocked center directional valves and fixed displacement pumps where accurate pressure regulation of continuous flow is required, consider pilot operated valves.

However, with unequal displacement actuators or motors having drain ports, be careful to use relief valve circuits that avoid cavitation and/or supercharging.

This drawing is not a real circuit and is intended for description only.

DESIGN CONCEPTS AND FEATURES

Two Port Direct Acting Differential Area Pressure Limiting Relief Cartridges – RD*A

The performance parameters optimized in Sun's unique RD*A differential area relief valves are:

- Relatively flat pressure rise (especially at high end of spring range.)
- High flow capacity (25 to 200 gpm [100 to 800 L/min]) relative to physical size (comparable to piloted operated valves).
- Low hysteresis (reseats at 90% of valve setting) and very low leakage (10 drops/min at reseal).

- Utilizes a seated design which makes the valve suitable for use in load holding applications.
- Fast opening and closing (2 ms typical response time).
- Insensitivity to varying oil temperature and oil-borne contamination.
- Reliable cold oil closing and exceptional hot oil stability (no oscillation).
- Rugged, robust, construction withstands high pressure shocks or back pressure.
- Not suitable where frequent pressure adjustment is required, as they are difficult to adjust under pressure.

NOTE: See General Relief Valve Notes 1, 2, and 4 on page 5.

Two Port Pilot Operated Pressure Regulating Relief Cartridges - RP*C

Sun's RP*C balanced piston, two stage, pressure regulating cartridge valves that are optimized to maintain a constant pressure variable flow. Performance parameters include:

- Low hysteresis (+/-1%) and low spool leakage (leakage is frame size dependant and varies fro 2-5 in.³/min. per 1000 psi [32-82 cc/min per 70 bar], from port 1 to port 2 or port 2 to port 1.)
- Exceptional stability.
- Very flat pressure override curve resulting in little pressure change over a wide variation in flow.
- Easy to adjust under pressure.
- Typical response time of 10 ms.
- Can be sensitive to oil-borne contamination.

NOTE: See General Relief Valve Notes 1, 2 and 5 on page 5.

Two Port Pilot Operated Pressure Regulating Relief Cartridges – RP*S

Sun's RP*S balanced poppet, two stage, pressure regulating cartridges have similar features to the RP*C series except a poppet replaces the spool in the main stage. The modified performance parameters include:

- Slightly higher hysteresis (+/- 2%).
- Pressure override curve greater than RP*C balanced piston valve, but lower than RD*A direct acting relief.
- Seated poppet design achieves very low leakage (10 drops/min at reseal); valve is suitable for use in load holding applications.
- Exceptional stability [no oscillation].
- Poppet design almost eliminates cavitation erosion that can occur in manifolds adjacent to the valve discharge holes.

NOTE: See General Relief Valve Notes 1, 2, and 4 on page 5.

Two Port Pilot Operated Rapid Response Pressure Limiting Relief Cartridges – RP*E

Sun's RP*E fast acting two stage balanced piston relief cartridges are used to protect hydraulic components from pressure shock damage. Performance parameters include:

- Fast opening and closing (obtained by reducing internal damping and overlapping.)
- Typical response time of 2 ms.
- Response time is improved compared to a standard RP*C relief, but stability is reduced; this valve is unsuitable for use in continuous duty applications.
- Low hysteresis and low spool leakage (leakage is frame size dependant and varies from 2-5 in.³/min. per 1000 psi (32-82 cc/min per 70 bar), from port 1 to port 2 or port 2 to port 1.)
- For most rapid response applications, use Sun's RD*A

direct acting differential area relief valves. They offer less sensitivity to contaminants, have lower shut off leakage, and are more stable.

NOTE: See General Relief Valve Note 1 on page 5.

Two Port Pilot Operated Kick-Down Relief Cartridges – RQ*B

Sun's RQ*B balanced piston kick-down relief cartridges act like a circuit breaker in an electrical system; they will "self-vent" and shift completely open approximately 25 ms after the pressure setting is attained. All flow needs to stop in order to reset the valve; they are intended to be used either on the actuator side of a directional valve or after the pump in systems where it is practical to shut off the pump. Performance parameters of Sun's kickdown relief valves include:

- Accurate trigger point (valve setting).
- At nominal full flows, pressure drop is very low, reducing heat generation. (Approximately 50 psi [3,5 bar] for RQEB at 10 gpm [40 L/min].)
- Low spool leakage in closed mode (before reaching "trigger point") from port 1 to port 2 (leakage is frame size dependant and varies from 2-5 in.³/min per 1000 psi [32-82 cc/min per 70 bar], from port 1 to port 2 or port 2 to port 1.)
- Once opened, the valve can only be reset by **stopping all flow** through the valve. Reversing the directional valve or shutting off the pump will reset the valve.
- *Do not use in load holding applications.*

NOTE: See General Relief Valve Note 1 on page 4.

Two Port Air Controlled Pilot Operated Pressure Regulating Relief Cartridges - RP*D

Sun's RP*D balanced piston relief valves use compressed air over a diaphragm instead of an adjustable spring to provide remote control of the valve pressure setting. Performance parameters/features include:

- Hydraulic pressure setting is directly proportional to air pressure setting (pilot ratio is 20:1).
- Maximum operating pressure equals 2000 psi (140 bar).
- Maximum air pressure should not exceed 150 psi (10,5 bar).
- Most other performance characteristics similar to RP*C relief valves.
- May be useful as an explosion proof valve where remote pressure control is required.
- Pressure settings are insensitive to back pressure at port 2 up to 1000 psi (70 bar) maximum.

Two Port Pilot Operated Soft Start Relief Valves – RP*T

Sun's unique soft start balanced poppet, two stage, relief valves ramp pressure up from a "threshold" pressure to the maximum set pressure over a fixed time period, which is slow enough to eliminate virtually all pressure overshoot in addition to providing a repeatable pressure rise ramp. (See Figure 1) This feature

makes these valves very useful in applications where smooth acceleration is needed, especially where high inertia loads are involved. Performance parameters include:

- Valve will limit pressure rise rates to below 10,000 psi (700 bar) per second.
- The threshold pressure (valve starts to open) is generally 2400-2700 psi (168-189 bar) below maximum set pressure (pressure where valve is fully open after ramping).
- If maintained operating pressure falls somewhere between the threshold pressure and the maximum set pressure, the main stage will not open, but there will be a continuous pilot flow of 10-25 in³/min (0,16-0,41 L/min). This feature essentially keeps the valve setting at approximately 100 psi (7 bar) above the load pressure. (An analogy would be the system pressure in a load sense circuit, with the standby or pump differential pressure adding to the system pressure up to the pressure limiter setting.)
- In the pressure range between threshold and maximum setting, if the pressure rises faster than the valve setting, the valve will open to limit pressure rise rate.
- Ramp times are typically between 300-500 ms., depending on frame size.
- Because of potential pilot flow leakage when operating between the threshold pressure and the set maximum pressure, this valve is NOT suitable for load holding.
- Poppet design almost eliminates cavitation erosion that can occur in manifolds adjacent to the valve discharge holes.

NOTE: See General Relief Valve Note 1 on page 5.

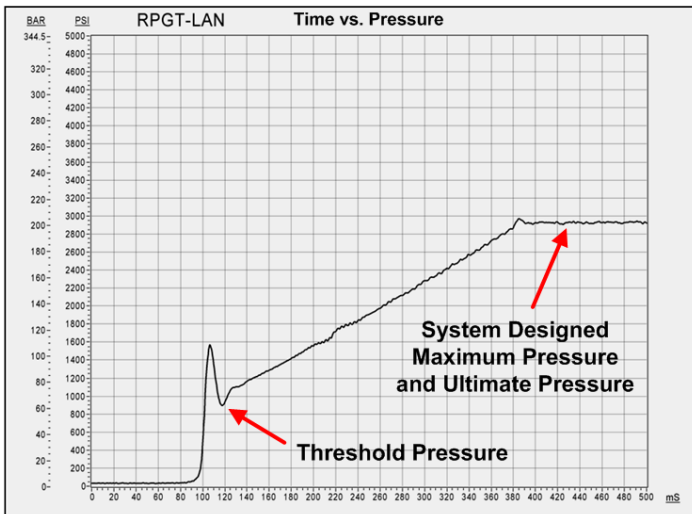

Figure 1.

Two Port Pilot Relief Cartridges, Direct Acting and Air Piloted – RBAA, RBAC, RBAD, RBAE, and (air piloted) RBAR

Sun’s pilot relief cartridges are comprised of the direct acting pilot stages of Sun’s pilot operated relief valves and are used to remotely control the pressure setting of other pilot operated valves (relief, sequence, and reducing). Performance parameters include:

- Fast opening and closing (2 ms).
- Low hysteresis.
- Low leakage (when closed) at reset (5 drops/min.)
- Requires little effort to adjust under pressure, and are available with hand knobs and panel mount options for frequent-adjust applications.
- Flow capacities: RBAC, and RBAD: .25 gpm (1 L/min), RBAA: 0.5 gpm (2 L/min), RBAE and RBAR: 2.5 gpm (10 L/min).
- Dual pilot relief cartridge, RBAD, contains a shuttle valve to allow sensing pressure from two sources with no “cross talk”.
- Because flow capacity of the RBAA, RBAC, and RBAD pilot valves is limited, these valves should only be used as remote control elements for valves or pump/motor controls which have compatible control pilot flows.
- Any pressure at port 2 (outlet) is directly additive to the pressure setting for direct acting cartridges.
- For the air piloted RBAR, back pressure at port 2 has no effect on the valve setting.

Two and Three Port Pilot and Direct Operated Sequence Cartridges – RS*C, SC*A, SC*B, SX*A, and SX*B. (Also see Tech Tips for Sequence Valves)

Sequence relief valves provide a separate drain (port 3 or vent to atmosphere) for the adjustment spring chamber.

- “Venting” port 3 to tank or atmosphere makes the relief valve settings insensitive to back pressure at port 2 (the outlet).
- With the atmospheric vent option, in addition to possible external leakage, there is the risk of contaminant intrusion, depending on the operating environment, which can result in internal corrosion and valve malfunction.
- Direct operated versions (SC*A, SC*B, SX*A and SX*B) have very low leakage and can be used in load holding applications.
- Pilot operated versions (RS*C) may be vented or “blocked”. Blocking the pilot flow at port 3 [with a two-way valve, for instance], will cause the valve to remain closed even at its set point. If port 3 is then vented, the valve will operate normally, opening at its set point.

Three Port Pilot Operated Vented Relief Cartridges – RV*A and RV*S

Sun’s RV*A balanced piston, and RV*S balanced poppet, two stage, vented, pressure regulating cartridges provide an extra remote pilot port (port 3) between the main piston and pilot. General performance characteristics are the same as RP*C balanced piston and RP*S balanced poppet two port valves described above. Other performance parameters include:

- Port 3 control pilot flow varies between 7 and 20 in.³/min (0,11-0,33 L/min), depending on frame size. To control the valve, the use of appropriately matched pilot valves in the port 3 circuit is required (Sun RBAA, RBAC, RBAD are recommended.)

- “Venting” or “blocking” the pilot flow from port 3, such as with a 2-way valve (See Figure 2), will affect the main flow from port 1 to port 2, causing the valve to either “vent” (open) or “block” (close at the main relief setting), respectively. With spring ranges of 3000 psi (210 bar) and below, and atmospheric pressure at port 3, pressure at port 1 will be 40-75 psi (2,5-5 bar) at half the valve’s rated flow.

NOTE: See General Relief Valve note 3 on Page 5.

Three Port Pilot Operated Soft Start Vented Relief Cartridges – **RV*T**

Sun’s RV*T balanced poppet, two stage, vented, soft-start pressure regulating cartridges provide a remote pilot port (port 3) between the main piston and pilot. General performance characteristics, including the extended ramp time with almost no overshoot, are the same as RP*T two port valves described prior. Other performance parameters include:

- “Venting” or “blocking” the pilot flow from port 3, such as with a 2-way valve (See Figure 2), will affect the main flow from port 1 to port 2, causing the valve to either “vent” (open) or “block” (close with a ramp to the main relief setting), respectively. With spring ranges of 3000 psi (210 bar) and below, and atmospheric pressure at port 3, pressure at port 1 will be 125-200 psi (9-14 bar) at half the valves rated flow.
- When blocking the vent port, the valve will ramp from a lower threshold pressure, less than 200 psi (14 bar), and have a ramp time of 500-700 ms.
- Port 3 control pilot flow varies between 10 and 20 in.³/min (0,16-0,33 L/min), depending on frame size.
- This valve, working in conjunction with a Sun soft-shift solenoid valve as the vent (port 3) control valve (See Figure 2), can provide an effective shock free load and unload in hydraulic systems.

RV*A/S Vented Relief (or RV*T Soft Relief)

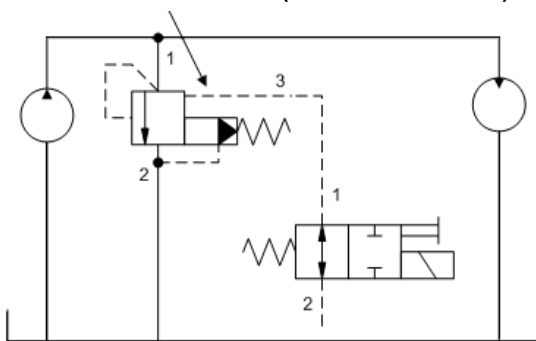

Figure 2. Pilot operated vented relief valves can be used to start and stop hydraulic motors by using a two-way valve connected to the vent port (port 3). (By using a **pilot operated vented soft relief valve**, an actuator, such as a motor connected to a conveyor drive or fan, can be “softly” ramped up to its’ operating speed with little or no shock.) *This drawing is not a real circuit and is intended for description only.*

Three Port Pilot Operated Bypass Compensator (with Relief) Cartridges – **RV*B**

Sun’s RV*B balanced piston, two stage, relief cartridges use the main section of the valve as a bypass compensator for an external fixed/variable orifice (such as a needle valve).

- Port 3 is connected to the outlet, or load side, of the orifice, and port 1 is connected to the inlet side (See Figure 3).
- The valve bypasses flow to tank (port 2) at work load pressure plus the compensator pressure drop. The resulting function is a pressure compensated bypass flow control.
- If outlet or work pressure rises to the maximum pressure setting, the valve then acts as a system relief valve.
- Pressure at port 2 (bypass) is directly additive to the maximum pressure setting sensed at port 3 (sense). Also, if pressure at port 2 exceeds work pressure (at port 3) plus bypass compensator pressure differential, pressure compensation of orifice will cease.

Sun RV*B bypass compensator with relief function

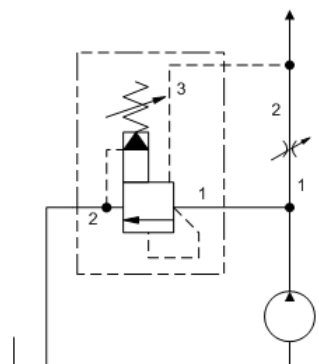

Figure 3. This drawing is not a real circuit and is intended for description only.

Four Port Pilot Operated Vented Relief Cartridges – **RV*D**

Sun’s RV*D balanced piston, two stage, vented, pressure regulating cartridges provide a drain port (port 4) in addition to the remote pilot port (port 3). General performance characteristics are identical to RV*A three port valves previously described. Other performance parameters include:

- With drain port (port 4) connected to tank, the valve is insensitive to any back pressure on port 2.
- Can be used as a dual pressure sequence valve by connecting the vent port (port 3) to a remote, selectable, pilot source.
- Any pressure at the drain port (port 4), is directly additive to pressure setting at the inlet (port 1).

NOTE: See General Relief Valve note 3 on page 5.

General Relief Valve Notes:

- 1) Any pressure at port 2 (outlet) is directly additive to the pressure setting at port 1 (inlet).
- 2) If absolute system pressure must be regulated when variable back pressure is present at port 2, consider using either Sun's RS*C, SC*A, SC*B, SX*A, or SX*B 2 and 3-port sequence valves, (The SC*A and SC*B valves incorporate a reverse flow check) or Sun's RV*D 4-port ventable relief valve with an external drain.
- 3) The main relief pressure setting of vented relief valves must always be higher than that of the remote pilot relief valve.
- 4) In lower pressure circuits, pressure drop through the cartridge, manifold, and plumbing must be considered

Which Relief Valve should I choose?

In order to help with deciding which type of relief is the right choice for a typical application, the table below represents a short review of the features and benefits of the most popular relief designs described previously. (Key advantages for each type are shown in bold.)

Direct Acting Relief Valves Differential Area Type	Pilot Operated Relief Valves	
	Sliding Spool Type	Balanced Poppet Type
Fast response (2 ms)	Medium response (10 ms)	Medium response (7 ms)
Low hysteresis (8-10%)	Lowest hysteresis (1%)	Low hysteresis (2-3%)
Dirt tolerant	Can be contaminant sensitive	Dirt tolerant
Low over/under shoot	Potential for higher over/under shoot	Potential for higher over/under shoot
Moderate pressure override	Low pressure override	Slightly higher pressure override
Low leakage (10 drops/min)	Some internal leakage (2-5 in. ³ /min.)	Low leakage (10 drops/min)
Difficult to adjust under pressure	Easy to adjust under pressure	Easy to adjust under pressure

Relief Valve Overview

Relief Cartridges					
Function	Description	Nominal Capacity	Model	Cavity	Symbol
2 Port	Direct Acting	12 gpm (45 L/min.) 25 gpm (95 L/min.) 50 gpm (200 L/min.) 100 gpm (380 L/min.) 200 gpm (760 L/min.)	RDBA RDDA RDFA RDHA RDJA	T-162A T-10A T-3A T-16A T-18A	
2 Port	Pilot Operated, Balanced Piston	12 gpm (45 L/min.) 25 gpm (95 L/min.) 50 gpm (200 L/min.) 100 gpm (380 L/min.) 200 gpm (760 L/min.)	RPCC RPEC RPGC RPIC RPKC	T-162A T-10A T-3A T-16A T-18A	
2 Port	Pilot Operated, Balanced Poppet	50 gpm (200 L/min.) 100 gpm (380 L/min.) 200 gpm (760 L/min.)	RPGS RPIS RPKS	T-3A T-16A T-18A	
2 Port	Pilot Operated, Balanced Piston, Fast Acting	25 gpm (95 L/min.) 50 gpm (200 L/min.) 100 gpm (380 L/min.) 200 gpm (760 L/min.)	RPEE RPGE RPIE RPKE	T-10A T-3A T-16A T-18A	
2 Port	Kick-Down	12 gpm (45 L/min.) 25 gpm (95 L/min.) 50 gpm (200 L/min.) 100 gpm (380 L/min.) 200 gpm (760 L/min.)	RQCB RQEB RQGB RQIB RQKB	T-162A T-10A T-3A T-16A T-18A	
2 Port	Pilot Operated, Balanced Piston, Air Controlled	50 gpm (200 L/min.) 100 gpm (380 L/min.) 200 gpm (760 L/min.)	RPGD RPID RPKD	T-3A T-16A T-18A	

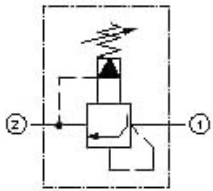
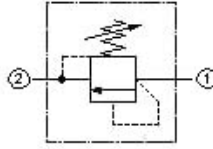
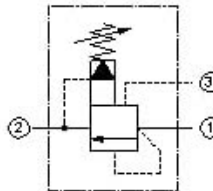
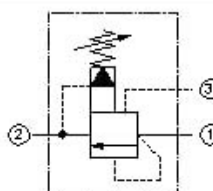
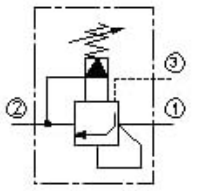
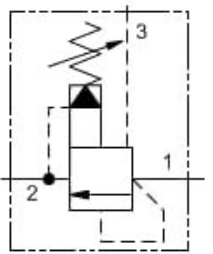
Relief Cartridges					
Function	Description	Nominal Capacity	Model	Cavity	Symbol
2 Port	Pilot Operated, Balanced Poppet, Soft	25 gpm (95 L/min.) 50 gpm (200 L/min.) 100 gpm (380 L/min.) 200 gpm (760 L/min.)	RPET RPGT RPIT RPKT	T-10A T-3A T-16A T-18A	
2 Port	Pilot Relief Valve	.5 gpm (2 L/min.) .25 gpm (1 L/min.) 2.5 gpm (10 L/min.)	RBAA RBAC RBAE	T-3A T-10A T-8A	
3 Port	Pilot Operated, Balanced Piston, Ventable	7.5 gpm (30 L/min.) 15 gpm (60 L/min.) 30 gpm (120 L/min.) 60 gpm (240 L/min.) 120 gpm (480 L/min.)	RVBA RVCA RVEA RVGA RVIA	T-163A T-11A T-2A T-17A T-19A	
3 Port	Pilot Operated, Balanced Poppet, Ventable	15 gpm (60 L/min.) 25 gpm (95 L/min.) 50 gpm (200 L/min.) 120 gpm (480 L/min.)	RVCS RVES RVGS RVIS	T-11A T-2A T-17A T-19A	
3 Port	Pilot Operated, Balanced Poppet, Ventable, Soft	30 gpm (120 L/min.) 60 gpm (240 L/min.)	RVET RVGT	T-2A T-17A	
3 Port	Bypass Compensator, With Relief Function	2.5 gpm (10 L/min.) 5 gpm (20 L/min.) 10 gpm (40 L/min.) 20 gpm (80 L/min.) 40 gpm (160 L/min.)	RVBB RVCB RVEB RVGB RVIB	T-163A T-11A T-2A T-17A T-19A	
4 Port	Pilot Operated, Balanced Piston, Ventable With External Drain	15 gpm (60 L/min.) 30 gpm (120 L/min.) 60 gpm (240 L/min.) 120 gpm (480 L/min.)	RVCD RVED RVGD RVID	T-21A T-22A T-23A T-24A	