

Fixed Setting, 4.5:1 Pilot Ratio, Counterbalance Valve

0-15 gpm (0-60 L/min)

CBCG-XM*

Product Description

Fixed setting, 3-port counterbalance valves function similarly to the adjustable versions except the fixed setting is pre-set to a nominal value. These valves incorporate a free flow check allowing flow from port 2 to port 1 and a direct acting, pilot assist relief that controls flow from port 1 to port 2. Back pressure at port 2 is additive to the valve setting by a factor of one plus the pilot ratio.

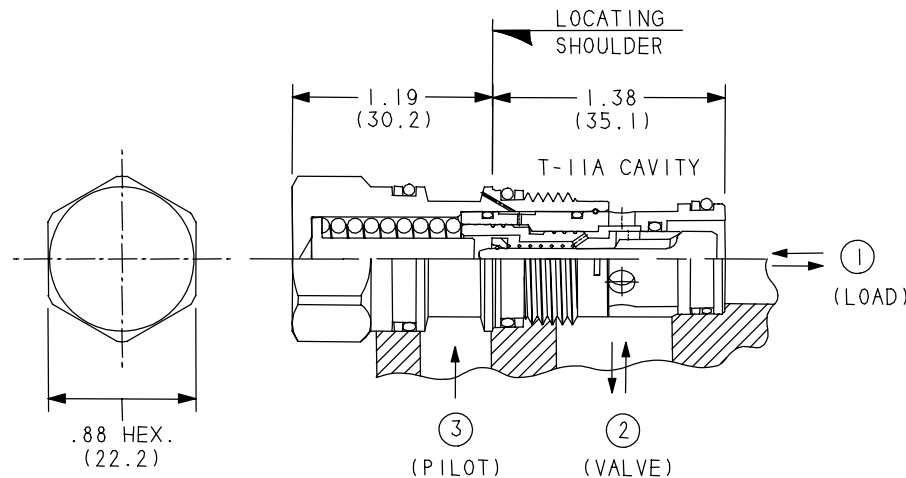
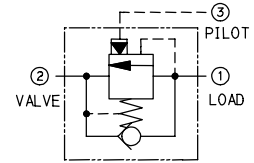

in (mm)

Technical Features

- All 3-port counterbalance and pilot-to-open check cartridges are physically interchangeable (i.e. same flow path, same cavity for a given frame size).
- Fixed setting counterbalance valves offer a shorter cartridge extension than the adjustable version.
- Incorporates the Sun floating style construction to eliminate the effects of internal parts binding due to excessive installation torque and/or cavity/cartridge machining variations.
- Provides both overpressure and thermal relief protection, and features a sealed pilot piston, thereby preventing leakage between ports 2 and 3.
- The fixed setting counterbalance valve can be used to protect cylinder seals in outrigger circuits from damage due to thermal expansion, however, they should not be applied in circuits in which a matched valve setting may be required such as dual cylinder applications.
- Nominal valve setting of 5350 psi (370 bar) provides load holding up to 3760 psi (260 bar).
- **Note:** The percentage difference between the cracking and reseal values for the fixed and adjustable versions are identical. However, the cracking point for the adjustable control can be set via the adjustment mechanism to within ± 50 psi (3.5 bar) of the specified value. In the case of the fixed setting version, the setting tolerance can only be maintained within a ± 350 psi (20 bar) range. Thus for the fixed setting model, the valve will open below 5700 psi (395 bar) and will reseal above 4250 psi (295 bar).

Fixed Setting, 4.5:1 Pilot Ratio, Counterbalance Valve

Technical Data	U.S. Units	Metric Units
Capacity	15 gpm	60 L/min
Cavity	T-11A	T-11A
Pilot Ratio (nominal)	4.5:1	4.5:1
Gain Characteristic	Standard	Standard
Pilot Arrangement	Standard	Standard
Nominal Relief Setting	5350 psi	370 bar
Load Holding up to:	3760 psi	260 bar
Check Cracking Pressure	25 psi	1,8 bar
Maximum Valve Leakage (Less than) at reseal	5 drops/min	5 drops/min
Factory Pressure Setting Established at:	2 in ³ /min	32 cc/min
Valve Installation Torque	30-35 lb-ft	45-50 Nm
Valve Hex Size	7/8 in	23 mm
Buna Seal Kit Part No.	990-011-007	990-011-007
Viton Seal Kit Part No.	990-011-006	990-011-006
Cartridge Weight	0.33 lbs	0,15 kg

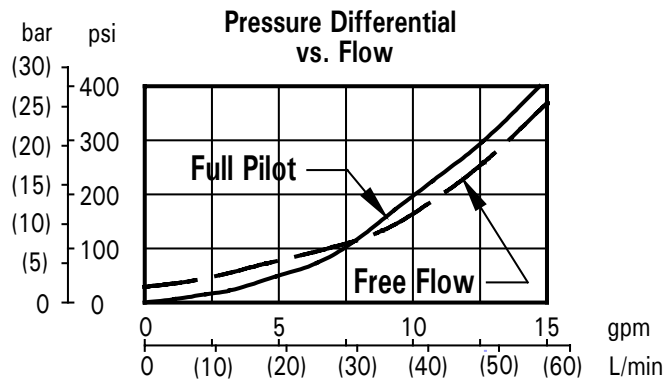

Option Selection

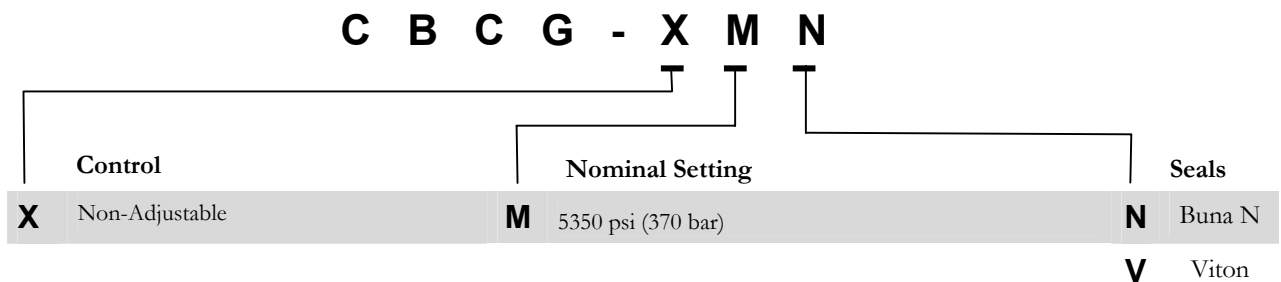

Under "Option Selection", shaded areas depict **PREFERRED** Options and non-shaded areas depict **NON-PREFERRED** Options.