

Flow Control Valves

	<i>Cartridge Type</i>	<i>Page</i>
	Fully Adjustable Needle	66
	Fully Adjustable Needle, High Capacity	67
	Fully Adjustable Needle with Reverse Flow Check	68
	Fixed Orifice, Pressure Compensated	69
	Fixed Orifice, Pressure Compensated with Reverse Flow Check	70
	Fully Adjustable Pressure Compensated with Reverse Flow Check	71
	Free Flow Side-to-Nose with Bypass Orifice	72
	Electro-proportional, Normally Closed Throttle	73
	Electro-proportional, Normally Open Throttle	74

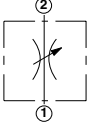

FULLY ADJUSTABLE NEEDLE

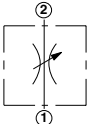
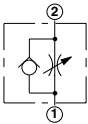
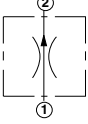
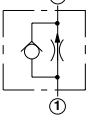
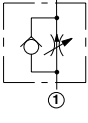
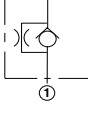
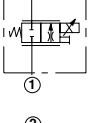
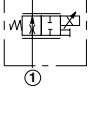
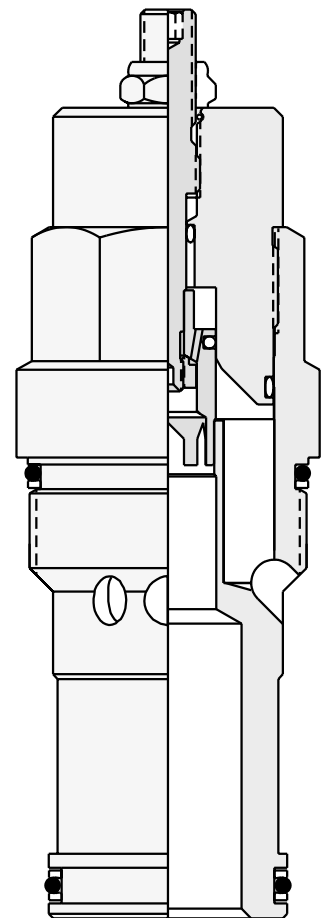
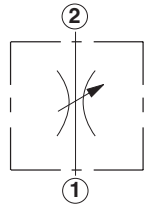
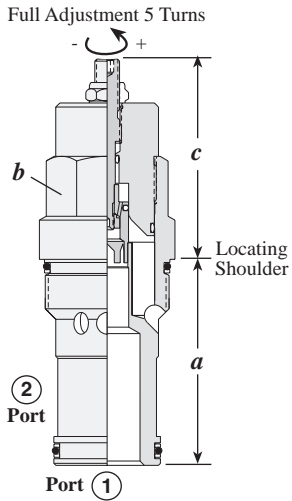

Maximum Nominal Orifice	Typical Cartridge Model Code	Cavity	Cartridge Dimensions					Installation Torque lb. ft.
			a	b	c			
					L	H	K	
.16" dia.	NFBC – LCN	T - 162A	1.22	3/4"	1.59	-	1.73	25/30
.19" dia.	NFCC – LCN	T - 13A	1.38	7/8"	2.27	2.49	2.50	30/35
.25" dia.	NFDC – LAN	T - 5A	1.62	1 1/8"	2.35	2.82	2.73	45/50
.38" dia.	NFEC – LEN	T - 16A	2.44	1 1/4"	2.66	3.06	2.91	150/160
.56" dia.	NFFC – LGN	T - 18A	3.13	1 5/8"	3.31	3.50	3.47	350/375

Performance Curves

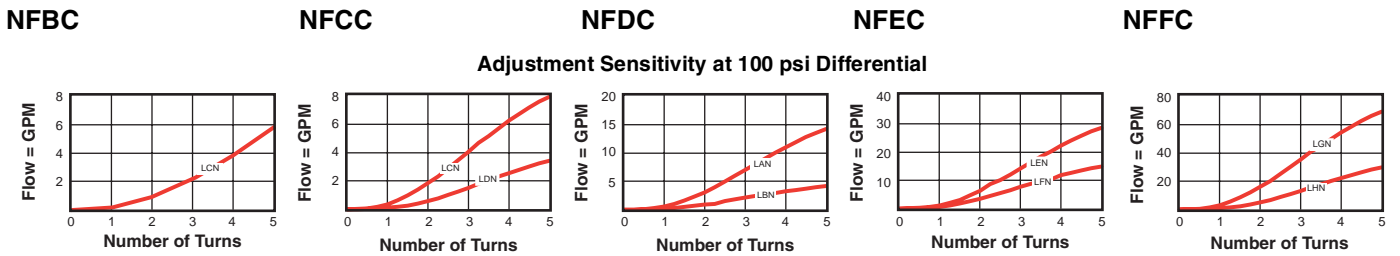

- Maximum operating pressure = 5000 psi
- Maximum valve leakage at shutoff = less than 5 drops/min.

NF ★ C – ★ ★ ★

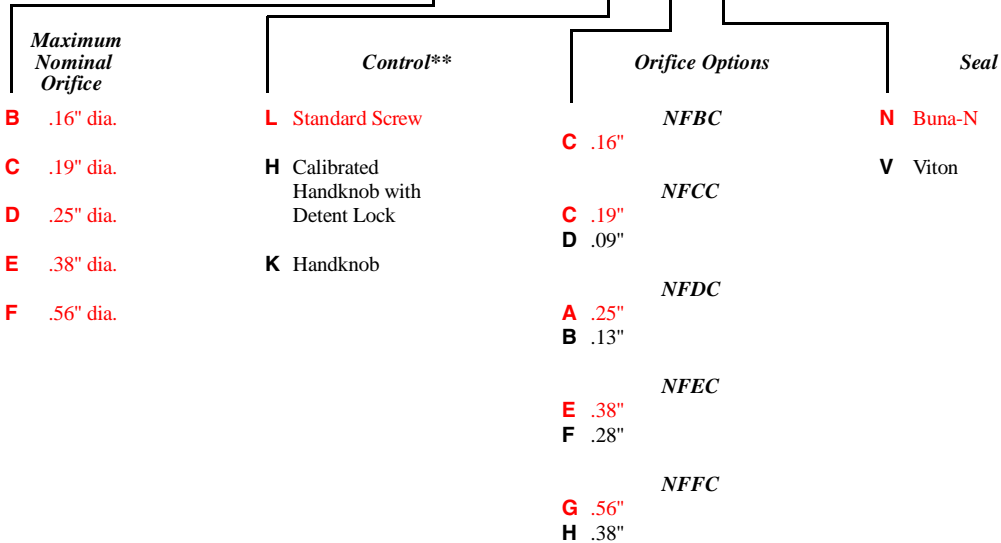

** See page 162 for information on Control Options

FULLY ADJUSTABLE NEEDLE, HIGH CAPACITY

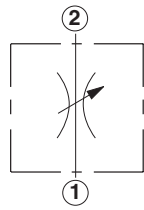
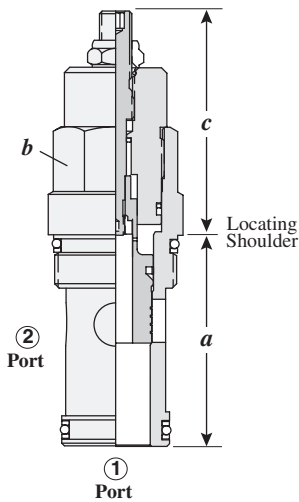

Nominal Orifice	Typical Cartridge Model Code	Cavity	Cartridge Dimensions					Installation Torque (lb. ft.)
			a	b	L	H	K	
.33" dia.	NFCD – LFN	T - 13A	1.38	7/8"	2.27	2.49	2.50	30/35
.50" dia.	NFDD – LGN	T - 5A	1.62	1 1/8"	2.35	2.82	2.73	45/50
.69" dia.	NFED – LHN	T - 16A	2.44	1 1/4"	2.66	3.06	2.91	150/160
.85" dia.	NFFD – LIN	T - 18A	3.13	1 5/8"	3.31	3.50	3.47	350/375

Performance Curves

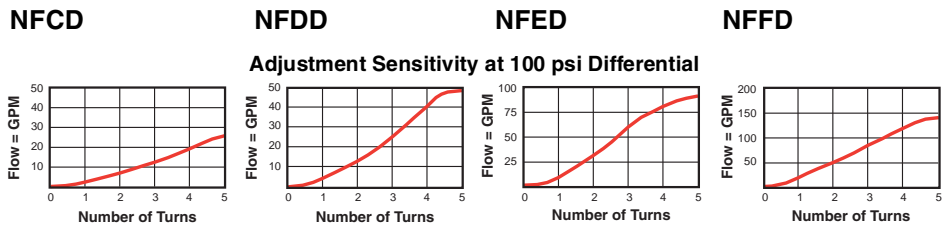

- Maximum operating pressure = 5000 psi
- Maximum valve leakage at shutoff = less than 5 drops/min.

NF * D - * * *

Nominal Orifice	Control**	Orifice Options	Seal
C .33" dia.	L Standard Screw	F .33" NFCD	N Buna-N
D .50" dia.	H Calibrated Handknob with Detent Lock	G .50" NFDD	V Viton
E .69" dia.		H .69" NFED	
F .85" dia.	K Handknob	I .85" NFFD	

** See page 162 for information on Control Options



FULLY ADJUSTABLE NEEDLE WITH REVERSE FLOW CHECK

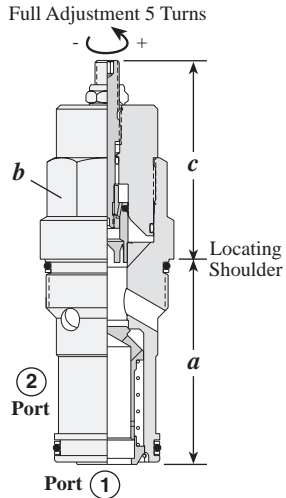

Maximum Nomininal Orifice	Typical Cartridge Model Code	Cavity	Cartridge Dimensions						Installation Torque (lb. ft.)
			a	b	c				
					L	H	K		
.16" dia.	NCBB - LCN	T - 162A	1.22	3/4"	1.59	-	1.73	25/30	
.19" dia.	NCCB - LCN	T - 13A	1.38	7/8"	2.27	2.49	2.50	30/35	
.25" dia.	NCEB - LCN	T - 5A	1.62	1 1/8"	2.35	2.82	2.73	45/50	
.38" dia.	NCFB - LCN	T - 16A	2.44	1 1/4"	2.66	3.06	2.91	150/160	
.56" dia.	NCGB - LCN	T - 18A	3.13	1 5/8"	3.31	3.50	3.47	350/375	

Performance Curves

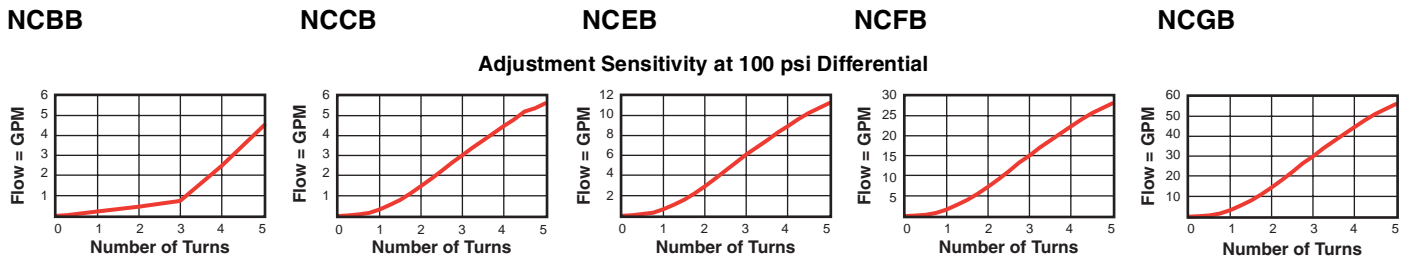

- Maximum operating pressure = 5000 psi
- Maximum valve leakage = 5 drops/min.

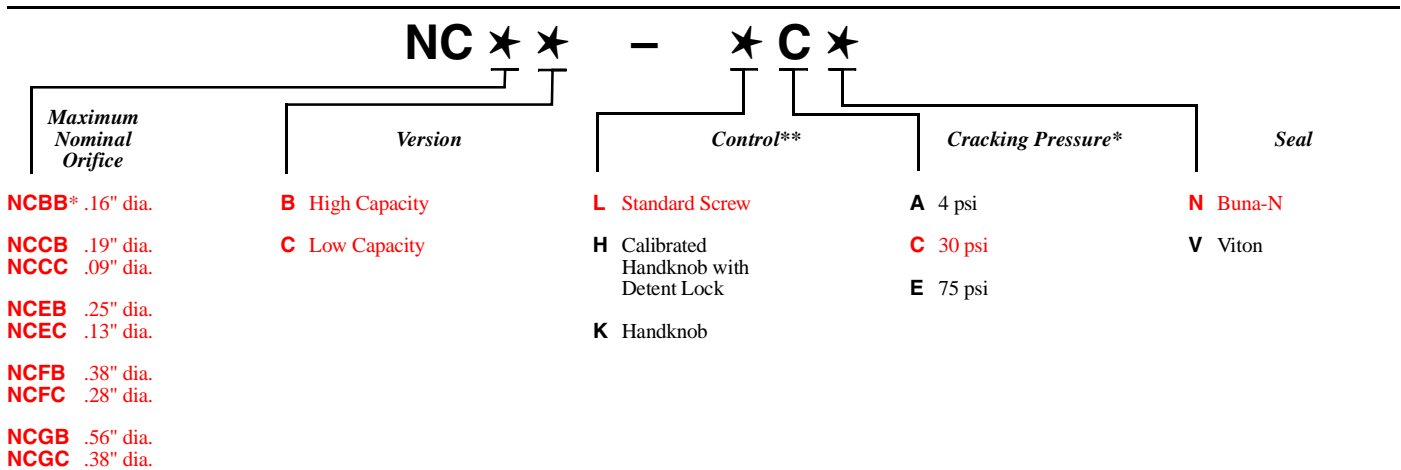

** See page 162 for information on Control Options

*Cracking Pressure Ranges: A and E ranges are not available in T-162A cavity.

FIXED ORIFICE, PRESSURE COMPENSATED

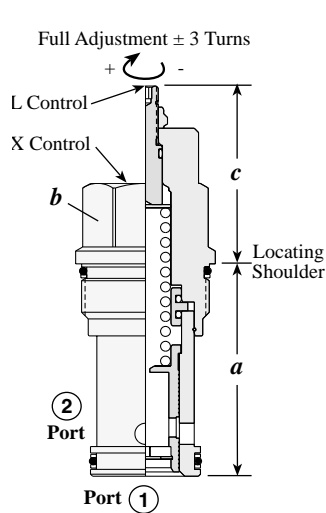

Nominal Capacity	Typical Cartridge Model Code	Cavity	Cartridge Dimensions					Installation Torque (lb. ft.)
			a	b	X	L	K	
.1-3 GPM	FXBA - XAN	T - 162A	1.22	3/4"	.82	2.11	2.55	25/30
.1-6.0 GPM	FXCA - XAN	T - 13A	1.38	7/8"	.75	2.00	2.25	30/35
.1-12.0 GPM	FXDA - XAN	T - 5A	1.62	1 1/8"	.69	2.12	2.38	45/50
.2-25 GPM	FXEA - XAN	T - 16A	2.44	1 1/4"	.97	2.44	2.69	150/160
.2-50 GPM	FXFA - XAN	T - 18A	3.13	1 5/8"	1.19	2.81	3.06	350/375

Performance Curves

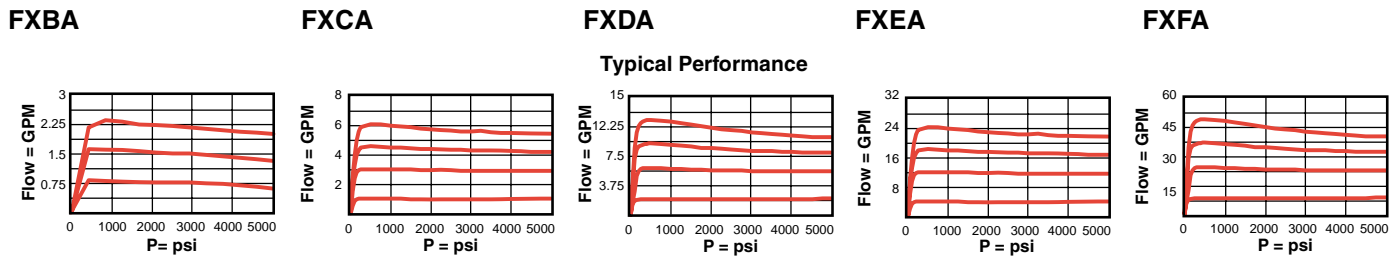

- Maximum operating pressure = 5000 psi
- Customer must specify flow setting
- Accurate pressure compensated control requires that a 200 psi minimum pressure differential be maintained across the valve.
- The tuneable control option provides +/- 25% variation from the nominal factory pre-set flow.

FX * A - * A *

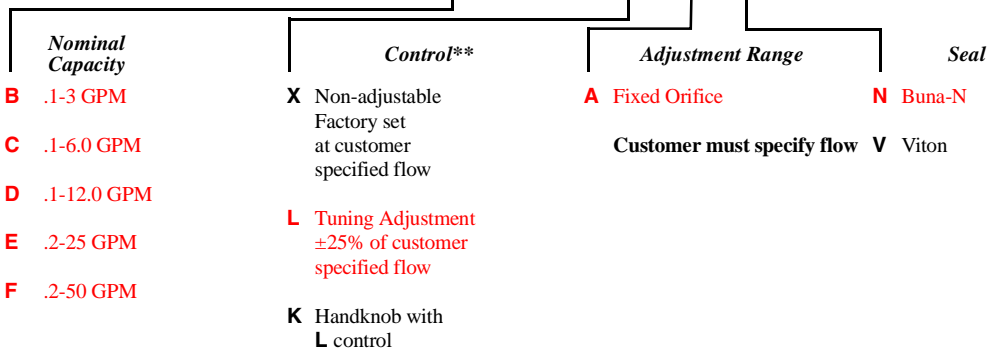

** See page 162 for information on Control Options

FIXED ORIFICE, PRESSURE COMPENSATED WITH REVERSE FLOW CHECK

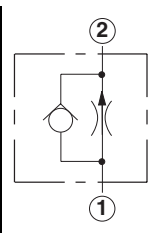
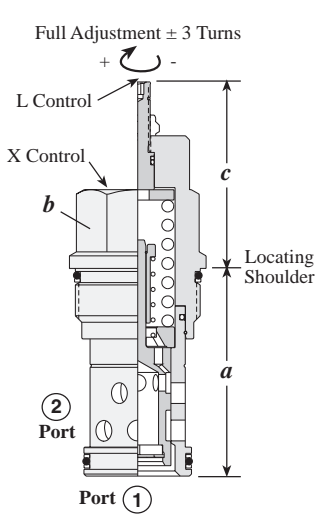

Nominal Capacity	Typical Cartridge Model Code	Cavity	Cartridge Dimensions					Installation Torque (lb. ft.)
			a	b	X	L	K	
.1-3 GPM	FCBB - XAN	T - 162A	1.22	3/4"	.82	2.11	2.55	25/30
.1-6.0 GPM	FCCB - XAN	T - 13A	1.38	7/8"	.75	2.00	2.25	30/35
.1-12.0 GPM	FCDB - XAN	T - 5A	1.62	1 1/8"	.69	2.12	2.38	45/50
.2-25 GPM	FCEB - XAN	T - 16A	2.44	1 1/4"	.97	2.44	2.69	150/160
.2-50 GPM	FCFB - XAN	T - 18A	3.13	1 5/8"	1.19	2.81	3.06	350/375

Performance Curves

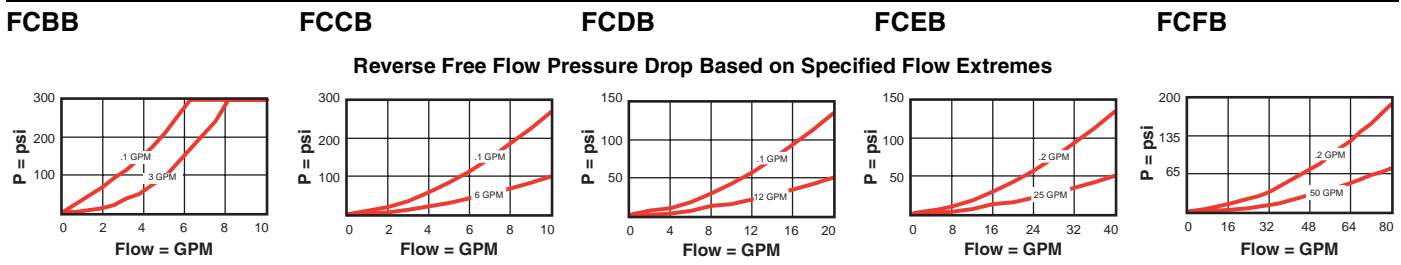

- Maximum operating pressure = 5000 psi
- Customer must specify flow setting
- Accurate pressure compensated control requires that a 200 psi minimum pressure differential be maintained across the valve.
- The tuneable control option provides +/- 25% variation from the nominal factory pre-set flow.

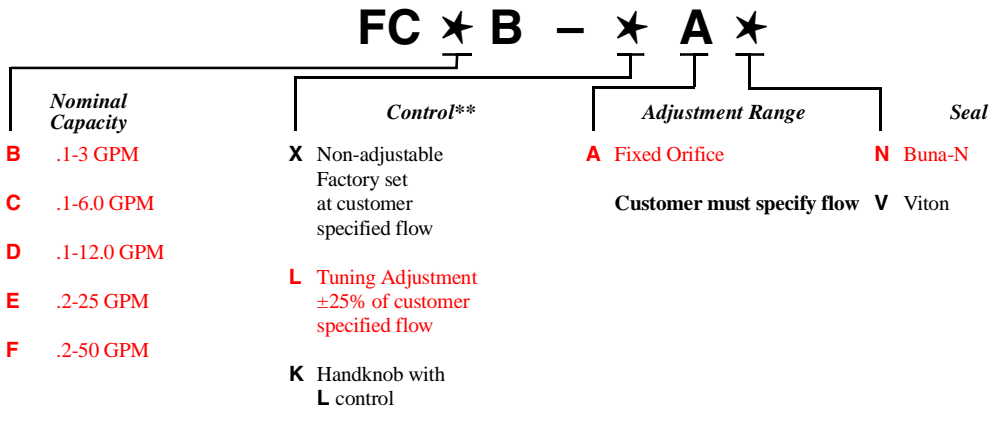

** See page 162 for information on Control Options

FULLY ADJUSTABLE, PRESSURE COMPENSATED WITH REVERSE FLOW CHECK

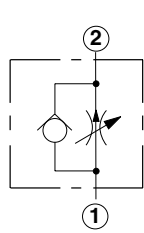
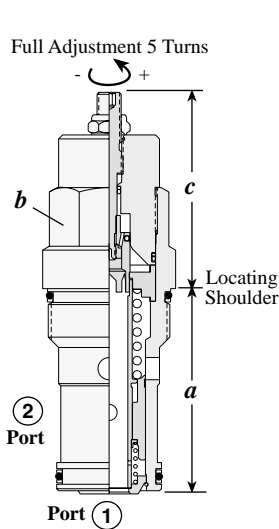

Nominal Flow Range	Typical Cartridge Model Code	Cavity	Cartridge Dimensions					Installation Torque (lb. ft.)
			a	b	c			
					L	H	K	
.1-6 GPM	FD BA - LAN	T - 13A	1.38	7/8"	2.27	2.44	2.31	30/35
.1-12 GPM	FD CB - LAN	T - 5A	1.62	1 1/8"	2.35	2.82	2.73	45/50
.2-25 GPM	FD EA - LAN	T - 16A	2.44	1 1/4"	2.66	3.06	2.91	150/160
.2-50 GPM	FD FA - LAN	T - 18A	3.13	1 5/8"	3.31	3.50	3.47	350/375

Performance Curves

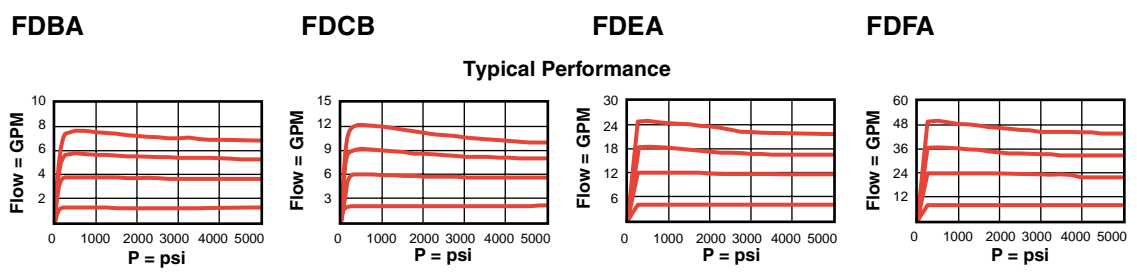

- Maximum operating pressure = 5000 psi
- Accurate pressure compensated control requires that a 200 psi minimum pressure differential be maintained across the valve.

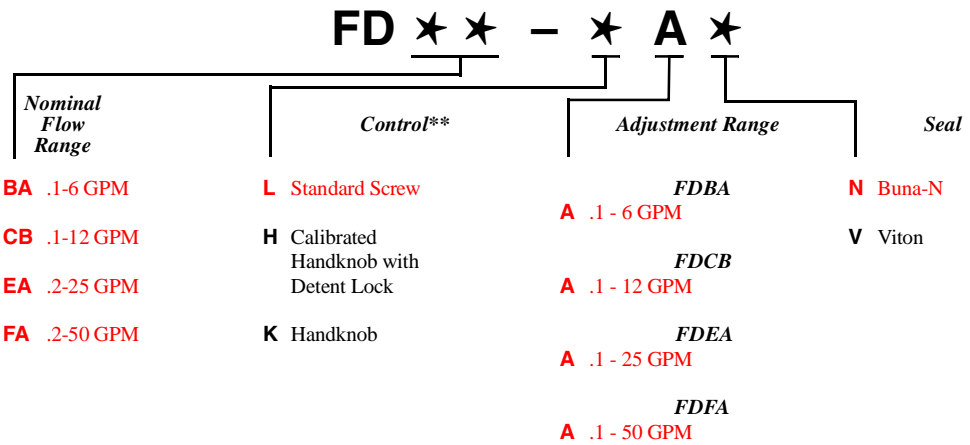

** See page 162 for information on Control Options

Visit www.sunhydraulics.com for detailed and complete technical information on our full line of products.



FREE FLOW SIDE-TO-NOSE WITH BYPASS ORIFICE

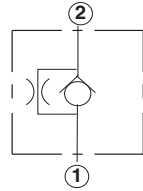
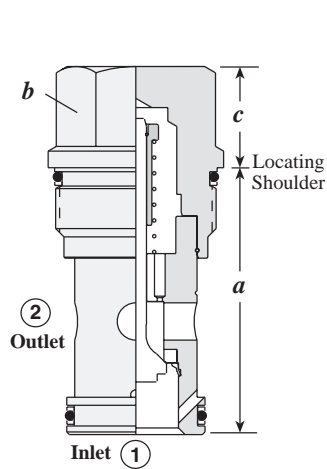

Nominal Capacity	Typical Cartridge Model Code	Cavity	Cartridge Dimensions			Installation Torque lb. ft.
			a	b	c X	
7.5 GPM	CNAC – XCN	T - 162A	1.22	3/4"	.82	25/30
15 GPM	CNCC – XCN	T - 13A	1.38	7/8"	.75	30/35
120 GPM	CNEC – XCN	T - 5A	1.62	1 1/8"	.69	45/50
60 GPM	CNGC – XCN	T - 16A	2.44	1 1/4"	.97	150/160
120 GPM	CNIC – XCN	T - 18A	3.13	1 5/8"	1.19	350/375

Performance Curves

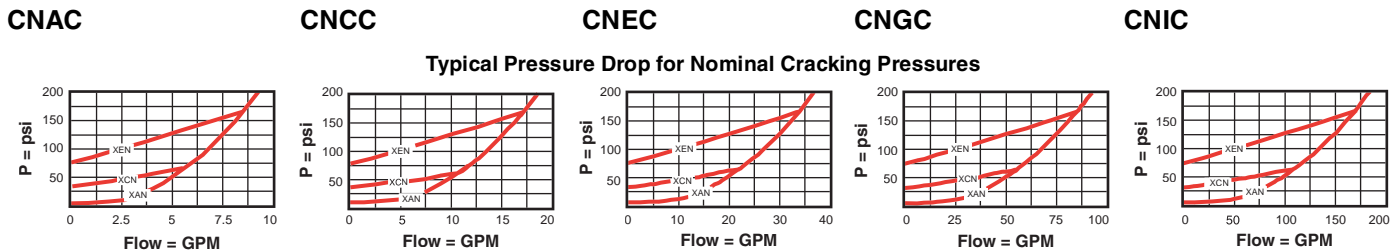

- Maximum operating pressure = 5000 psi
- Will accept 5000 psi at ports 1 and 2.
- * Orifice range = CNAC, CNCC: .015 - .062 in., CNEC: .015 - .078 in., CNGC: .015 - .094 in., CNIC: .015 - .125 in.

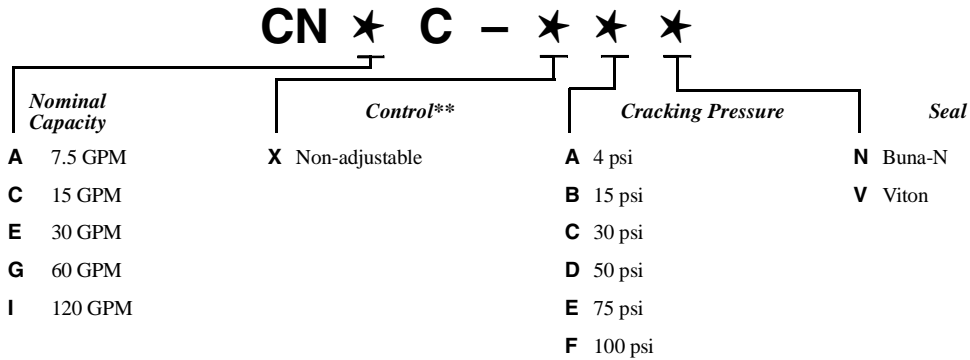

* Customer specified orifice setting range:

- CNAC: .015 - .062 in.
- CNCC: .015 - .062 in.
- CNEC: .015 - .078 in.
- CNGC: .015 - .094 in.
- CNIC: .015 - .125 in.

** See page 162 for information on Control Options

ELECTRO-PROPORTIONAL, NORMALLY CLOSED THROTTLE

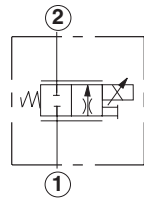
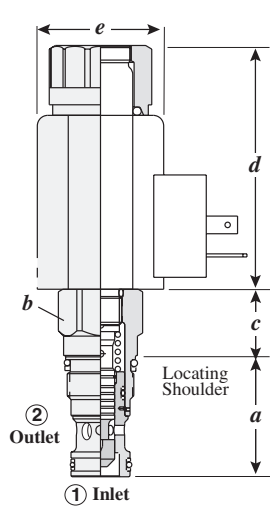

Maximum Nominal Capacity	Typical Cartridge Model Code	Cavity	Cartridge Dimensions					Installation Torque lb. ft.
			a	b	c	d	e	
7 GPM	FPCC – MCN	T - 13A	1.38	7/8"	.75	2.76	1.47	30/35

Performance Curves

FPCC

Flow vs. Command at 200 psi Differential

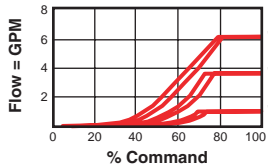

Spool A

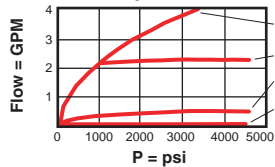

Flow vs. Pressure Differential Spool B

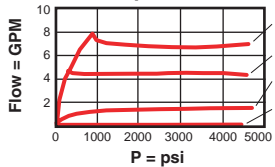

Spool C

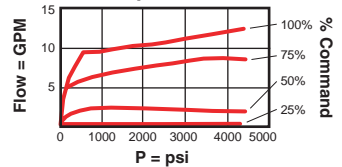

- Maximum operating pressure = 5000 psi
- Maximum valve leakage = 6 in³/min. at 3000 psi
- For optimum performance, an amplifier with current sensing and adjustable dither should be used. Dither should be adjustable between 100 - 250 Hz.

FPCC - * * *

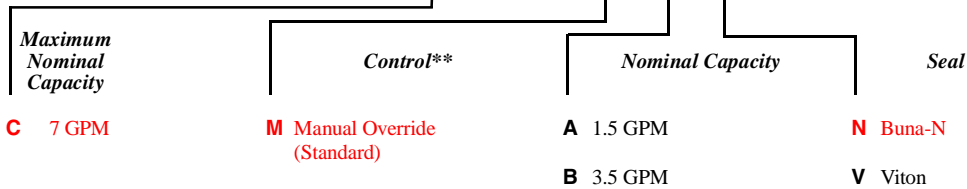

NOTE: Coil must be ordered separately. Use 12V DC or 24V DC (Series 770-***) coils only. See page 167.

** See page 162 for information on Control Options



ELECTRO-PROPORTIONAL, NORMALLY OPEN THROTTLE

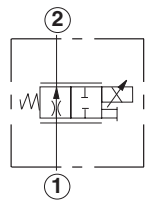
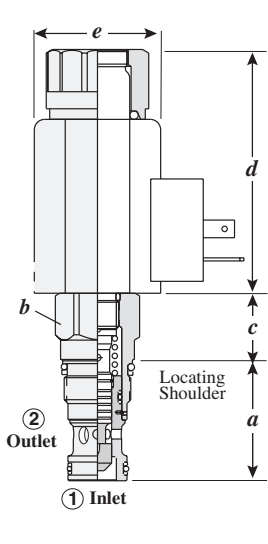

Maximum Nominal Capacity	Typical Cartridge Model Code	Cavity	Cartridge Dimensions					Installation Torque lb. ft.
			a	b	c	d	e	
7 GPM	FPCH - MCN	T - 13A	1.38	7/8"	.75	2.76	1.47	30/35

Performance Curves

FPCH

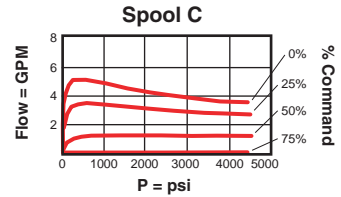
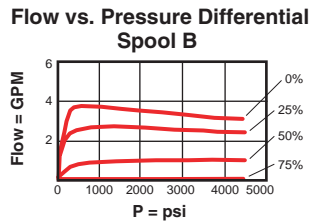
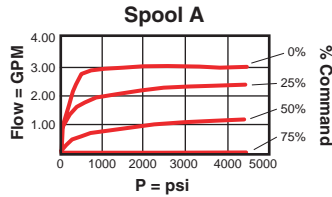
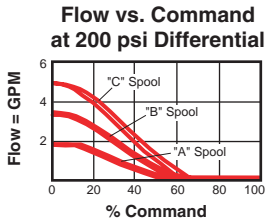

- Maximum operating pressure = 5000 psi
- Maximum valve leakage = 6 in³/min. at 3000 psi
- For optimum performance, an amplifier with current sensing and adjustable dither should be used. Dither should be adjustable between 100 - 250 Hz.

FPCH - ***

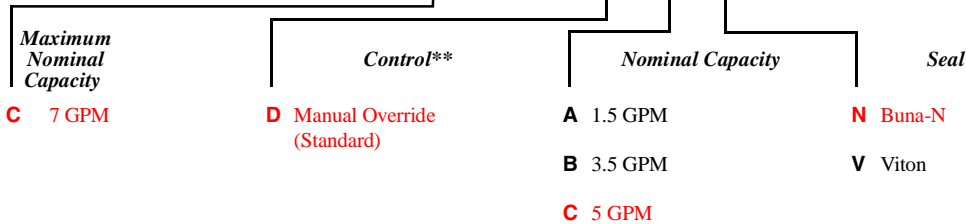

** See page 162 for information on Control Options