



BAR MANIFOLDS



- Aluminium rated to 210 bar and SG Iron rated to 350 bar.
- See page viii for ordering cartridge/body and seals. Pressure ratings, material specifications on page xiv.

Some of the bar manifolds offered in this catalogue are manufactured by Daman Products Company, Inc. All bar manifolds are parallel circuit type and contain a cavity for a Sun relief valve, pressure to tank, as well as a gauge port. Mounting kits for all bar manifolds must be ordered separately and contain brackets, bolts and washers. Metric mounting kits are also available.

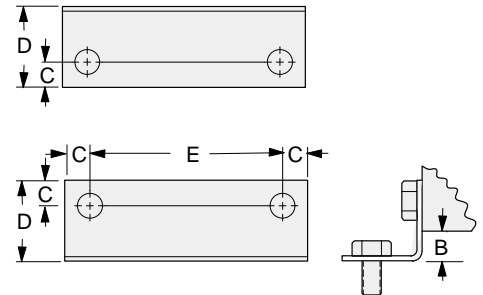

Manifold Interface	Thread Size	Mounting Bracket Dimensions				Bracket	Bolts	Washer	Model Code
		B	C	D	E				
ISO 03	.312-18UNC x .62 lg.	9,4	7,9	25,4	60,5	700-020	300-005-001	Washer Head	991-021-001
ISO 03	M8 x 1.25 x 16,0 mm lg.	9,4	7,9	25,4	60,5	700-020	300-006-001	450-002-001	991-021-002
ISO 05	.312-18UNC x .62 lg.	9,4	7,9	25,4	60,5	700-020	300-005-001	Washer Head	991-021-003
ISO 05	M8 x 1.25 x 16,0 mm lg.	9,4	7,9	25,4	60,5	700-020	300-006-001	450-002-001	991-021-004
ISO 05 y	.375-16UNC x .75 lg.	14,2	11,2	35,1	104,9	700-021	300-005-002	450-001-002	991-021-005
ISO 05 y	M10 x 1.5 x 20,0 mm lg.	14,2	11,2	35,1	104,9	700-021	300-006-002	450-002-002	991-021-006
ISO 07	.375-16UNC x .75 lg.	14,2	11,2	35,1	104,9	700-021	300-005-002	450-001-002	991-021-007
ISO 07	M10 x 1.5 x 20,0 mm lg.	14,2	11,2	35,1	104,9	700-021	300-006-002	450-002-002	991-021-008
ISO 08	.500-13UNC x 1.0 lg.	14,2	14,2	41,4	124,0	700-022	300-005-003	450-001-003	991-021-009
ISO 08	M12 x 1.75 x 25,0 mm lg.	14,2	14,2	41,4	124,0	700-022	300-006-003	450-002-003	991-021-010

ISO 03 Parallel Circuit with Relief Cavity

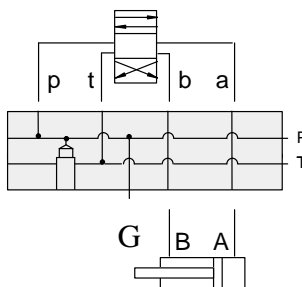

FUNCTION

One Station

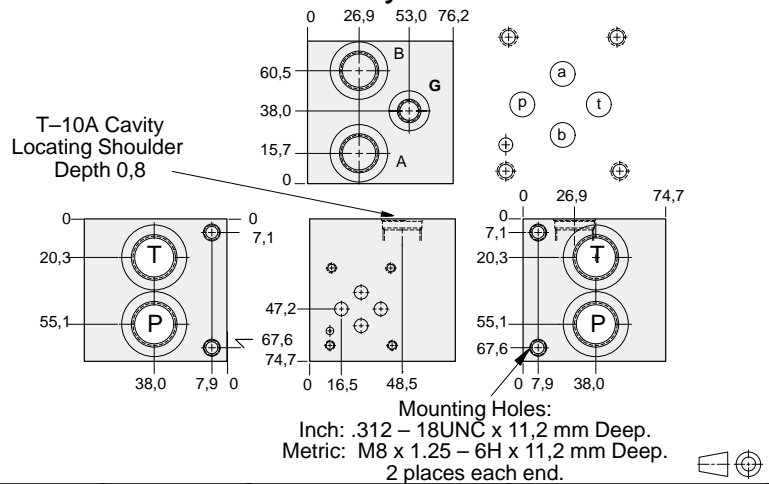

Mounting Holes	Ports P, T	Ports A, B	Gauge Port	ALUMINIUM		SG IRON	
				Model Code	List Price	Model Code	List Price
inch	.50 NPTF	.375 NPTF	.25 NPTF	VSA		VSA/S	
inch	SAE-10	SAE-8	SAE-4	VSL		VSL/S	
metric	.50 BSPP	.375 BSPP	.25 BSPP	VPA		VPA/S	

Bar Manifold Mounting Kits to be ordered separately. See page 12.087.

TYPICAL CARTRIDGES USED WITH BODIES SHOWN ABOVE

	Pilot Operated Relief Valve		Direct Acting Relief Valve
	RPEC Page 1.06		RDDA Page 1.10
OTHER VALVES:			



BAR MANIFOLDS



- Aluminium rated to 210 bar and SG Iron rated to 350 bar.
- See page viii for ordering cartridge/body and seals. Pressure ratings, material specifications on page xiv.

ISO 03 Parallel Circuit with Relief Cavity

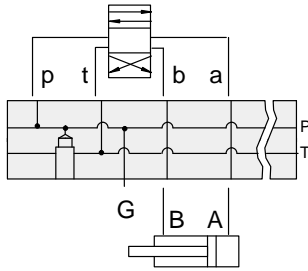

FUNCTION

Two Station

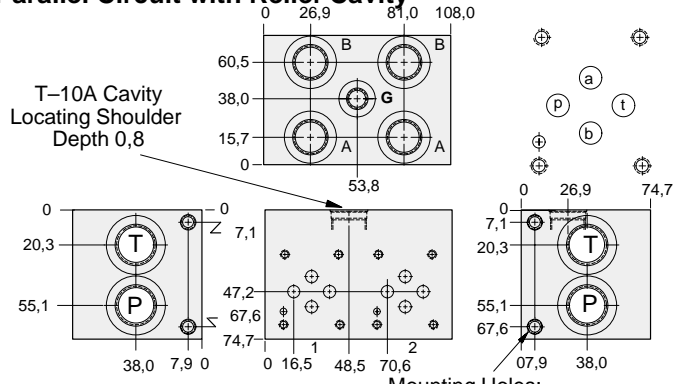

Mounting Holes:
 Inch: .312 – 18UNC x 11,2 mm Deep.
 Metric: M8 x 1.25 – 6H x 11,2 mm Deep.
 2 places each end.

Mounting Holes	Ports P, T	Ports A, B	Gauge Port	ALUMINIUM		SG IRON	
				Model Code	List Price	Model Code	List Price
inch	.50 NPTF	.375 NPTF	.25 NPTF	VSB		VSB/S	
inch	SAE-10	SAE-8	SAE-4	VSM		VSM/S	
metric	.50 BSPP	.375 BSPP	.25 BSPP	VPB		VPB/S	

Bar Manifold Mounting Kits to be ordered separately. See page 12.087.

ISO 03 Parallel Circuit with Relief Cavity

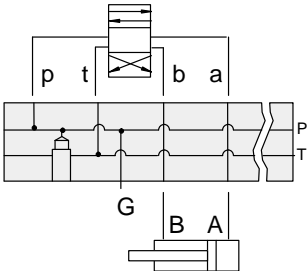

FUNCTION

Three Station

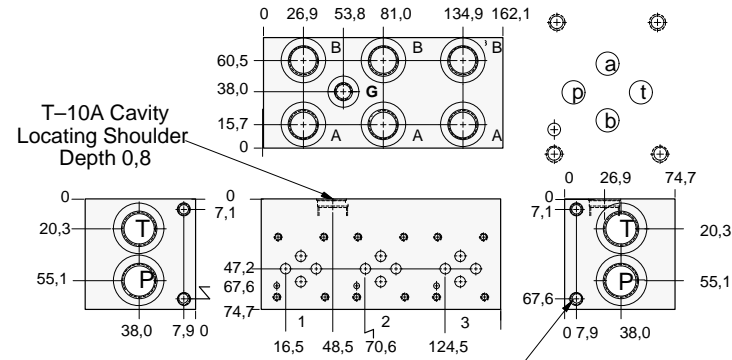

Mounting Holes:
 Inch: .312 – 18UNC x 11,2 mm Deep.
 Metric: M8 x 1.25 – 6H x 11,2 mm Deep.
 2 places each end.

Mounting Holes	Ports P, T	Ports A, B	Gauge Port	ALUMINIUM		SG IRON	
				Model Code	List Price	Model Code	List Price
inch	.50 NPTF	.375 NPTF	.25 NPTF	VSC		VSC/S	
inch	SAE-10	SAE-8	SAE-4	VSN		VSN/S	
metric	.50 BSPP	.375 BSPP	.25 BSPP	VPC		VPC/S	

Bar Manifold Mounting Kits to be ordered separately. See page 12.087.

TYPICAL CARTRIDGES USED WITH BODIES SHOWN ABOVE

	Pilot Operated Relief Valve		Direct Acting Relief Valve
	RPEC Page 1.06		RDDA Page 1.10
OTHER VALVES:			



BAR MANIFOLDS



- Aluminium rated to 210 bar and SG Iron rated to 350 bar.
- See page viii for ordering cartridge/body and seals. Pressure ratings, material specifications on page xiv.

ISO 03 Parallel Circuit with Relief Cavity

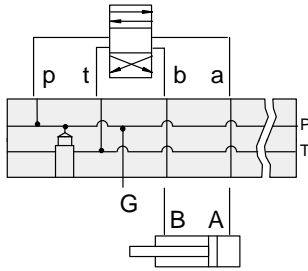

FUNCTION

Four Station

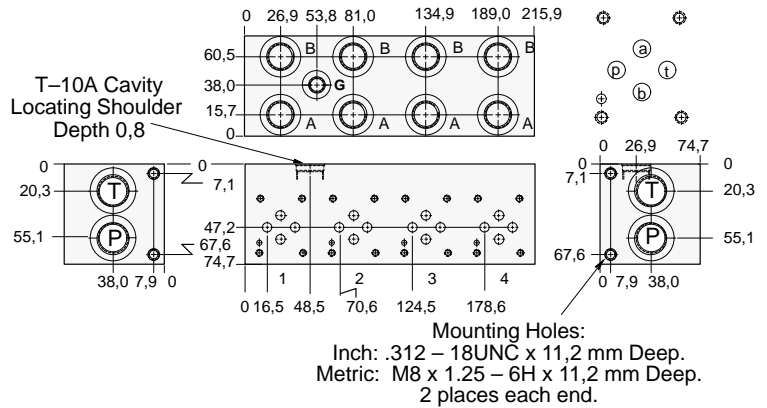

Mounting Holes	Ports P, T	Ports A, B	Gauge Port	ALUMINIUM		SG IRON	
				Model Code	List Price	Model Code	List Price
inch	.50 NPTF	.375 NPTF	.25 NPTF	VSD		VSD/S	
inch	SAE-10	SAE-8	SAE-4	VSP		VSP/S	
metric	.50 BSPP	.375 BSPP	.25 BSPP	VPD		VPD/S	

Bar Manifold Mounting Kits to be ordered separately. See page 12.087.

ISO 03 Parallel Circuit with Relief Cavity

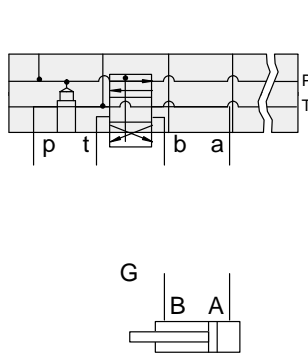

FUNCTION

Five Station

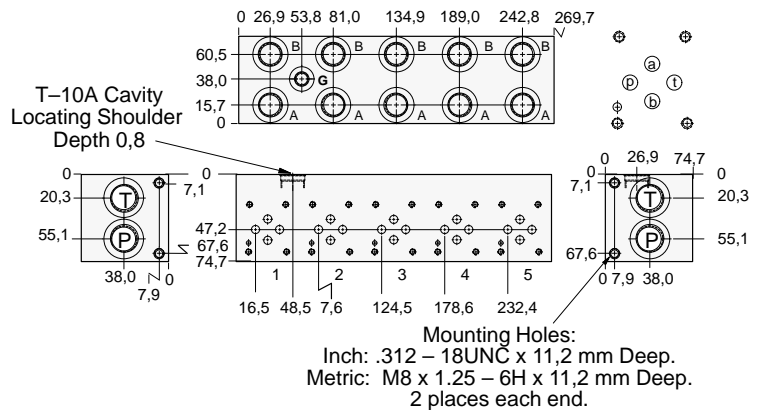

Mounting Holes	Ports P, T	Ports A, B	Gauge Port	ALUMINIUM		SG IRON	
				Model Code	List Price	Model Code	List Price
inch	.50 NPTF	.375 NPTF	.25 NPTF	VSE		VSE/S	
inch	SAE-10	SAE-8	SAE-4	VSR		VSR/S	
metric	.50 BSPP	.375 BSPP	.25 BSPP	VPE		VPE/S	

Bar Manifold Mounting Kits to be ordered separately. See page 12.087.

TYPICAL CARTRIDGES USED WITH BODIES SHOWN ABOVE

Cartridge Diagram	Valve Type	Page Reference
	Pilot Operated Relief Valve	RPEC Page 1.06
	Direct Acting Relief Valve	RDDA Page 1.10
OTHER VALVES:		