

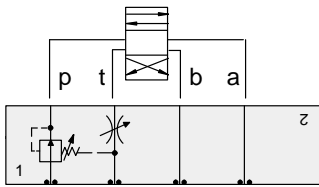

ISO 03 SANDWICH BODIES



- Aluminium rated to 210 bar and SG Iron rated to 350 bar.
- See page viii for ordering cartridge/body and seals. Pressure ratings, material specifications on page xiv.



FUNCTION

Pilot Choke

Circuit Savers

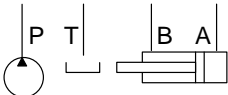
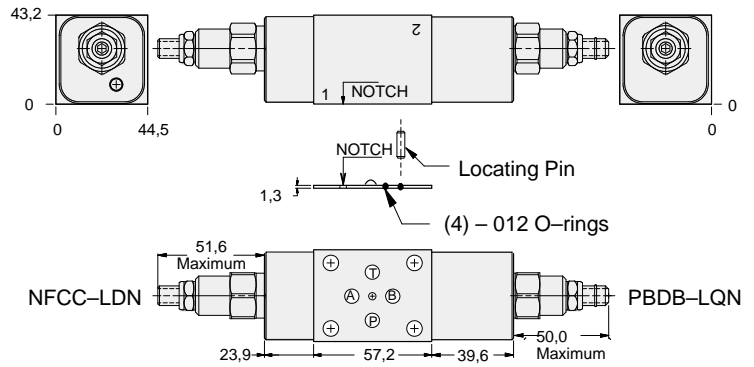

ALUMINIUM		SG IRON	
Model Code	List Price	Part Number	List Price
YNAA-LDN-AA		YNAA-LDN-AA/S	



ISO 03 SANDWICH BODIES



- Aluminium rated to 210 bar and SG Iron rated to 350 bar.
- See page viii for ordering cartridge/body and seals. Pressure ratings, material specifications on page xiv.

03 CIRCUIT SAVER

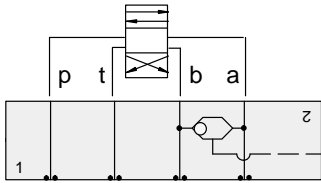

FUNCTION

Shuttle
A and B
Output External

Circuit Savers

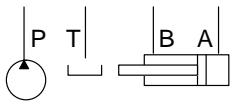
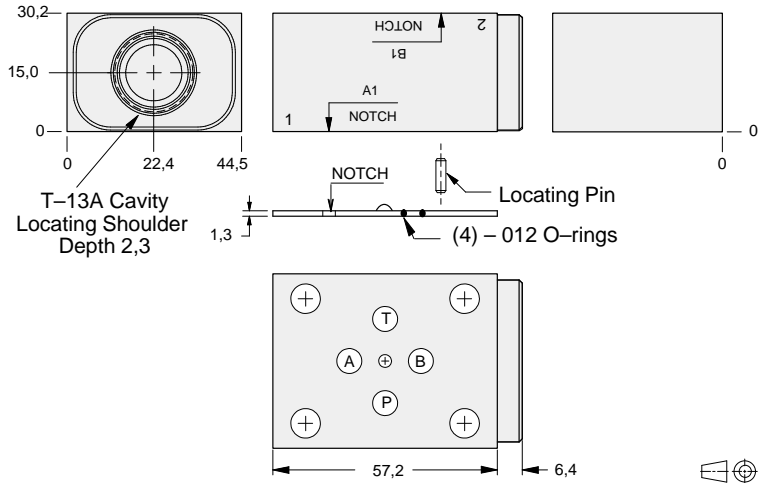

ALUMINIUM		SG IRON	
Model Code	List Price	Model Code	List Price
GBS		GBS/S	

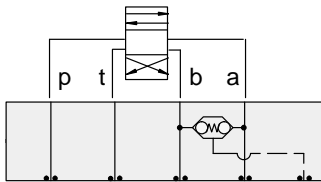

FUNCTION

Checks from
A and B-Adapter
to ISO 05 w/Y Port

Circuit Savers

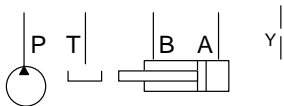
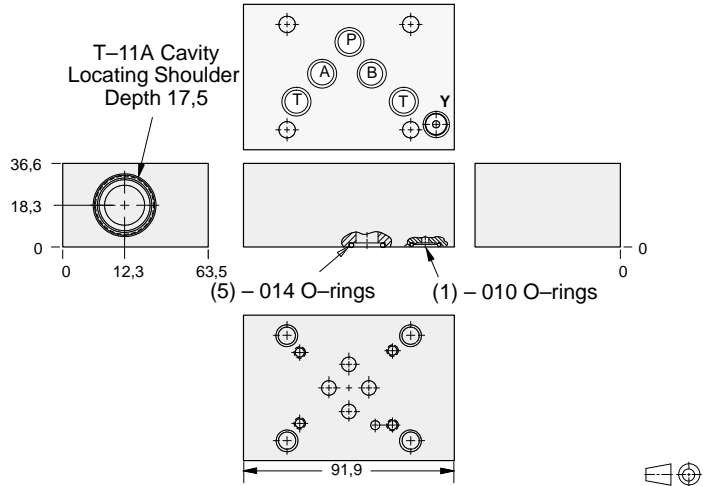

ALUMINIUM		SG IRON	
Model Code	List Price	Part Number	List Price
EBS		EBS/S	

TYPICAL CARTRIDGES USED WITH BODIES SHOWN ABOVE

	2 Port Shuttle Valve, Signal External		
	CSAA Page 10.09 (use with GBS)		
	3 Port Back-to-Back Check Valve, Signal at Port 3		
	CDAB Page 10.10 (use with EBS)		
OTHER VALVES:			



ISO 03 SANDWICH BODIES



- Aluminium rated to 210 bar and SG Iron rated to 350 bar.
- See page viii for ordering cartridge/body and seals. Pressure ratings, material specifications on page xiv.

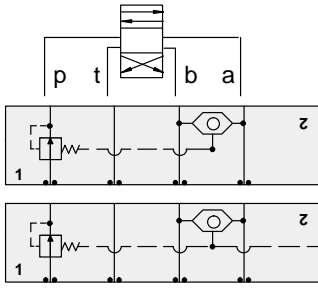

FUNCTION

Pressure Compensator (Restrictive)

Pressure Compensator (Restrictive) w/Load-Sensing Port

Circuit Savers

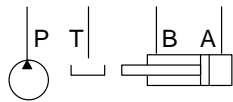
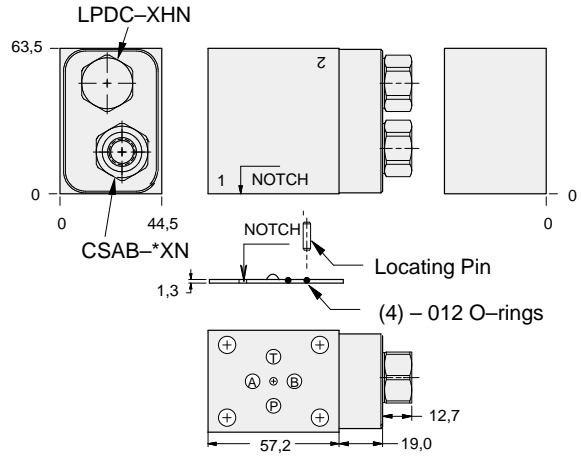

Shuttle Cartridge	External Shuttle Port	ALUMINIUM		SG IRON	
		Model Code	List Price	Model Code	List Price
CSAB-XXN	None	YFCG-XHN-AA		YFCG-XHN-AA/S	
CSAB-AXN	SAE-4	YFCJ-XHN-AA		YFCJ-XHN-AA/S	
CSAB-BXN	.250 BSPP	YFCJ-XHN-AA/M		YFCJ-XHN-AA/T	

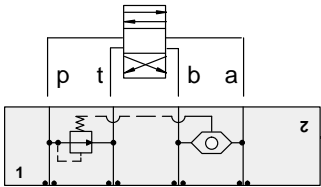

FUNCTION

Pressure Compensator (Bypass)

Circuit Savers

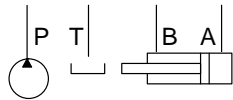
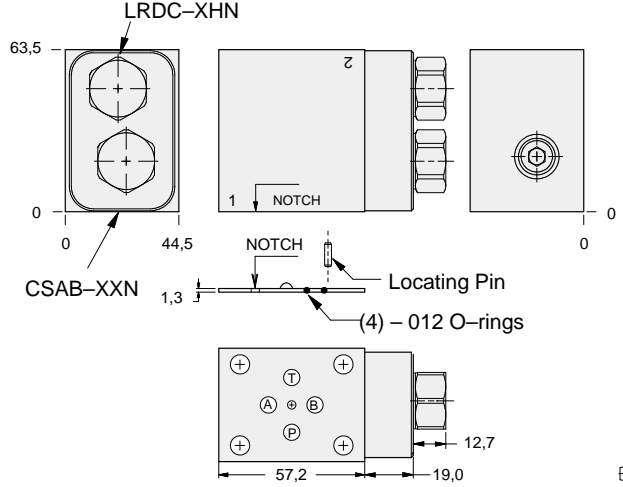

ALUMINIUM		SG IRON	
Model Code	List Price	Part Number	List Price
YFCG-XHN-AA		YFCG-XHN-AA/S	



ISO 03 SANDWICH BODIES



- Aluminium rated to 210 bar and SG Iron rated to 350 bar.
- See page viii for ordering cartridge/body and seals. Pressure ratings, material specifications on page xiv.

03 CIRCUIT SAVER

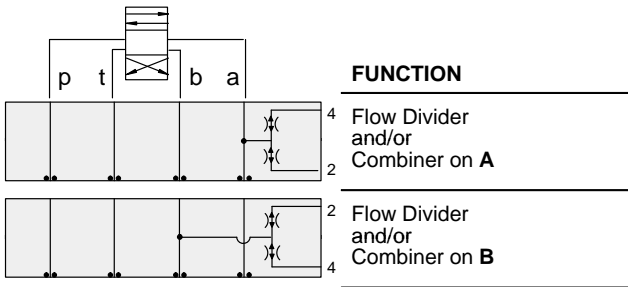

FUNCTION

4 Flow Divider and/or Combiner on A

2 Flow Divider and/or Combiner on B

Circuit Savers

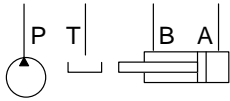
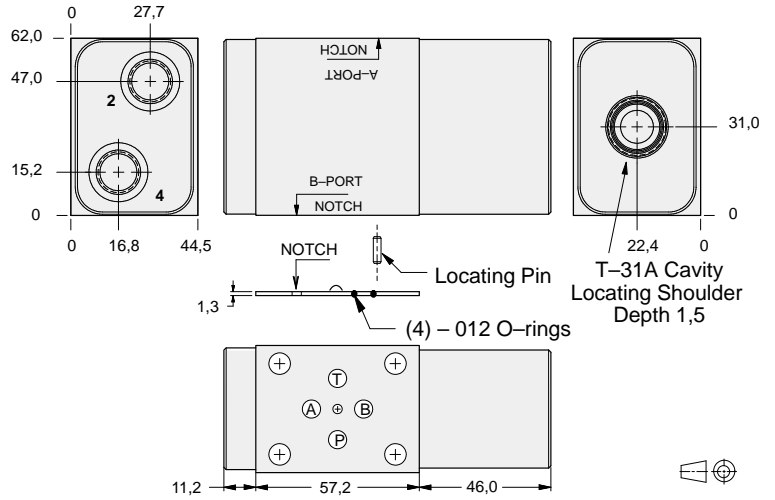

Ports 2,4	ALUMINIUM		SG IRON	
	Model Code	List Price	Model Code	List Price
SAE-6	MBJ		MBJ/S	
.25 BSPP	MBJ/M		MBJ/T	

TYPICAL CARTRIDGES USED WITH BODIES SHOWN ABOVE

	Flow Divider		High Capacity Flow Divider/Combiner
	FSBD, FSCD Page 7.08		FSCH Page 7.14
	Flow Divider/Combiner		
	FSBA, FSCA Page 7.10		
	Synchronizing Flow Divider/Combiner		
	FSBS, FSCS Page 7.12		
OTHER VALVES:			



ISO 03 SANDWICH BODIES



- Aluminium rated to 210 bar and SG Iron rated to 350 bar.
- See page viii for ordering cartridge/body and seals. Pressure ratings, material specifications on page xiv.

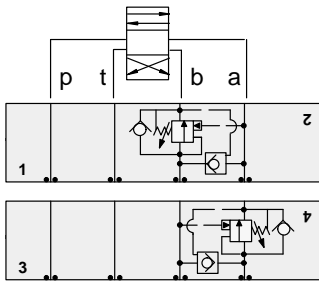

FUNCTION

B to A
Regenerative

A to B
Regenerative

Circuit Savers

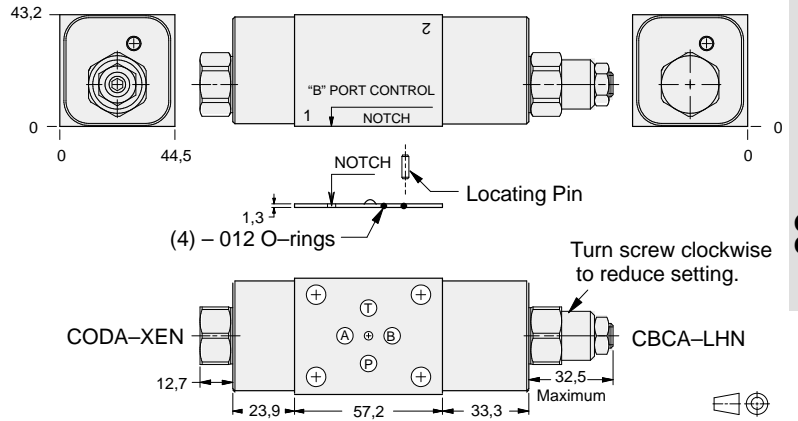

03 CIRCUIT SAVER

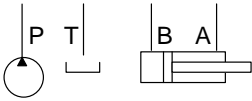

ALUMINIUM		SG IRON	
Model Code	List Price	Model Code	List Price
YDCA-LHN-AA		YDCA-LHN-AA/S	



ISO 03 SANDWICH BODIES



- Aluminium rated to 210 bar and SG Iron rated to 350 bar.
- See page viii for ordering cartridge/body and seals. Pressure ratings, material specifications on page xiv.

03 CIRCUIT SAVER

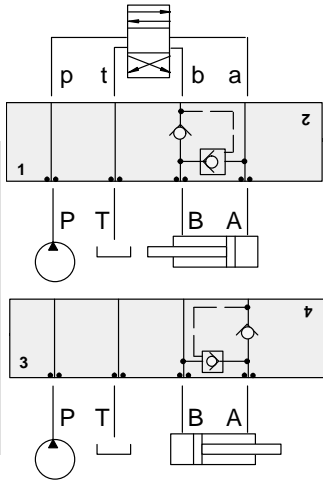

FUNCTION

B to A
Regenerative
(Full Time)

A to B
Regenerative
(Full Time)

Circuit Savers

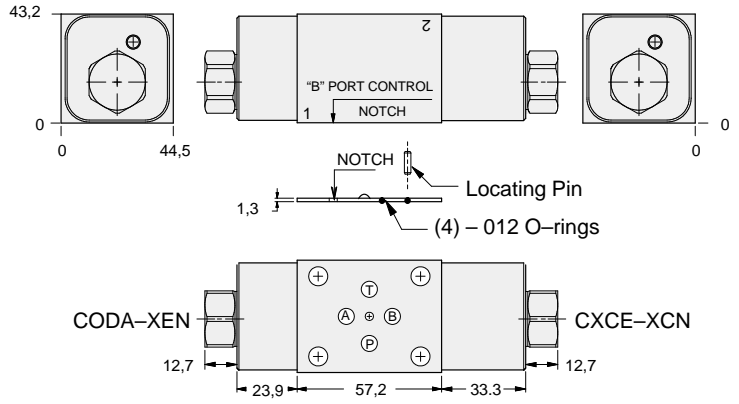

ALUMINIUM		SG IRON	
Model Code	List Price	Model Code	List Price
YDCF-XCN-AA		YDCF-XCN-AA/S	



ISO 03 SANDWICH BODIES



- Aluminium rated to 210 bar and SG Iron rated to 350 bar.
- See page viii for ordering cartridge/body and seals. Pressure ratings, material specifications on page xiv.

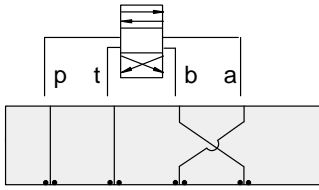

FUNCTION

Swap Block
Swaps A and B

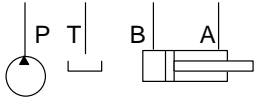

ALUMINIUM		SG IRON	
Model Code	List Price	Model Code	List Price
ZKX		ZKX/S	

Circuit Savers

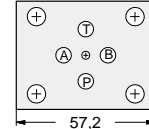
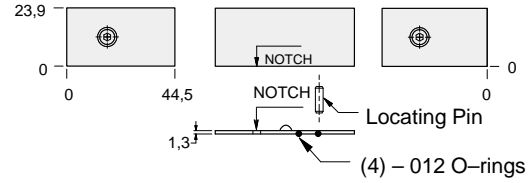

Circuit Savers

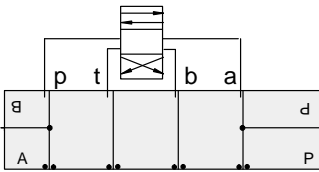
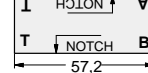
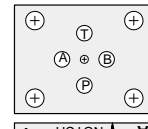
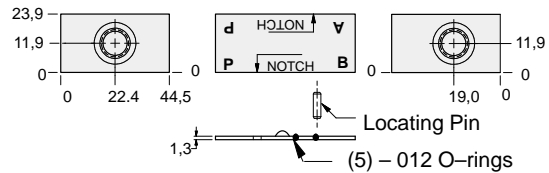

FUNCTION

P and A
Tap in Manifold

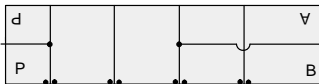

P and B
Tap in Manifold

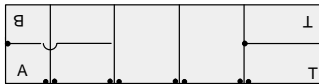

A and T
Tap in Manifold

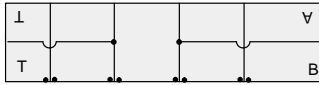

B and T
Tap in Manifold

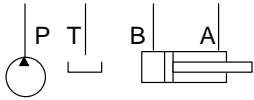

External Port	ALUMINIUM		SG IRON	
	Model Code	List Price	Model Code	List Price
.25 NPTF	ZWW		ZWW/S	
SAE-4	ZPT		ZPT/S	
.25 BSPP	ZVC		ZVC/S	

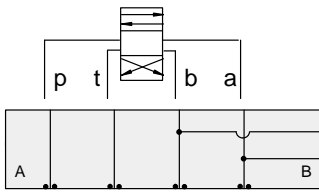

FUNCTION

A and B
Tap in Manifold

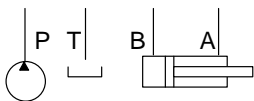

Circuit Savers

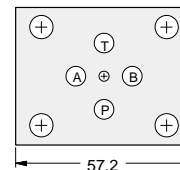
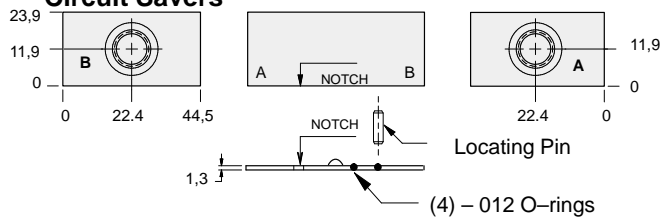

Ports A, B	ALUMINIUM		SG IRON	
	Model Code	List Price	Model Code	List Price
.25 NPTF	ZWV		ZWV/S	
SAE-4	ZUO		ZUO/S	
.25 BSPP	ZVB		ZVB/S	