

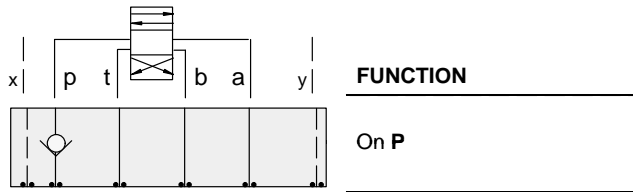

ISO 08 SANDWICH BODIES



- Aluminium rated to 210 bar and SG Iron rated to 350 bar.
- See page viii for ordering cartridge/body and seals. Pressure ratings, material specifications on page xiv.



Check Valves

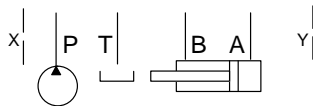
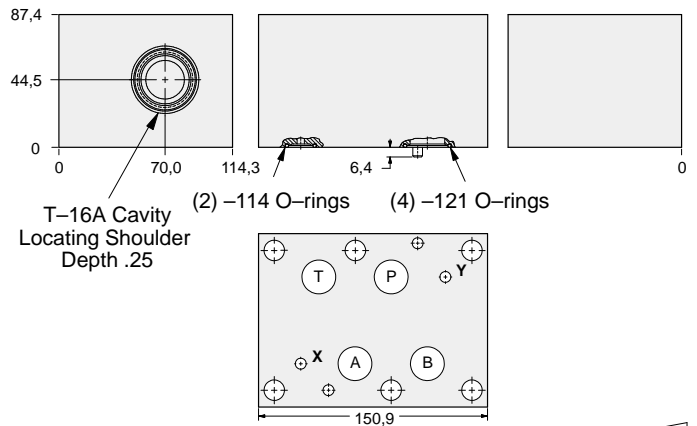

ALUMINIUM		SG IRON	
Model Code	List Price	Model Code	List Price
IBP		IBP/S	

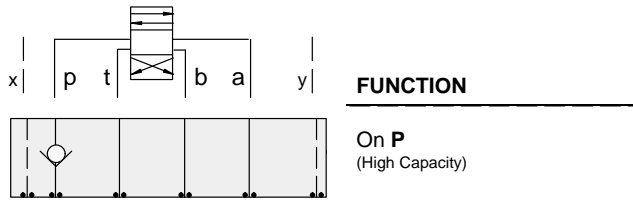

Check Valves

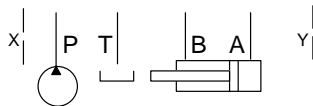
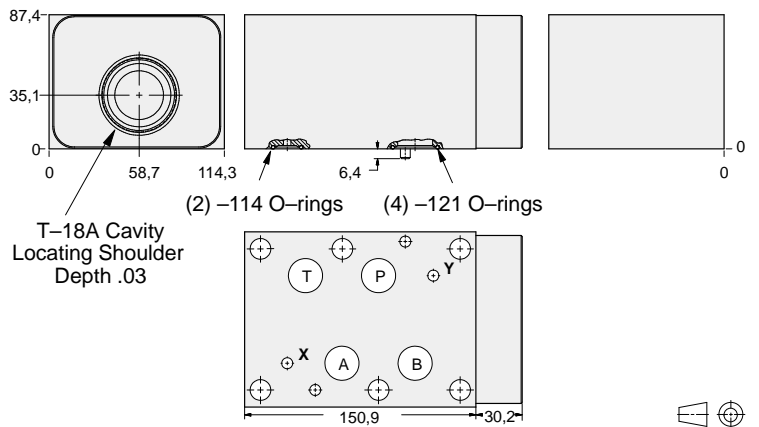

ALUMINIUM		SG IRON	
Model Code	List Price	Part Number	List Price
IBO		IBO/S	

TYPICAL CARTRIDGES USED WITH BODIES SHOWN ABOVE

	Check Valve, Free Flow Port 1 to Port 2 (Nose-to-Side)		
	CX*A Page 5.09		
OTHER VALVES:			



ISO 08 SANDWICH BODIES



- Aluminium rated to 210 bar and SG Iron rated to 350 bar.
- See page viii for ordering cartridge/body and seals. Pressure ratings, material specifications on page xiv.

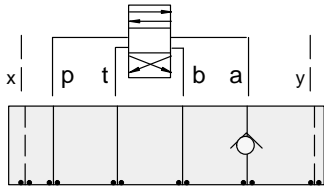

FUNCTION

On A
Free Flow Out
of Valve

Check Valves

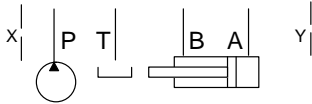
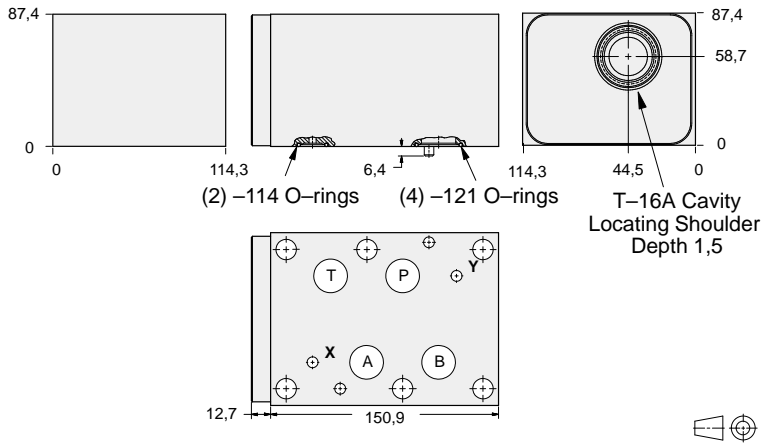

ALUMINIUM		SG IRON	
Model Code	List Price	Model Code	List Price
IBC		IBC/S	

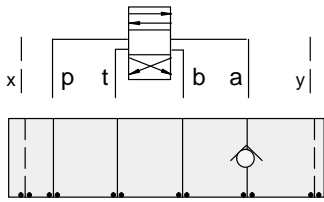

FUNCTION

On A
Free Flow Out
of Valve (High Capacity)

Check Valves

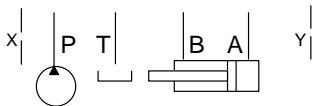
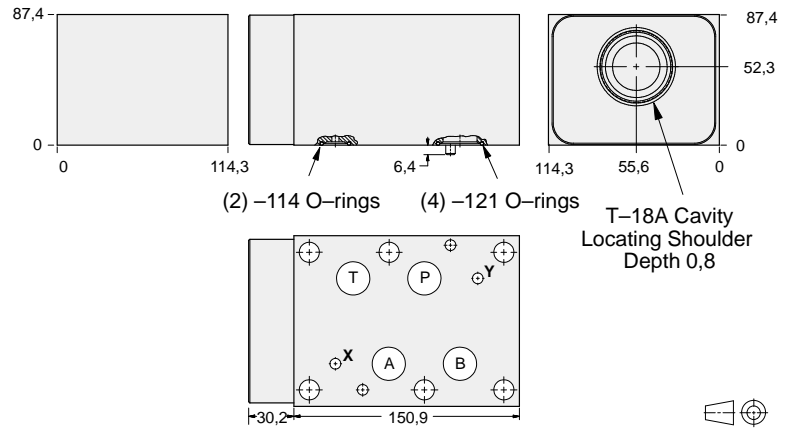

ALUMINIUM		SG IRON	
Model Code	List Price	Part Number	List Price
IBG		IBG/S	

TYPICAL CARTRIDGES USED WITH BODIES SHOWN ABOVE

	Check Valve, Free Flow Port 1 to Port 2 (Nose-to-Side)		
	CX*A Page 5.09		
OTHER VALVES:			

08 CHECK



ISO 08 SANDWICH BODIES



- Aluminium rated to 210 bar and SG Iron rated to 350 bar.
- See page viii for ordering cartridge/body and seals. Pressure ratings, material specifications on page xiv.

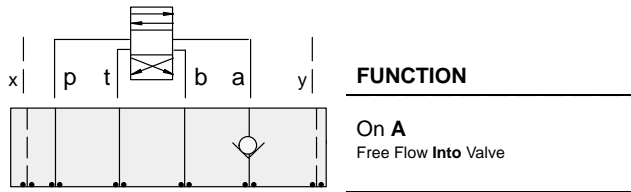

FUNCTION

On A
Free Flow Into Valve

Check Valves

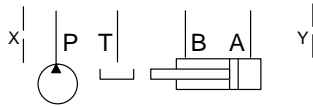
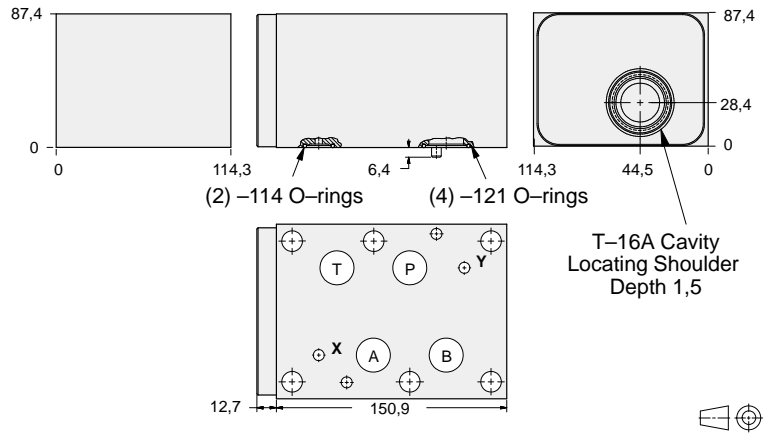

ALUMINIUM		SG IRON	
Model Code	List Price	Model Code	List Price
IBA		IBA/S	

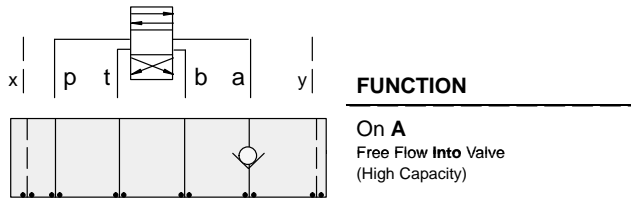

FUNCTION

On A
Free Flow Into Valve
(High Capacity)

Check Valves

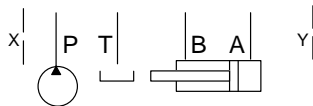
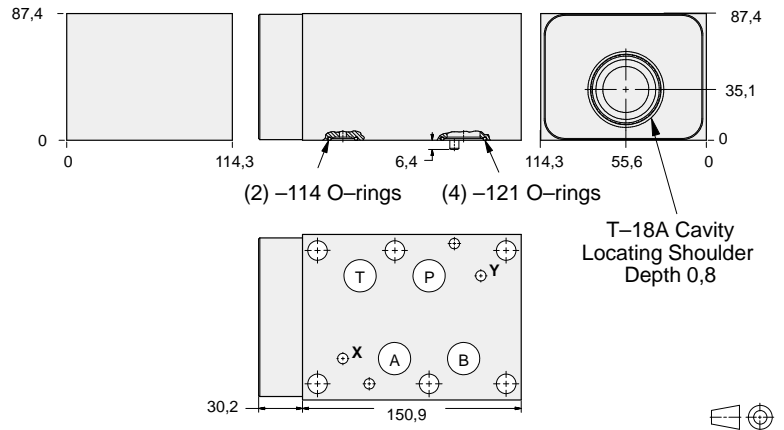

ALUMINIUM		SG IRON	
Model Code	List Price	Part Number	List Price
IBE		IBE/S	

TYPICAL CARTRIDGES USED WITH BODIES SHOWN ABOVE			
	Check Valve, Free Flow Port 1 to Port 2 (Nose-to-Side)		
	CX*A Page 5.09		
OTHER VALVES:			



ISO 08 SANDWICH BODIES



- Aluminium rated to 210 bar and SG Iron rated to 350 bar.
- See page viii for ordering cartridge/body and seals. Pressure ratings, material specifications on page xiv.

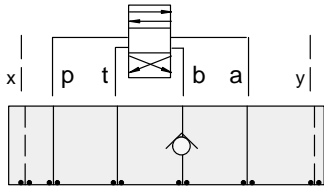

FUNCTION

On B
Free Flow Out
of Valve

Check Valves

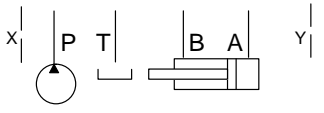
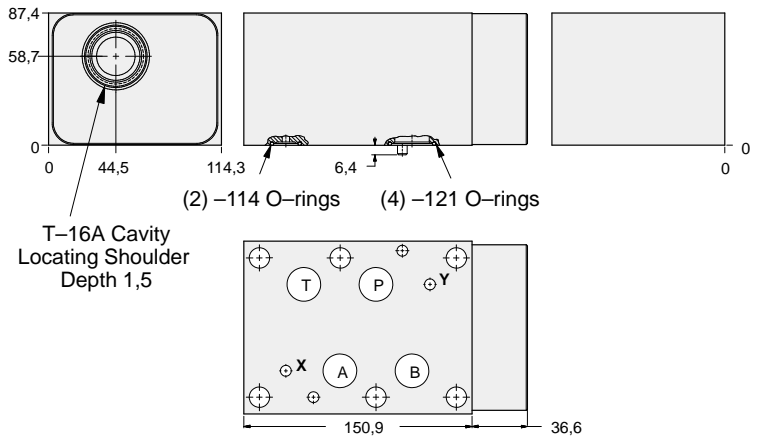

ALUMINIUM		SG IRON	
Model Code	List Price	Model Code	List Price
IBD		IBD/S	

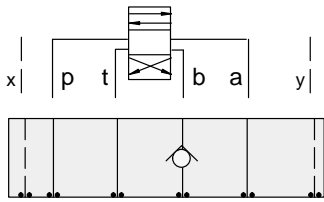

FUNCTION

On B
Free Flow Out
of Valve (High Capacity)

Check Valves

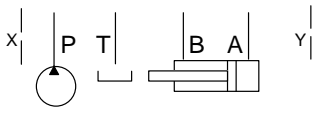
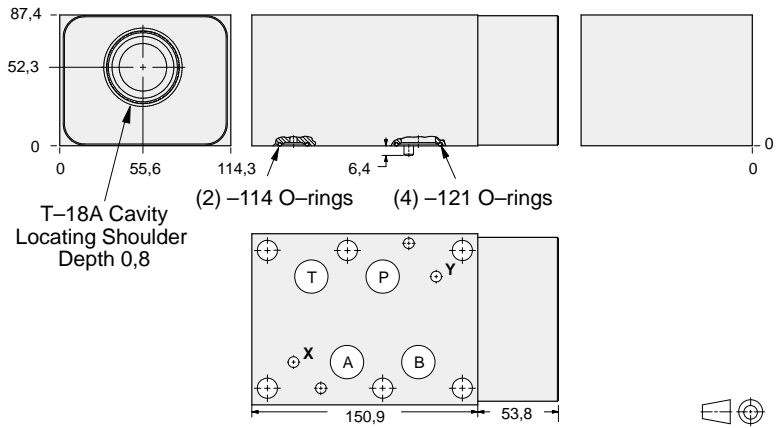

ALUMINIUM		SG IRON	
Model Code	List Price	Part Number	List Price
IBH		IBH/S	

TYPICAL CARTRIDGES USED WITH BODIES SHOWN ABOVE

	Check Valve, Free Flow Port 1 to Port 2 (Nose-to-Side)		
	CX*A Page 5.09		
OTHER VALVES:			

08 CHECK



ISO 08 SANDWICH BODIES



- Aluminium rated to 210 bar and SG Iron rated to 350 bar.
- See page viii for ordering cartridge/body and seals. Pressure ratings, material specifications on page xiv.

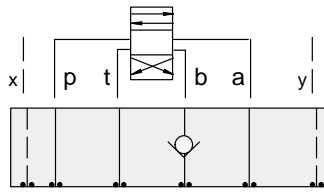

FUNCTION

On B
Free Flow Into Valve

Check Valves

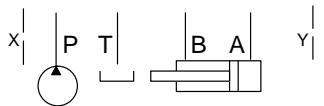
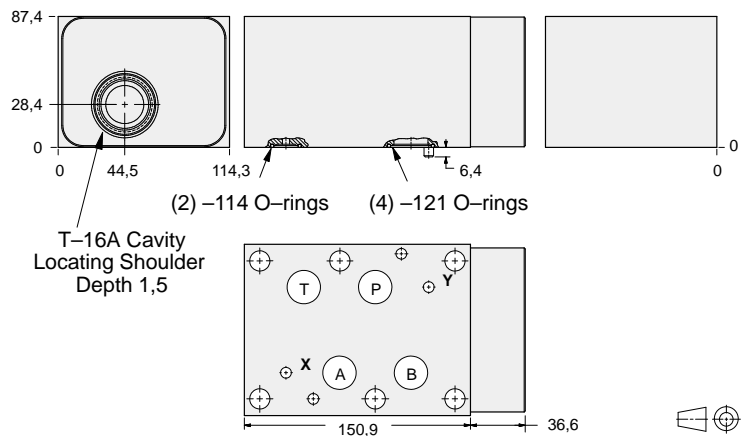

ALUMINIUM		SG IRON	
Model Code	List Price	Model Code	List Price
IBB		IBB/S	

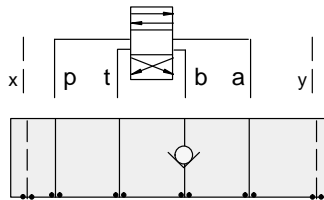

FUNCTION

On B
Free Flow Into Valve
(High Capacity)

Check Valves

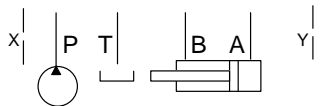
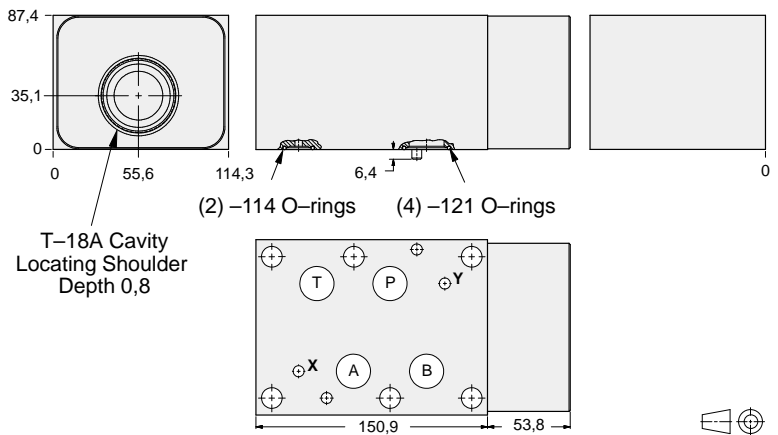

ALUMINIUM		SG IRON	
Model Code	List Price	Part Number	List Price
IBF		IBF/S	

TYPICAL CARTRIDGES USED WITH BODIES SHOWN ABOVE			
	Check Valve, Free Flow Port 1 to Port 2 (Nose-to-Side)		
	CX*A Page 5.09		
OTHER VALVES:			

08 CHECK



ISO 08 SANDWICH BODIES



- Aluminium rated to 210 bar and SG Iron rated to 350 bar.
- See page viii for ordering cartridge/body and seals. Pressure ratings, material specifications on page xiv.

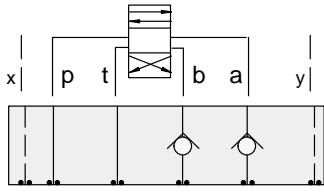

FUNCTION

On **A** and **B**
Free Flow **Out**
of Valve

Check Valves

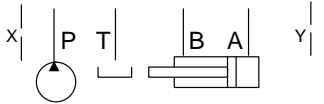
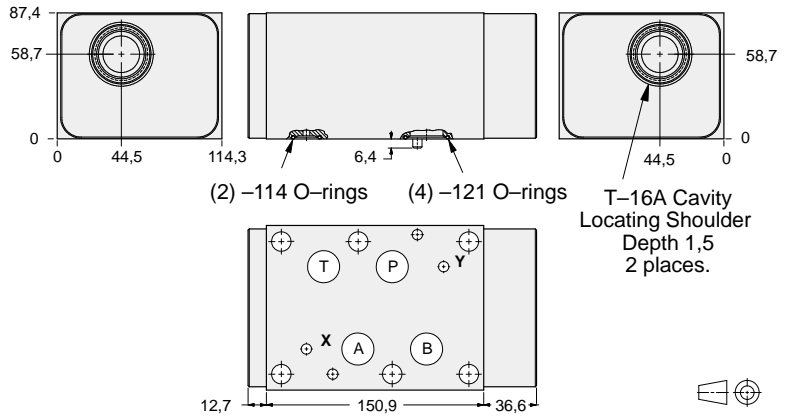

ALUMINIUM		SG IRON	
Model Code	List Price	Model Code	List Price
IBX		IBX/S	

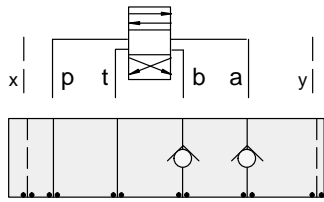

FUNCTION

On **A** and **B**
Free Flow **Out**
of Valve (High Capacity)

Check Valves

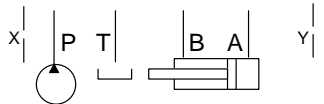
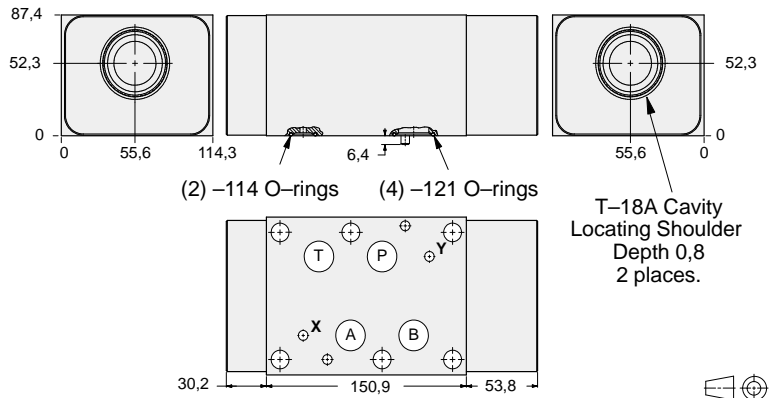

ALUMINIUM		SG IRON	
Model Code	List Price	Part Number	List Price
IBZ		IBZ/S	

TYPICAL CARTRIDGES USED WITH BODIES SHOWN ABOVE

	Check Valve, Free Flow Port 1 to Port 2 (Nose-to-Side)		
	CX*A Page 5.09		
OTHER VALVES:			

08 CHECK



ISO 08 SANDWICH BODIES



- Aluminium rated to 210 bar and SG Iron rated to 350 bar.
- See page viii for ordering cartridge/body and seals. Pressure ratings, material specifications on page xiv.

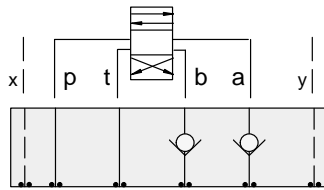

FUNCTION

On **A** and **B**
Free Flow Into Valve

Check Valves

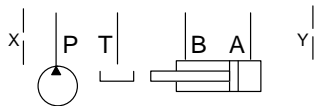
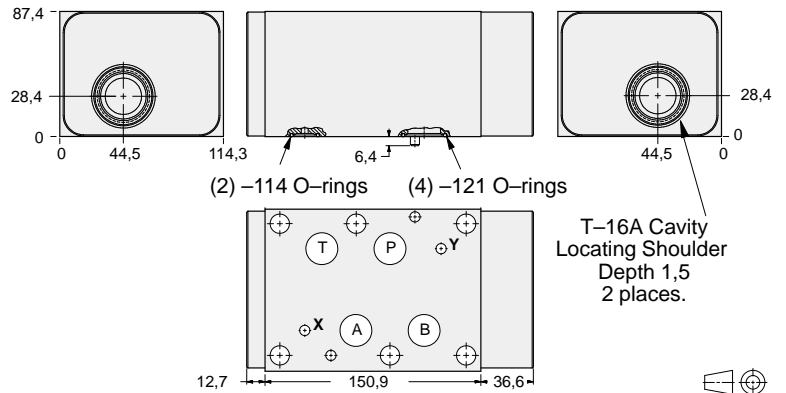

ALUMINIUM		SG IRON	
Model Code	List Price	Model Code	List Price
IBW		IBW/S	

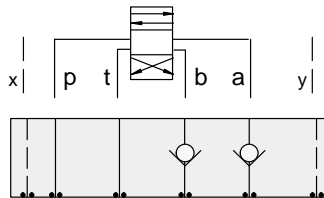

FUNCTION

On **A**
Free Flow Into Valve
(High Capacity)

Check Valves

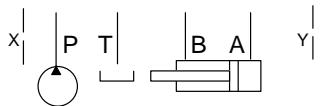
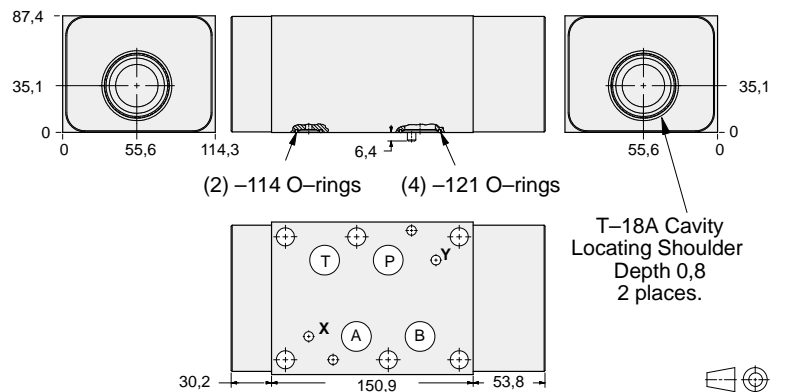

ALUMINIUM		SG IRON	
Model Code	List Price	Part Number	List Price
IBY		IBY/S	

TYPICAL CARTRIDGES USED WITH BODIES SHOWN ABOVE			
	Check Valve, Free Flow Port 1 to Port 2 (Nose-to-Side)		
	CX*A Page 5.09		
OTHER VALVES:			



ISO 08 SANDWICH BODIES



- Aluminium rated to 210 bar and SG Iron rated to 350 bar.
- See page viii for ordering cartridge/body and seals. Pressure ratings, material specifications on page xiv.

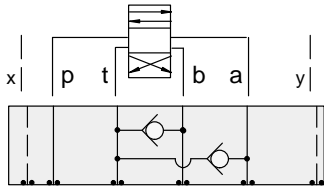

FUNCTION

T to A and B

Check Valves

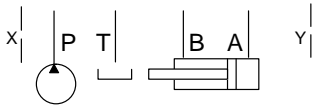
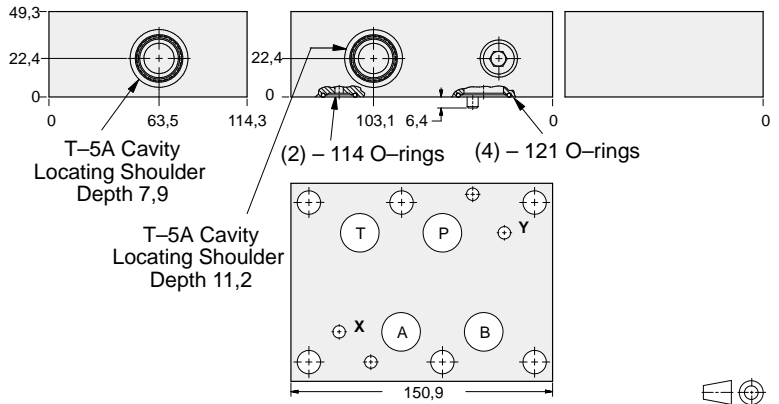

ALUMINIUM		SG IRON	
<i>Model Code</i>	<i>List Price</i>	<i>Model Code</i>	<i>List Price</i>
CDX		CDX/S	

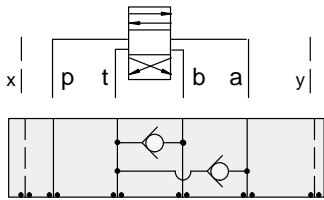

FUNCTION

**T to A and B
(High Capacity)**

Check Valves

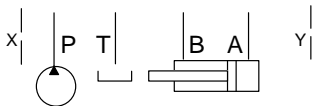
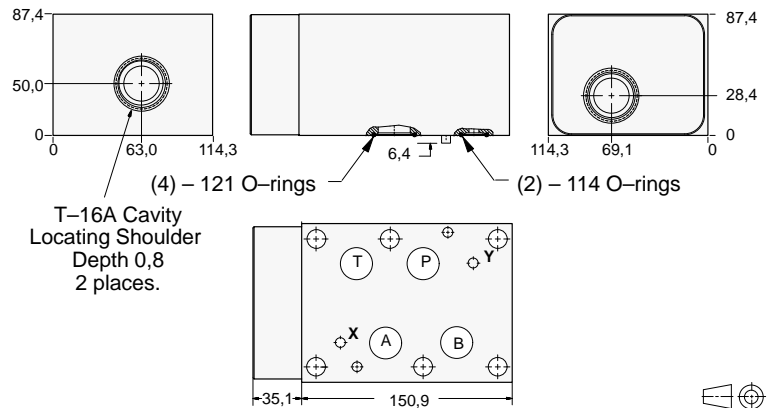

ALUMINIUM		SG IRON	
<i>Model Code</i>	<i>List Price</i>	<i>Part Number</i>	<i>List Price</i>
CDV		CDV/S	

TYPICAL CARTRIDGES USED WITH BODIES SHOWN ABOVE

	Check Valve, Free Flow Port 1 to Port 2 (Nose-to-Side)		
	CX*A Page 5.08, 5.09		
OTHER VALVES:			

08 CHECK



ISO 08 SANDWICH BODIES



- Aluminium rated to 210 bar and SG Iron rated to 350 bar.
- See page viii for ordering cartridge/body and seals. Pressure ratings, material specifications on page xiv.

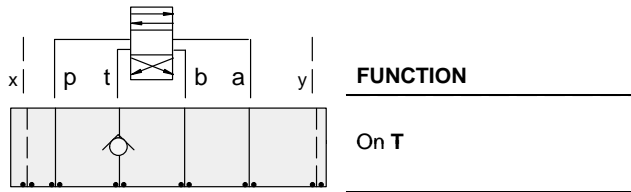

Check Valves

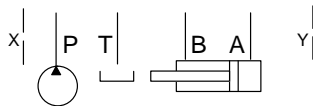
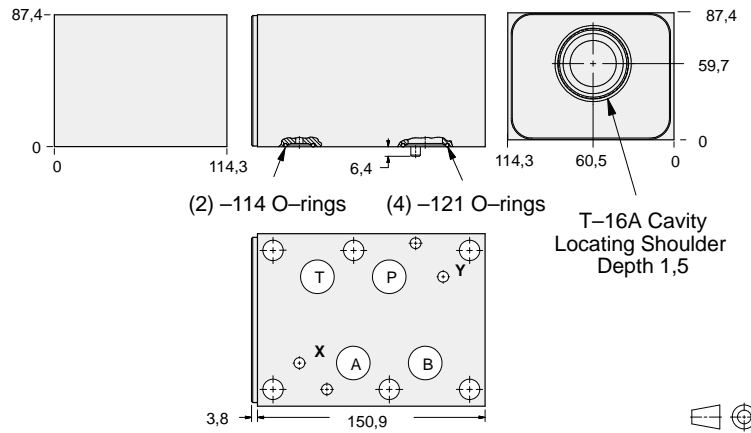

ALUMINIUM		SG IRON	
Model Code	List Price	Model Code	List Price
IBT		IBT/S	

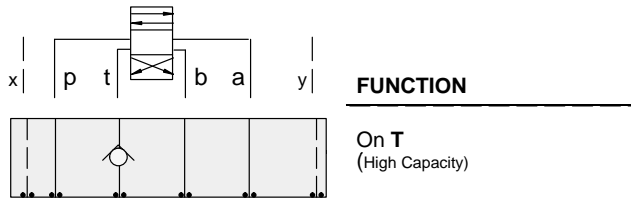

Check Valves

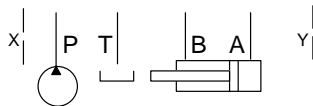
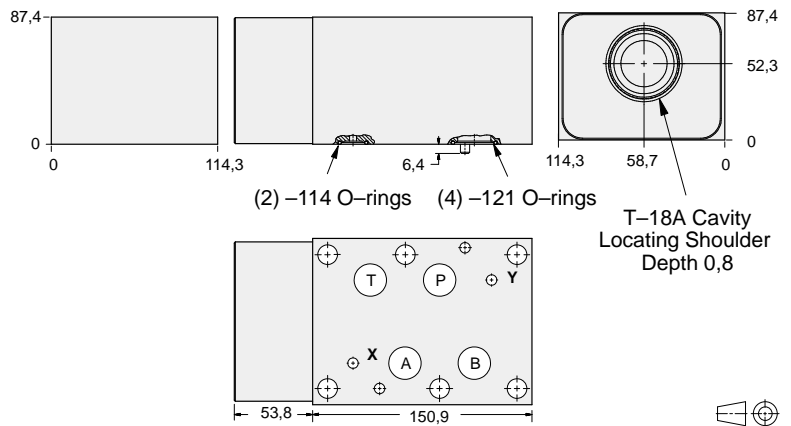

ALUMINIUM		SG IRON	
Model Code	List Price	Part Number	List Price
IBV		IBV/S	

TYPICAL CARTRIDGES USED WITH BODIES SHOWN ABOVE			
	Check Valve, Free Flow Port 1 to Port 2 (Nose-to-Side)		
	CX*A Page 5.09		
OTHER VALVES:			