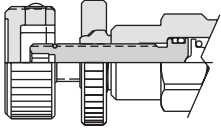
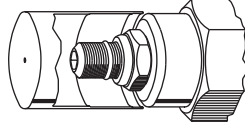
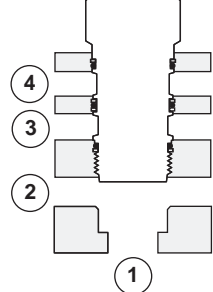
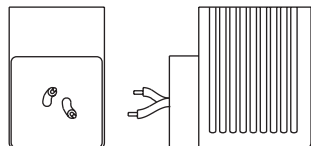
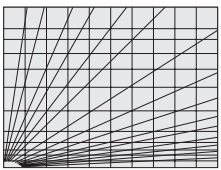
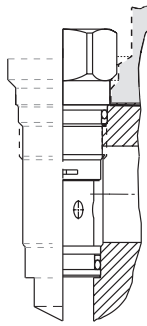

# General Information

	<i>Page</i>	
Cartridge Control Options	244	
Cartridge Control Kits	245	
Cavity Plugs	246	
Solenoid Electrical Connector Options	248	
Pressure Drop Data Chart	249	
Cartridge Cavities and Cavity Tools	250	

**CARTRIDGE CONTROL OPTIONS**

**General Purpose Controls**

**L Standard Screw Adjustment**

O-ring seal on adjust screw. Adjust screw positively retained. Overset protection-pilot spring cannot go solid.

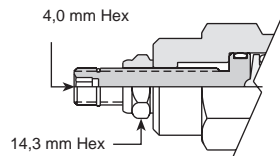

**K Handknob with Lock Knob**

Handknob and lock knob added to L control. Sun handknob kits for field conversion are available. See cartridge control kits.

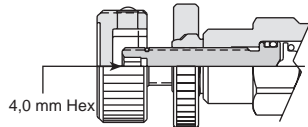

**O Handknob with Panel Mount**

Special threaded cartridge hex body with panel nut for mounting cartridge through access hole in control panel. Handknob and lock knob included.

Panel Hole:

- Series 1 cartridges 19,0 mm dia.
- Series 2 cartridges 25,4 mm dia.

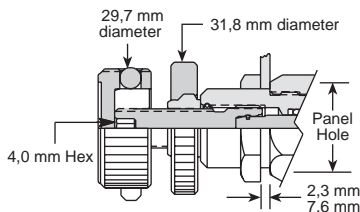

**C Tamper Resistant Factory Set**

Steel cover press-fits onto L control cartridge shoulder. Valves may be ordered in this configuration. **Specify pressure setting on order.** Setting stamped on cartridge hex. Kits for field conversion are available. See cartridge control kits.

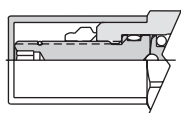

**Key Lock Kit**

Optional adjustment Key Lock Cover Kit for L controls allows adjustment to be locked with a key to prevent changes in valve setting. Adjustment easily accessible when lock assembly is removed.

Requires replacement of standard locknut with special locknut which accepts assembly, and new wire stop ring for overset protection.

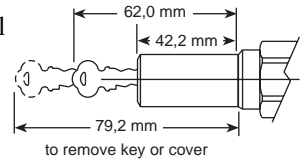

**H Calibrated Handknob with Detent Lock**

Fully calibrated handknob for flow control cartridges. 40 radial calibrations per turn. Moveable zero indicator. (Minor disassembly required.) Rising detented locking collar positively locks adjustment knob against vibration or accidental tampering. Any desired setting may be recorded and repeated. U.S. Patent #4,577,831

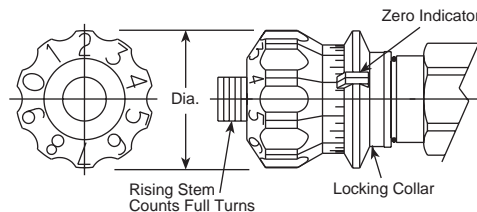

Diameter	28,7 mm	35,1 mm	41,1 mm	41,1 mm
Series	1	2	3	4
	NCCB	NCEB	NCFB	NCGB
	NCCC	NCEC	NCFC	NCGC
	NFCC	NFDC	NFEC	NFFC
	NFCD	NFDD	NFED	NFFD
	FDBA	FDCB	FDEA	FDFA

**Special Purpose Controls** (for use in systems where adjustment is seldom changed after installation)

**J Socket Head Set Screw with Cap**

Stem seal O-ring under locknut. Adjusting screw is not retained. No overset protection.

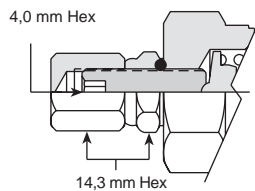

**F Wrench Adjustment**

Stem seal O-ring under locknut. Adjusting screw is not retained. Overset protection-pilot spring cannot go solid.

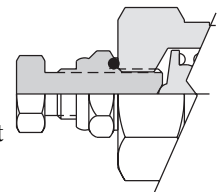

**Counterbalance Valves**

All Sun counterbalance cartridges are built with a leakproof adjustment (O-ring seals on the adjusting screw) but are not designed for frequent adjustment in the field. Cartridges that are factory pre-set by Sun to a customer specified pressure setting are available and can be installed directly on a machine without the need for further adjustment.

**L Standard Leakproof Screw Adjustment.**



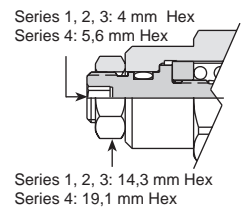

O-ring seal on adjust screw.

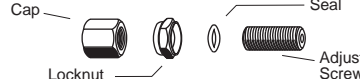
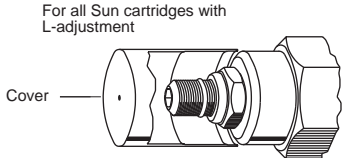
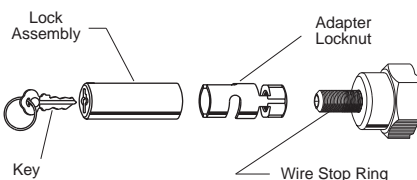

**C Tamper Resistant Factory Set**

See C Control description above.

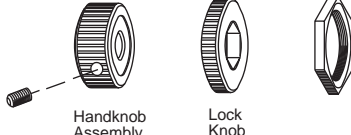
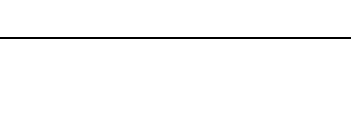
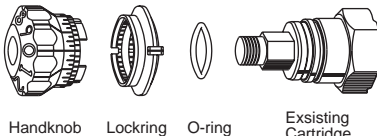
**CARTRIDGE CONTROL KITS**

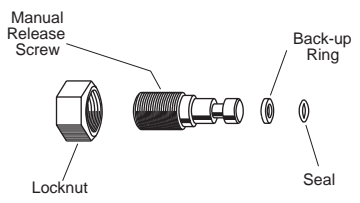
Service Kit Number Description	Use specifically with Control/Cartridge	Description	Notes
Adjustment Screw Kit <b>991-006</b>	All <b>F</b> controls		To assure a complete seal on the stem - release all pressure on the cartridge after setting. <b>Then...</b> tighten locknut (and cap, on <b>J</b> ).
Adjustment Screw Kit <b>991-010</b>	All <b>J</b> controls		
Tamper Resistant Cover <b>991-000</b> <b>991-004</b> <b>991-001</b> <b>991-002</b> <b>991-003</b>	For all Sun cartridges with <b>L</b> adjustment Series 0 - 19,0 mm (3/4") hex Series 1 - 22,2 mm (7/8") hex Series 2 - 28,6 mm (1 1/8") hex Series 3 - 31,8 mm (1 1/4") hex Series 4 - 41,0 mm (1 5/8") hex	<p>For all Sun cartridges with L-adjustment</p> 	<p><b>Tamper Resistant Cover</b></p> <ol style="list-style-type: none"> <li>1. Adjust valve to desired setting and tighten locknut.</li> <li>2. Using an arbor press or a soft hammer, install cover until it seats on cartridge hex.</li> <li>3. Cover is a press fit on cartridge shoulder.</li> </ol>
Key Lock Kit <b>993-008</b>	For all Sun cartridges with <b>L</b> adjustment (except Series 0 and counterbalance cartridges).		<ol style="list-style-type: none"> <li>1. Remove original wire stop ring and locknut.</li> <li>2. Thread on the adapter locknut and install new wire stop ring through slot provided.</li> <li>3. Adjust valve to desired setting and tighten adapter locknut.</li> <li>4. Slide lock assembly over adapter, lock and remove key.</li> </ol>
<b>K</b> Handknob Kit <b>991-211</b>  <b>991-222</b>	Use this kit to adapt all <b>L</b> controls to <b>K</b> controls (except Series 0 and counterbalance cartridges).  <b>K</b> control for Series 0		Only cartridges date stamped "41" or later and originally supplied with plastic knobs. Lock knob snaps onto locknut furnished on cartridge.
Panel Handknob Kit <b>991-215</b>	<b>O</b> controls All Series 1 cartridges 22,2 mm (7/8") hex M20 thread		
Panel Handknob Kit <b>991-216</b>	<b>O</b> controls All Series 2 cartridges 28,6 mm (1 1/8") hex 1"-14 thread		
<b>H</b> Calibrated Handknob Kit  <b>991-219</b>  <b>991-220</b>  <b>991-221</b>	<b>H</b> controls All series of flow controls  <b>FDCB, NCEB, NCEC, NFDC, NFDD</b> only  <b>FDEA, FDFA, NCFB, NCFE, NCFD, NCFB, NCFE, NCFD, NCFB, NCFE, NCFD</b> only  <b>FDBA, NCCB, NCCC, NFCC, NFDC</b> only		<p>Only for cartridges originally supplied with an <b>H</b> handknob. Valves can not be modified in the field.</p> <p><b>Note:</b> The <b>H</b> control is <b>Only</b> available for the cartridges shown to the left.</p>
Lockwire <b>911-012</b>	All <b>M, Q</b> and <b>R</b> controls (except solenoid operated cartridges).		
Adjustment Screw Kit <b>991-112-003</b> Viton <b>991-112-007</b> Buna-N	For cartridge models: <b>CKCA L**CKCD L**</b> <b>CKCB L**CPCA L**</b> <b>CKCC L**</b>		<b>Only</b> cartridges date stamped "62" or earlier.
Adjustment Screw Kit <b>991-212-003</b> Viton <b>991-212-007</b> Buna-N	For cartridge models: <b>CKEA L**CKED L**</b> <b>CKEB L**CPEA L**</b> <b>CKEC L**</b>		

## General Information

### CAVITY PLUGS

It is sometimes desirable to remove a Sun cartridge valve and still maintain the integrity of the hydraulic system. This may be necessitated by the need to flush a system after repairs or a piping change, or to change an operating function in the circuit. For these requirements, Sun offers two styles of cavity plugs - all ports blocked and main ports open to flow.

#### Plugs for Two Port Cavities:

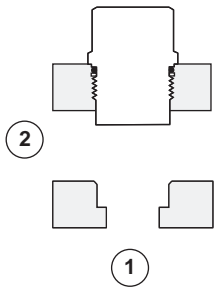

Series	Cavity	All Ports Open	All Ports Blocked
		Cavity Plug Model Code	Cavity Plug Model Code
P	T-8A	XAOA-XX*	XACA-XX*
0	T-162A	XZOA-XX*	XZCA-XX*
1	T-10A	XFOA-XX*	XFCA-XX*
	T-13A	XGOA-XX*	XGCA-XX*
2	T-3A	XCOA-XX*	XCCA-XX*
	T-5A	XDOA-XX*	XDCA-XX*
3	T-16A	XIOA-XX*	XICA-XX*
4	T-18A	XKOA-XX*	XKCA-XX*

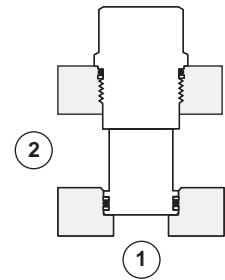

#### Plugs for Three Port Cavities

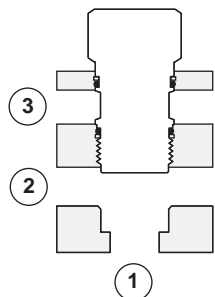

Series	Cavity	Ports 1 to 2 Open Port 3 Blocked	All Ports Blocked
		Cavity Plug Model Code	Cavity Plug Model Code
P	T-9A	XAOB-XX*	XACB-XX*
0	T-163A	XZOB-XX*	XZCB-XX*
1	T-11A	XEOA-XX*	XECA-XX*
2	T-2A	XBOA-XX*	XBCA-XX*
3	T-17A	XHOA-XX*	XHCA-XX*
4	T-19A	XJOA-XX*	XJCA-XX*

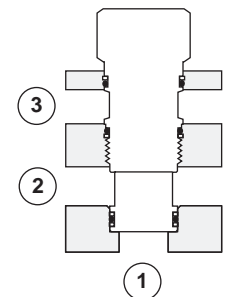

#### Plugs for Four Port Cavities (Internal Locating Shoulder)

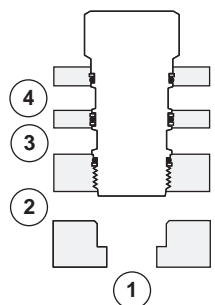

Series	Cavity	Ports 1 to 2 Open Port 3 and 4 Blocked	All Ports Blocked
		Cavity Plug Model Code	Cavity Plug Model Code
1	T-21A	XMOA-XX*	XMCA-XX*
2	T-22A	XNOA-XX*	XNCA-XX*
3	T-23A	XPOA-XX*	XPCA-XX*
4	T-24A	XQOA-XX*	XQCA-XX*

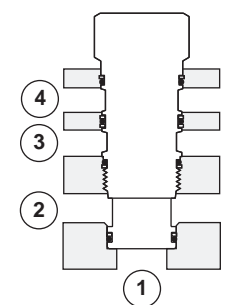

\*Insert in the seventh position model code digit N to order Buna-N seals or V to order Viton seals.

**CAVITY PLUGS**

**Plugs for Four Port Cavities (External Locating Shoulder)**

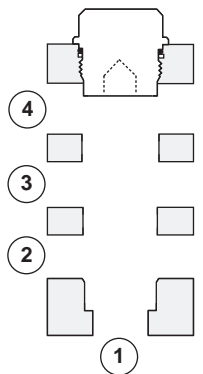

		All Ports Open	All Ports Blocked
Series	Cavity	Cavity Plug Model Code*	Cavity Plug Model Code*
1	T-31A	XFOA-XX*	XRCA-XX*
2	T-32A	XCOA-XX*	XSCA-XX*
3	T-33A	XIOA-XX*	XTCA-XX*
4	T-34A	XKOA-XX*	XVCA-XX*

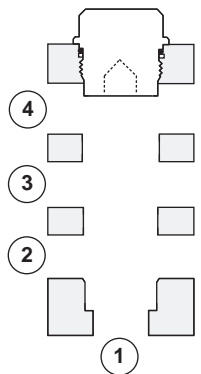

**Plugs for Six Port Cavities**

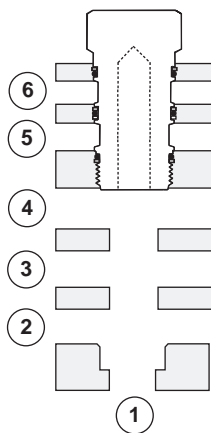

		Ports 1, 2, 3 and 4 Open Ports 5 and 6 Blocked	All Ports Blocked
Series	Cavity	Cavity Plug Model Code*	Cavity Plug Model Code*
1	T-61A	XMOA-XX*	XRCC-XX*
2	T-62A	XNOA-XX*	XSCC-XX*
3	T-63A	XPOA-XX*	XTCC-XX*
4	T-64A	XQOA-XX*	XVCC-XX*

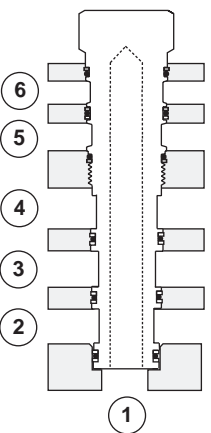

**Cavity Adaptor (Adapts Waterman 12-2 Cavity to the Sun T-8A Cavity)**

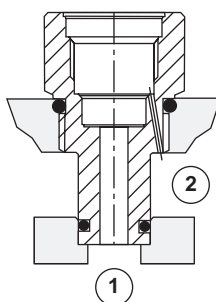

		All Ports Open
Cavity	Cavity Plug Model Code*	
12-2	XAAA-8X*	

\*Insert in the seventh position model code digit N to order Buna-N seals or V to order Viton seals.

**SOLENOID ELECTRICAL CONNECTOR OPTIONS**

**Pilot Flow Solenoid Valves: DAAA, DBAA**

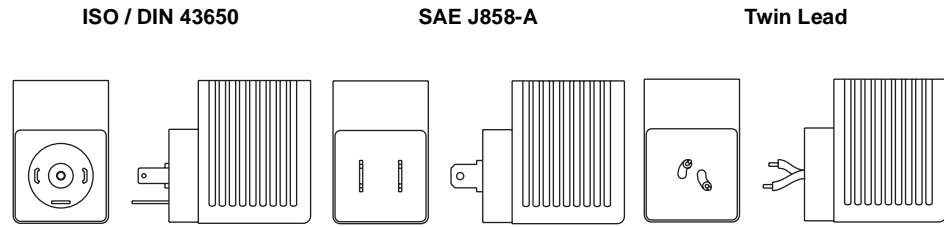

Description	Coil only part number		Coil only part number		Coil only part number	
115 V AC 50/60 Hz	760-211		N/A		N/A	
230 V AC 50/60 Hz	760-223		N/A		N/A	
6 V DC	760-206		760-506		N/A	
12 V DC	760-212		760-512		760-712	
24 V DC	760-224		760-524		760-724	
36 V DC	760-236		N/A		N/A	
48 V DC	760-248		N/A		N/A	

**Full Flow Solenoid Valves: DLDA, DTDA, DMDA, DNDA**

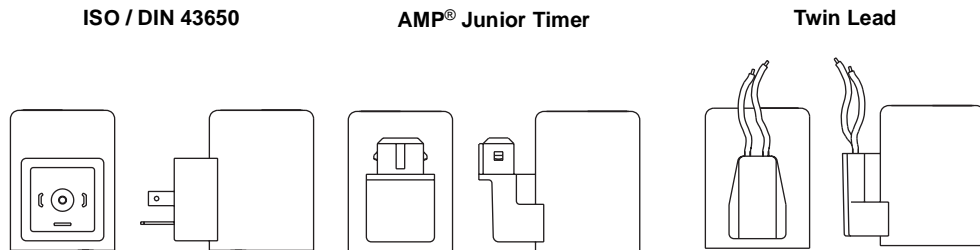

Description	Coil only part number		Coil only part number		Coil only part number	
115 V AC 50/60 Hz	770-211		N/A		N/A	
230 V AC 50/60 Hz	770-223		N/A		N/A	
12 V DC	770-212		770-612		770-712	
24 V DC	770-224		770-624		770-724	
48 V DC	770-248		770-648		770-748	

AMP® is a registered trademark.

**ORIFICE PRESSURE DROP DATA**

No allowance has been made for viscosity effects, or regain of pressure downstream.

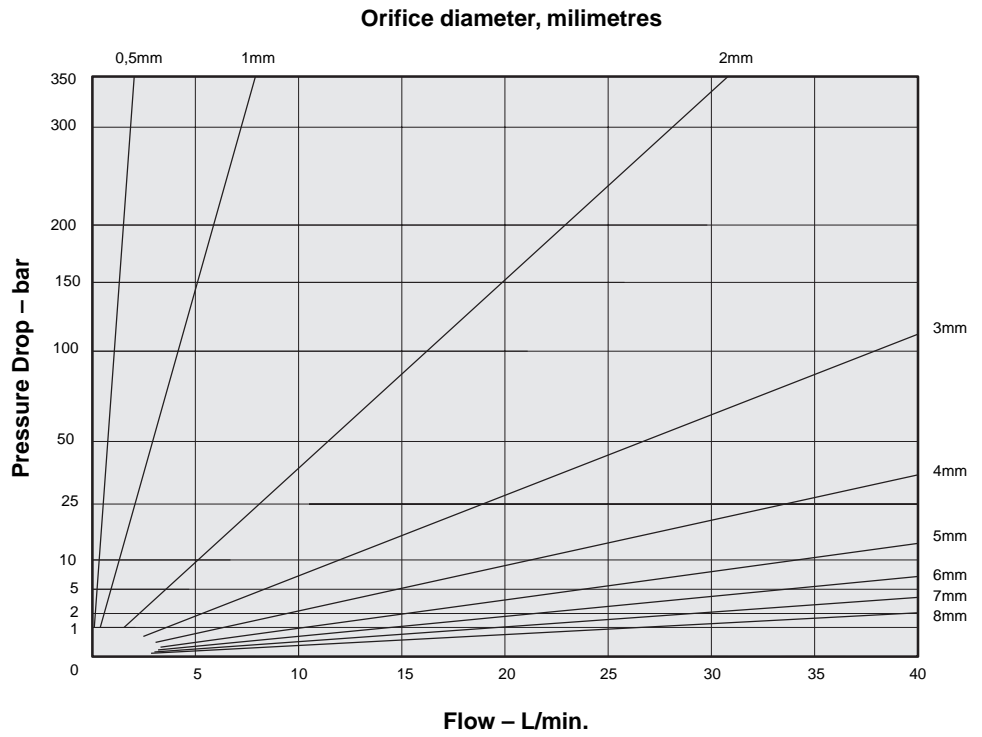

These charts are based on the formula:

$$Q = \alpha A \sqrt{\frac{2\Delta P}{\rho}}$$

Where:

- Q = Flow m<sup>3</sup>/sec.
- α = orifice coefficient
- A = orifice dia. cm<sup>2</sup>
- Δ P = pressure drop N/m<sup>2</sup>
- ρ = density Ns<sup>2</sup>/m<sup>4</sup>

This equation becomes:

$$Q \text{ (l,min)} = 0.4212 \times d^2 \text{ (mm)} \sqrt{\text{pressure drop (bar)}}$$

when c = 0.6  
ρ = 0.9 g/cm<sup>3</sup>

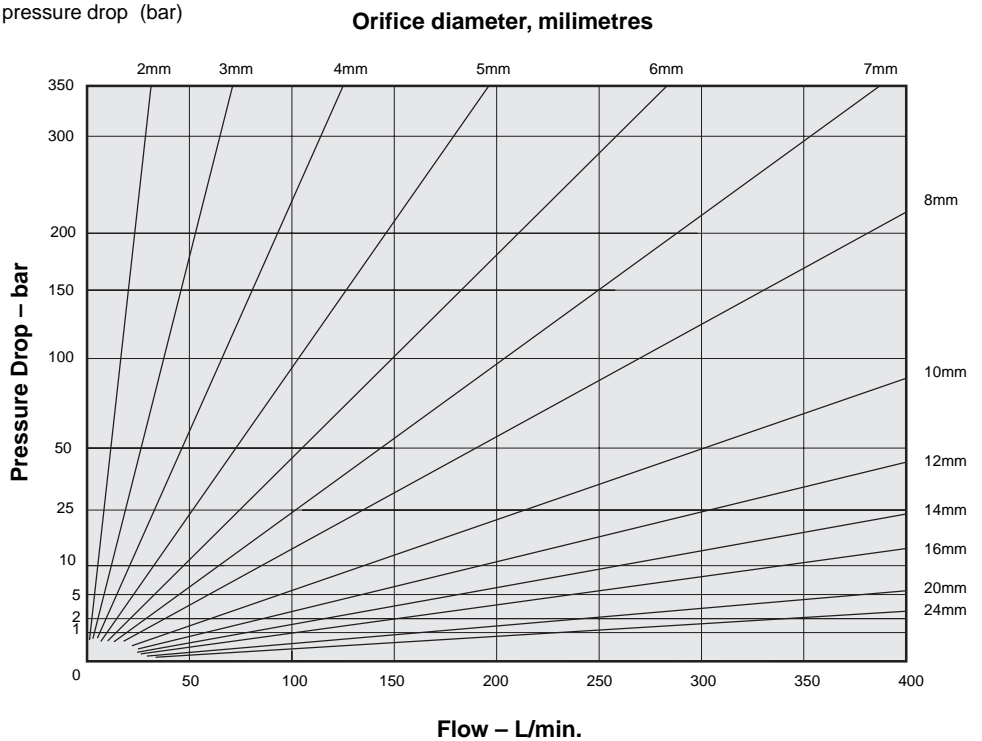

## General Information: Cartridge Cavities and Cavity Tools

**NOTES:** Thin wall deep hex sockets, preferred for installing Sun cartridges, are available from Sun or Snap-On Tools Corporation. Complete cavity machining dimensions are provided with form tools or supplied upon request. Dimensions shown below are simplified for manifold design purposes.

### SERIES P

#### T-8A 2 Port Sun Cavity

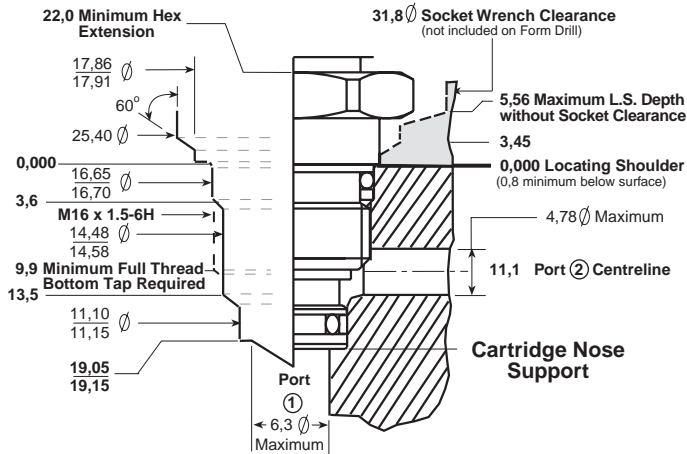

Cavity Diameters to be concentric to threads within 0,05.

© SUN Hydraulics Corporation

#### Minimum Clearance Distances:

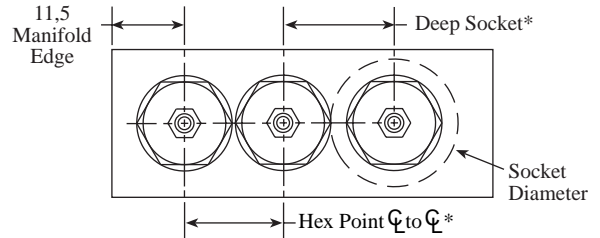

\* See respective Pilot Stage Cartridge Outline Drawing for Deep Socket and Hex Point clearance centreline dimensions

Description	High Speed Steel	Titanium Coated
	Model Code	Model Code
Form Drill TD-8A	994-008-001	994-008-101
Form Reamer TR-8A	995-008-001	995-008-101
Metric Tap M16x1.5-6H	998-991	998-991-101

Note: Drill and Reamer have a #3 Morse taper. Tap has straight shank.

#### 7/8" Hex Deep Socket:

Sun P/N: 998-100-006, Snap-On P/N: SIML280

#### T-9A 3 Port Sun Cavity

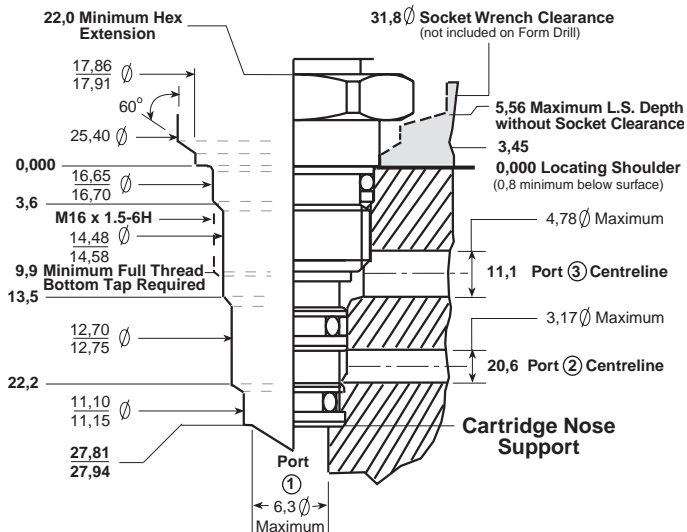

Cavity Diameters to be concentric to threads within 0,05.

© SUN Hydraulics Corporation

#### Minimum Clearance Distances:

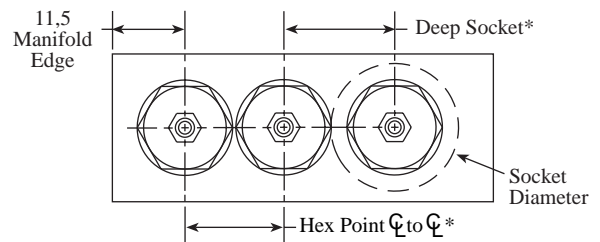

\* See respective Pilot Stage Cartridge Outline Drawing for Deep Socket and Hex Point clearance centreline dimensions.

Description	High Speed Steel	Titanium Coated
	Model Code	Model Code
Form Drill TD-9A	994-009-001	994-009-101
Form Reamer TR-9A	995-009-001	995-009-101
Metric Tap M16x1.5-6H	998-991	998-991-101

Note: Drill and Reamer have a #3 Morse taper. Tap has straight shank.

#### 7/8" Hex Deep Socket:

Sun P/N: 998-100-006, Snap-On P/N: SIML280



## General Information: Cartridge Cavities and Cavity Tools

**NOTES:** Thin wall deep hex sockets, preferred for installing Sun cartridges, are available from Sun or Snap-On Tools Corporation. Complete cavity machining dimensions are provided with form tools or supplied upon request. Dimensions shown below are simplified for manifold design purposes.

### SERIES 0

#### T-162A 2 Port Sun Cavity

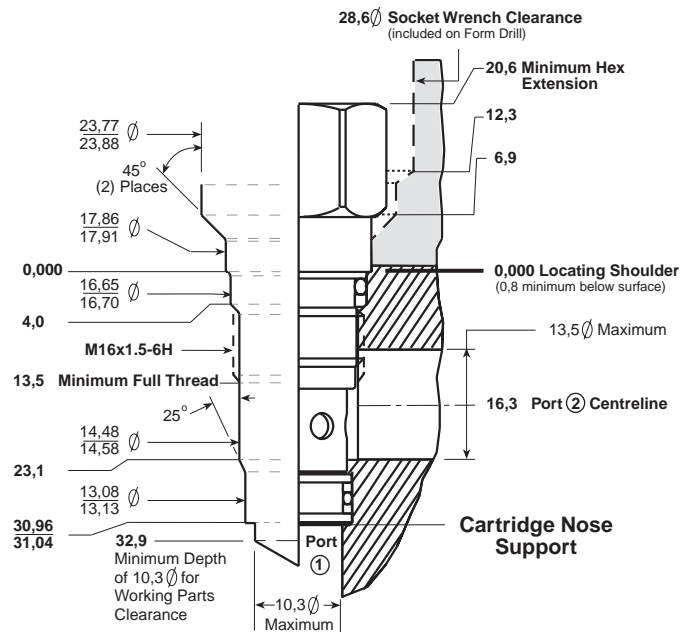

Cavity Diameters to be concentric to threads within 0,05.

© SUN Hydraulics Corporation

#### Minimum Clearance Distances:

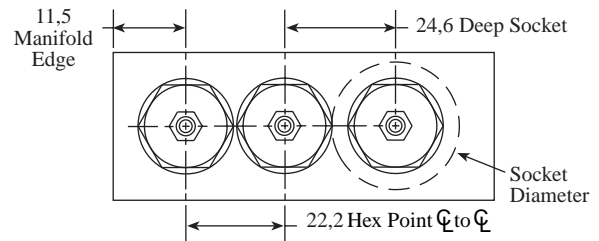

Description	High Speed Steel	Titanium Coated
	Model Code	Model Code
Form Drill TD-162A	994-162-001	994-162-101
Form Reamer TR-162A	995-162-001	995-162-101
Metric Tap M16x1.5-6H	998-991	998-991-101

Note: Drill and Reamer have a #3 Morse taper. Tap has straight shank.

#### 3/4" Hex Deep Socket:

Sun P/N: 998-100-005, Snap-On P/N: S241

#### T-163A 3 Port Sun Cavity

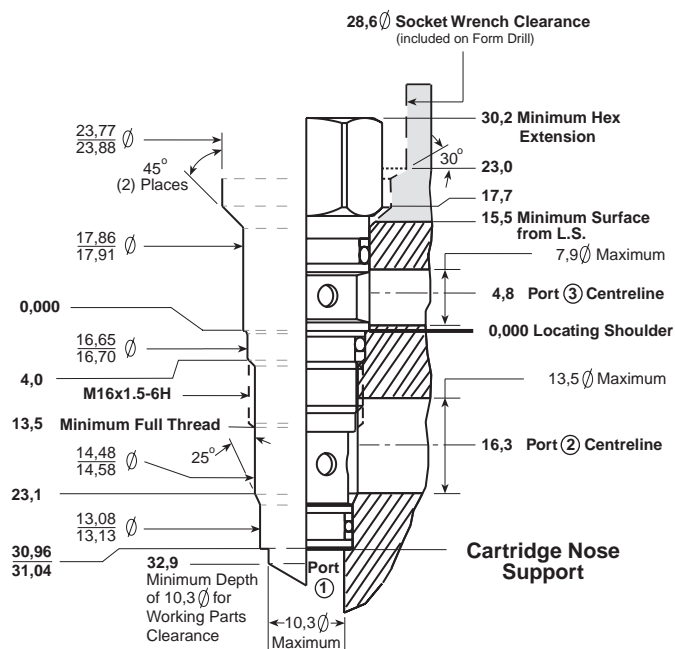

Cavity Diameters to be concentric to threads within 0,05.

© SUN Hydraulics Corporation

#### Minimum Clearance Distances:

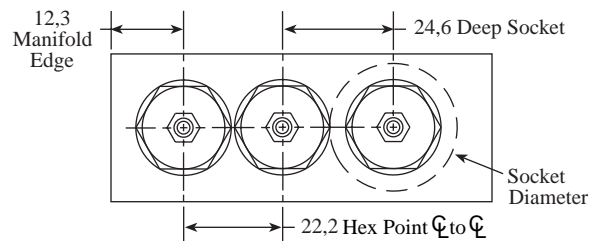

Description	High Speed Steel	Titanium Coated
	Model Code	Model Code
Form Drill TD-163A	994-163-001	994-163-101
Form Reamer TR-163A	995-163-001	995-163-101
Metric Tap M16x1.5-6H	998-991	998-991-101

Note: Drill and Reamer have a #3 Morse taper. Tap has straight shank.

#### 3/4" Hex Deep Socket:

Sun P/N: 998-100-005, Snap-On P/N: S241

## General Information: Cartridge Cavities and Cavity Tools

**NOTES:** Thin wall deep hex sockets, preferred for installing Sun cartridges, are available from Sun or Snap-On Tools Corporation. Complete cavity machining dimensions are provided with form tools or supplied upon request. Dimensions shown below are simplified for manifold design purposes.

### SERIES 1

#### T-10A 2 Port Sun Cavity

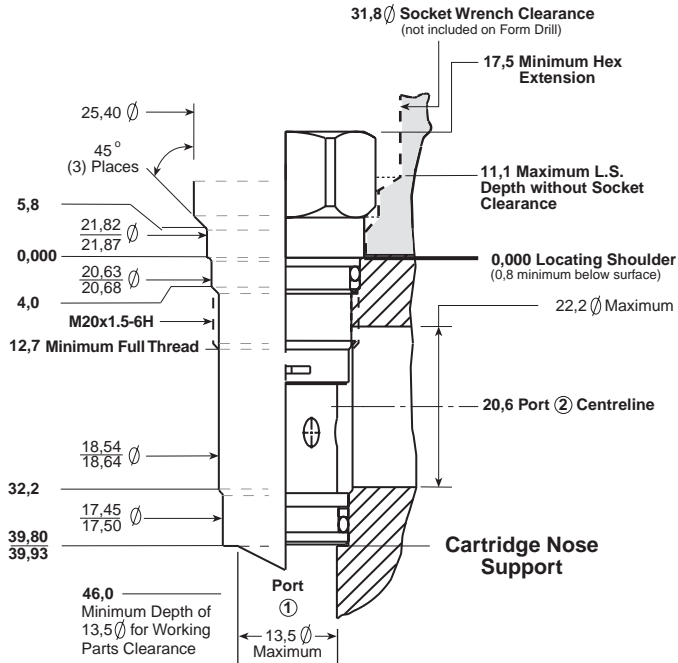

Cavity Diameters to be concentric to threads within 0,05.

© SUN Hydraulics Corporation

#### Minimum Clearance Distances:

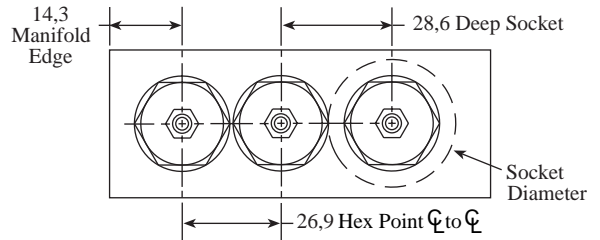

Description	High Speed Steel	Titanium Coated
	Model Code	Model Code
Form Drill TD-10A	994-010-001	994-010-101
Form Reamer TR-10A	995-010-001	995-010-101
Metric Tap M20x1.5-6H	998-998	998-998-101

Note: Drill and Reamer have a #3 Morse taper. Tap has straight shank.

#### 7/8" Hex Deep Socket:

Sun P/N: 998-100-001, Snap-On P/N: S281

#### T-13A 2 Port Sun Cavity

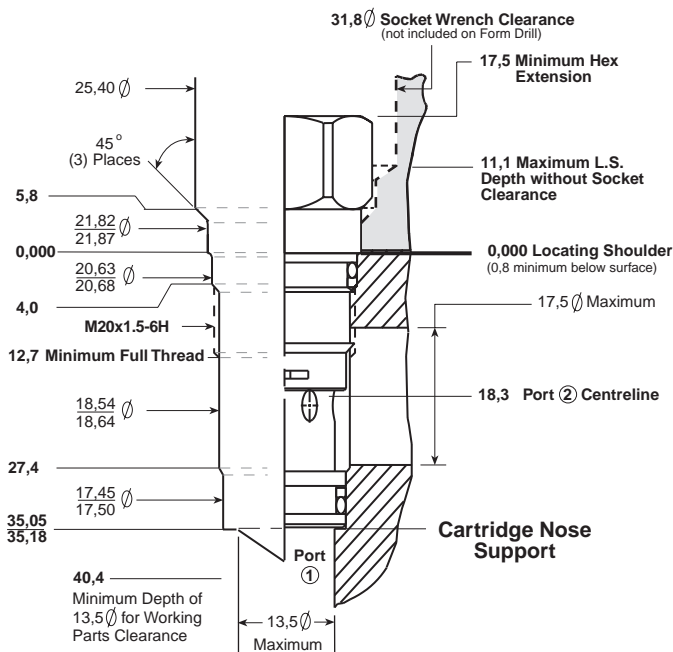

Cavity Diameters to be concentric to threads within 0,05.

© SUN Hydraulics Corporation

#### Minimum Clearance Distances:

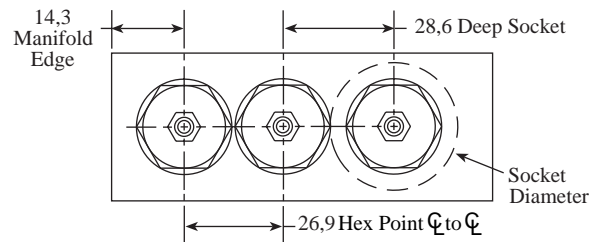

Description	High Speed Steel	Titanium Coated
	Model Code	Model Code
Form Drill TD-13A	994-013-001	994-013-101
Form Reamer TR-13A	995-013-001	995-013-101
Metric Tap M20x1.5-6H	998-998	998-998-101

Note: Drill and Reamer have a #3 Morse taper. Tap has straight shank.

#### 7/8" Hex Deep Socket:

Sun P/N: 998-100-001, Snap-On P/N: S281

## General Information: Cartridge Cavities and Cavity Tools

**NOTES:** Thin wall deep hex sockets, preferred for installing Sun cartridges, are available from Sun or Snap-On Tools Corporation. Complete cavity machining dimensions are provided with form tools or supplied upon request. Dimensions shown below are simplified for manifold design purposes.

### SERIES 1

#### T-11A 3 Port Sun Cavity

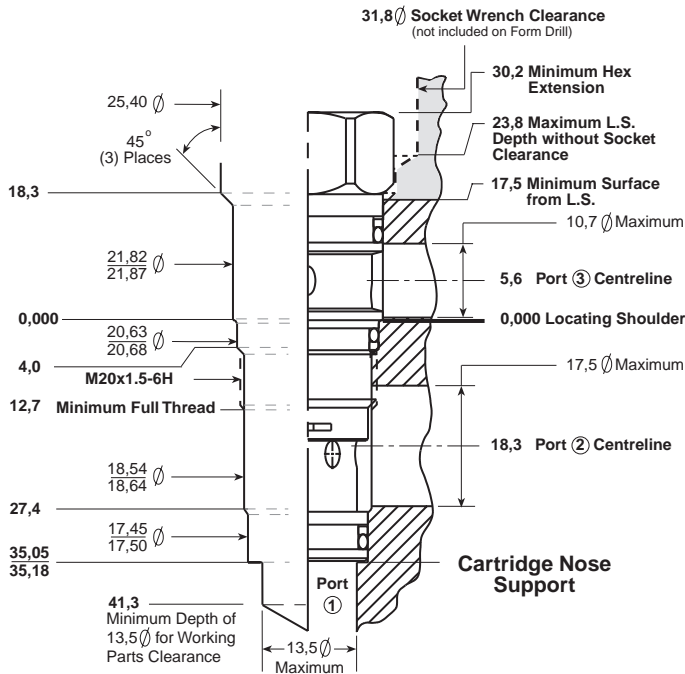

Cavity Diameters to be concentric to threads within 0,05.

© SUN Hydraulics Corporation

#### Minimum Clearance Distances:

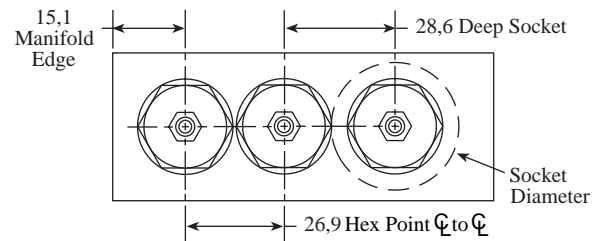

Description	High Speed Steel	Titanium Coated
	Model Code	Model Code
Form Drill TD-11A	994-011-001	994-011-101
Form Reamer TR-11A	995-011-001	995-011-101
Metric Tap M20x1.5-6H	998-998	998-998-101

Note: Drill and Reamer have a #3 Morse taper. Tap has straight shank.

#### 7/8" Hex Deep Socket:

Sun P/N: 998-100-001, Snap-On P/N: S281

#### T-21A 4 Port Sun Cavity

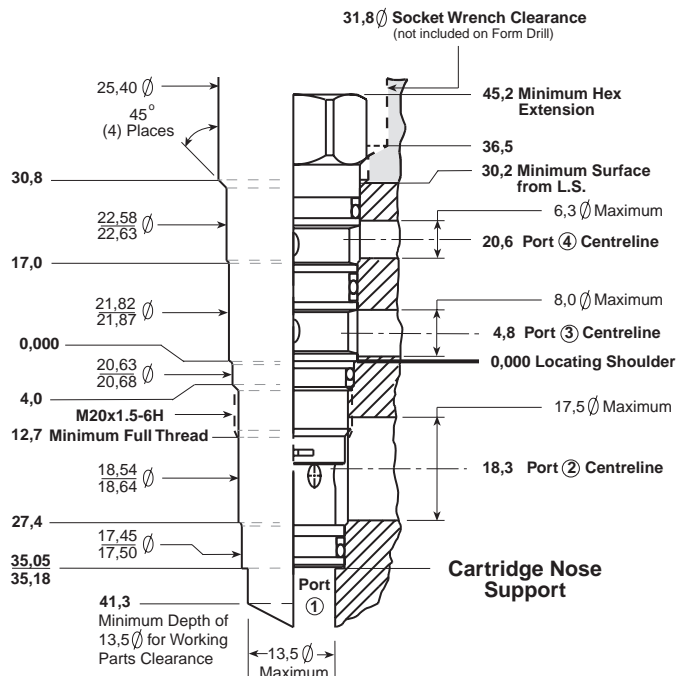

Cavity Diameters to be concentric to threads within 0,05.

© SUN Hydraulics Corporation

#### Minimum Clearance Distances:

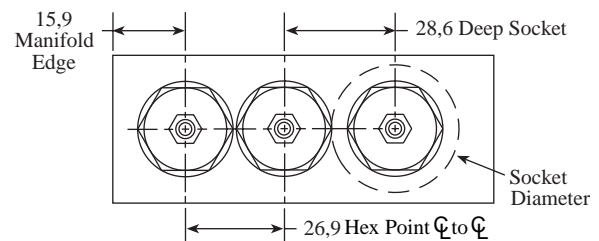

Description	High Speed Steel	Titanium Coated
	Model Code	Model Code
Form Drill TD-21A	994-021-001	994-021-101
Form Reamer TR-21A	995-021-001	995-021-101
Metric Tap M20x1.5-6H	998-998	998-998-101

Note: Drill and Reamer have a #3 Morse taper. Tap has straight shank.

#### 7/8" Hex Deep Socket:

Sun P/N: 998-100-001, Snap-On P/N: S281

## General Information: Cartridge Cavities and Cavity Tools

**NOTES:** Thin wall deep hex sockets, preferred for installing Sun cartridges, are available from Sun or Snap-On Tools Corporation. Complete cavity machining dimensions are provided with form tools or supplied upon request. Dimensions shown below are simplified for manifold design purposes.

### SERIES 1

#### T-31A 4 Port Sun Cavity

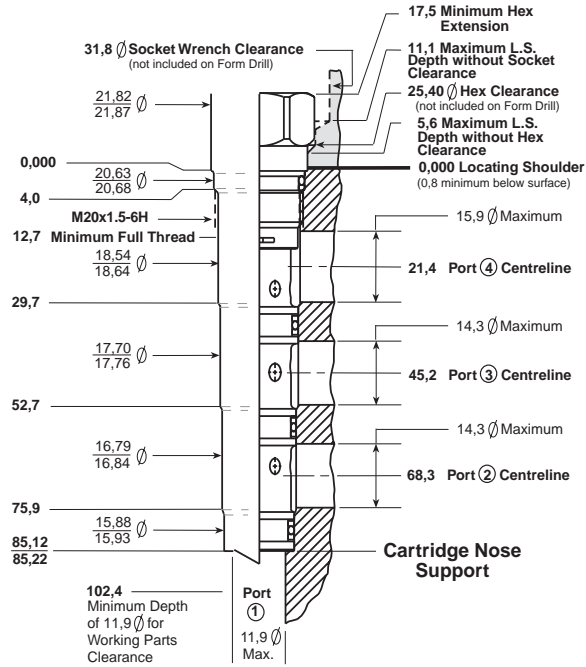

Cavity Diameters to be concentric to threads within 0,05.

© SUN Hydraulics Corporation

#### Minimum Clearance Distances:

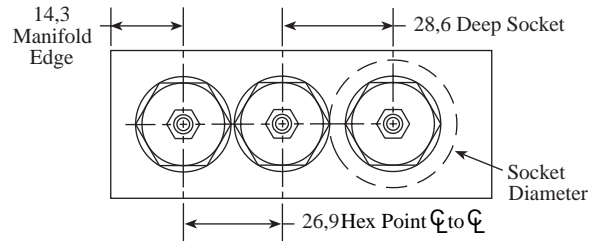

Description	High Speed Steel	Titanium Coated
	Model Code	Model Code
Form Drill TD-31A	994-031-001	994-031-101
Form Reamer TR-31A	995-031-001	995-031-101
Metric Tap M20x1.5-6H	998-998	998-998-101

Note: Drill and Reamer have a #3 Morse taper. Tap has straight shank.

#### 7/8" Hex Deep Socket:

Sun P/N: 998-100-001, Snap-On P/N: S281

#### T-61A 6 Port Sun Cavity

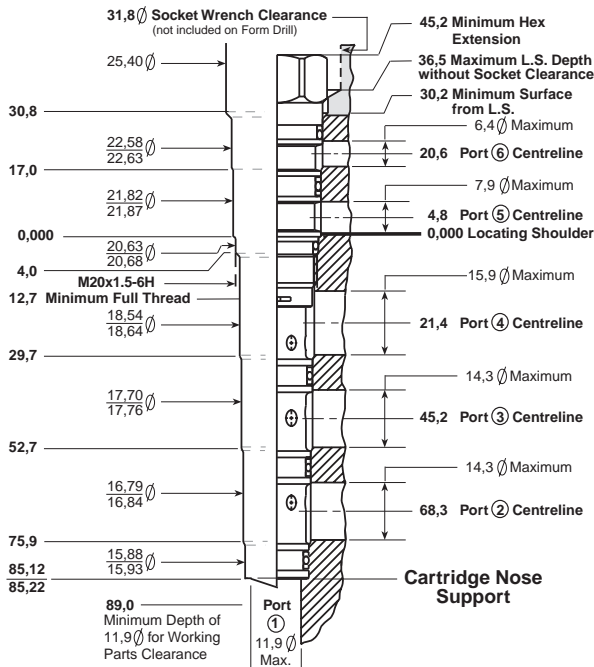

Cavity Diameters to be concentric to threads within 0,05.

© SUN Hydraulics Corporation

#### Minimum Clearance Distances:

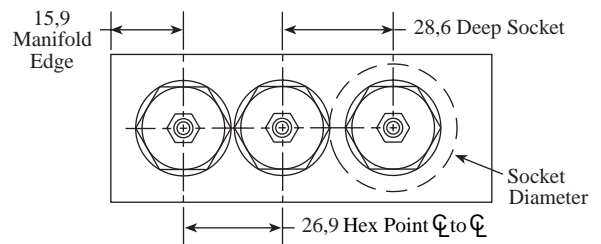

Description	High Speed Steel	Titanium Coated
	Model Code	Model Code
Form Drill TD-61A	994-061-001	994-061-101
Form Reamer TR-61A	995-061-001	995-061-101
Metric Tap M20x1.5-6H	998-998	998-998-101

Note: Drill and Reamer have a #3 Morse taper. Tap has straight shank.

#### 7/8" Hex Deep Socket:

Sun P/N: 998-100-001, Snap-On P/N: S281

## General Information: Cartridge Cavities and Cavity Tools

**NOTES:** Thin wall deep hex sockets, preferred for installing Sun cartridges, are available from Sun or Snap-On Tools Corporation. Complete cavity machining dimensions are provided with form tools or supplied upon request. Dimensions shown below are simplified for manifold design purposes.

### SERIES 2

#### T-3A 2 Port Sun Cavity

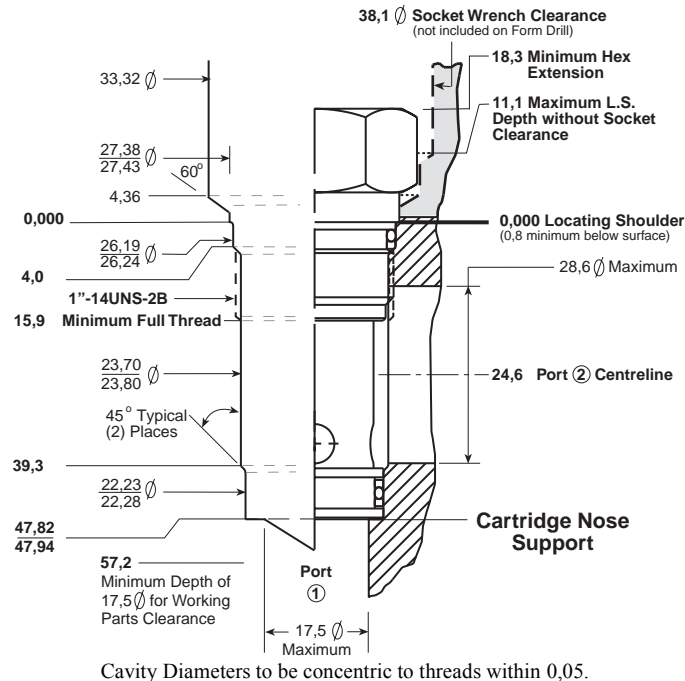

#### Minimum Clearance Distances:

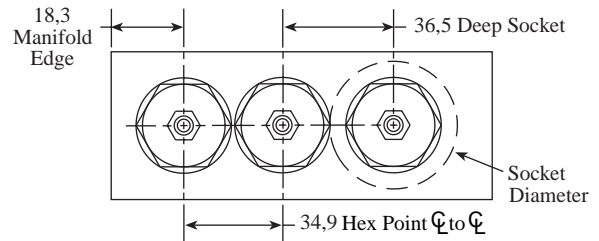

Description	High Speed Steel	Titanium Coated
	Model Code	Model Code
Form Drill TD-3A	994-003-001	994-003-101
Form Reamer TR-3A	995-003-001	995-003-101
UNS Tap 1"-14	998-999	998-999-101

Note: Drill and Reamer have a #3 Morse taper. Tap has straight shank.

#### 1 1/8" Hex Deep Socket:

Sun P/N: 998-100-002, Snap-On P/N: S361

#### T-5A 2 Port Sun Cavity

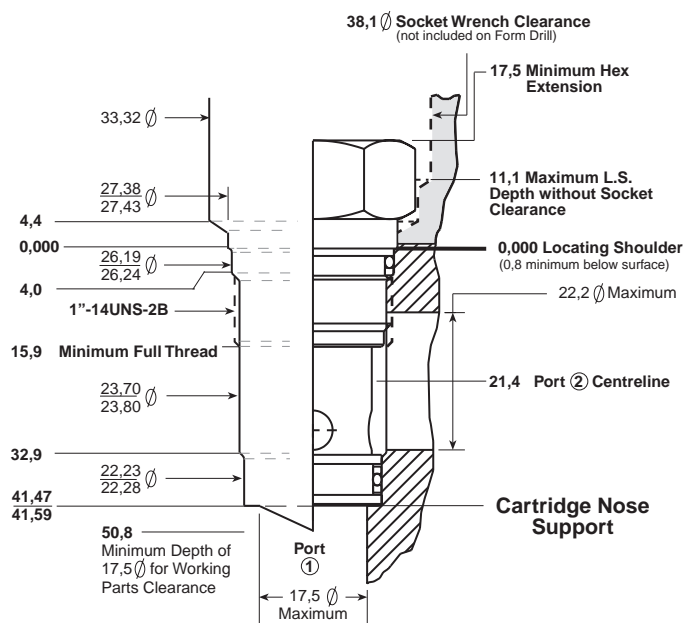

#### Minimum Clearance Distances:

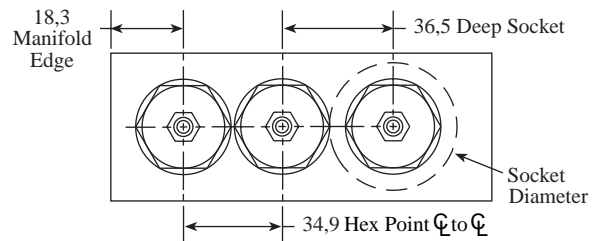

Description	High Speed Steel	Titanium Coated
	Model Code	Model Code
Form Drill TD-5A	994-005-001	994-005-101
Form Reamer TR-5A	995-005-001	995-005-101
UNS Tap 1"-14	998-999	998-999-101

Note: Drill and Reamer have a #3 Morse taper. Tap has straight shank.

#### 1 1/8" Hex Deep Socket:

Sun P/N: 998-100-002, Snap-On P/N: S361

## General Information: Cartridge Cavities and Cavity Tools

**NOTES:** Thin wall deep hex sockets, preferred for installing Sun cartridges, are available from Sun or Snap-On Tools Corporation. Complete cavity machining dimensions are provided with form tools or supplied upon request. Dimensions shown below are simplified for manifold design purposes.

### SERIES 2

#### T-2A 3 Port Sun Cavity

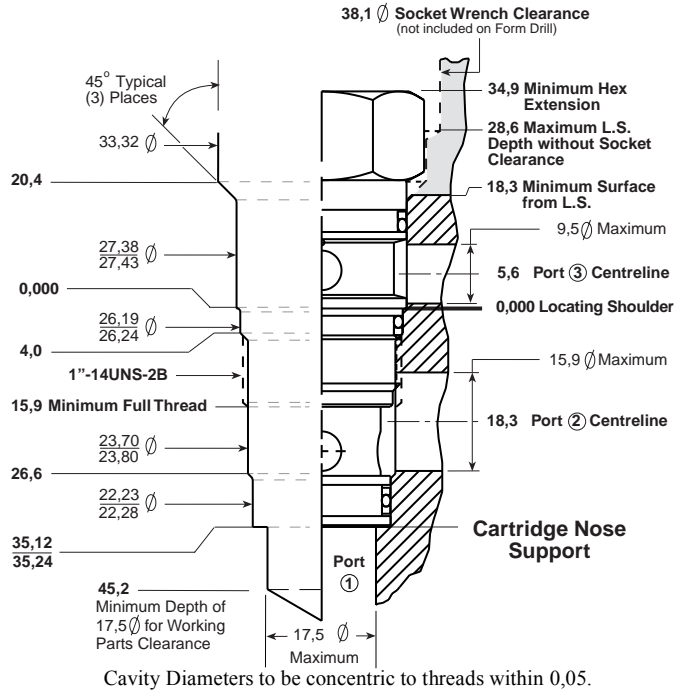

#### Minimum Clearance Distances:

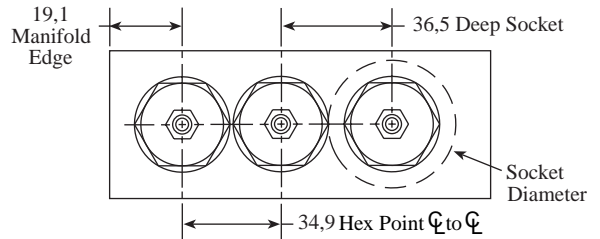

Description	High Speed Steel	Titanium Coated
	Model Code	Model Code
Form Drill TD-2A	994-002-001	994-002-101
Form Reamer TR-2A	995-002-001	995-002-101
UNS Tap 1"-14	998-999	998-999-101

Note: Drill and Reamer have a #3 Morse taper. Tap has straight shank.

#### 1 1/8" Hex Deep Socket:

Sun P/N: 998-100-002, Snap-On P/N: S361

#### T-22A 4 Port Sun Cavity

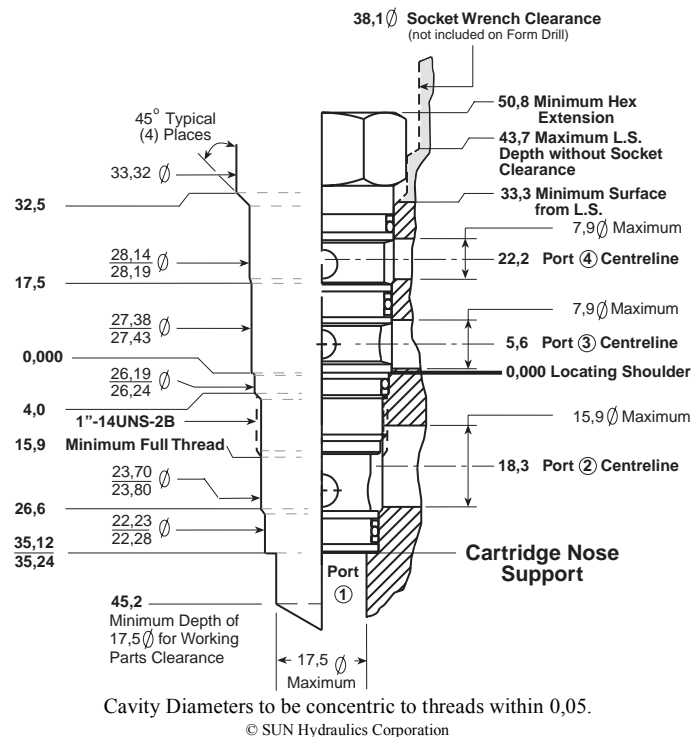

#### Minimum Clearance Distances:

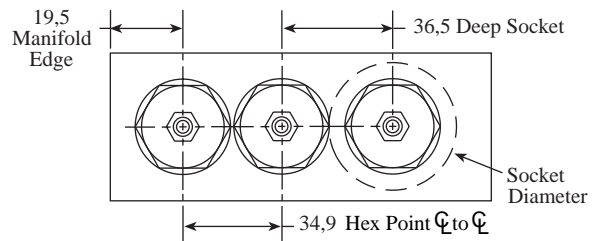

Description	High Speed Steel	Titanium Coated
	Model Code	Model Code
Form Drill TD-22A	994-022-001	994-022-101
Form Reamer TR-22A	995-022-001	995-022-101
UNS Tap 1"-14	998-999	998-999-101

Note: Drill and Reamer have a #3 Morse taper. Tap has straight shank.

#### 1 1/8" Hex Deep Socket:

Sun P/N: 998-100-002, Snap-On P/N: S361

## General Information: Cartridge Cavities and Cavity Tools

**NOTES:** Thin wall deep hex sockets, preferred for installing Sun cartridges, are available from Sun or Snap-On Tools Corporation. Complete cavity machining dimensions are provided with form tools or supplied upon request. Dimensions shown below are simplified for manifold design purposes.

### SERIES 2

#### T-32A 4 Port Sun Cavity

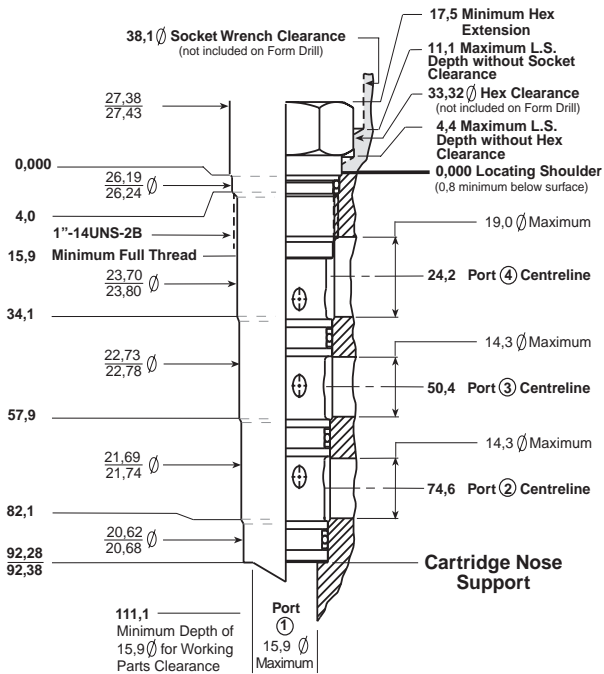

Cavity Diameters to be concentric to threads within 0,05.

© SUN Hydraulics Corporation

#### Minimum Clearance Distances:

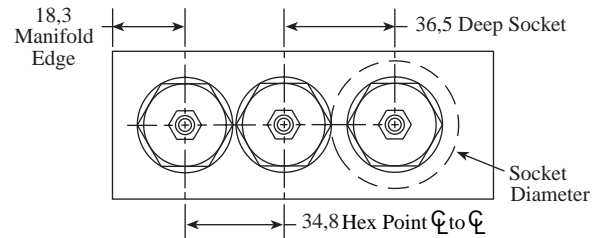

Description	High Speed Steel	Titanium Coated
	Model Code	Model Code
Form Drill TD-32A	994-032-001	994-032-101
Form Reamer TR-32A	995-032-001	995-032-101
UNS Tap 1"-14UNS-2B	998-999	998-999-101

Note: Drill and Reamer have a #3 Morse taper. Tap has straight shank.

#### 1 1/8" Hex Deep Socket:

Sun P/N: 998-100-002, Snap-On P/N: S361

#### T-62A 6 Port Sun Cavity

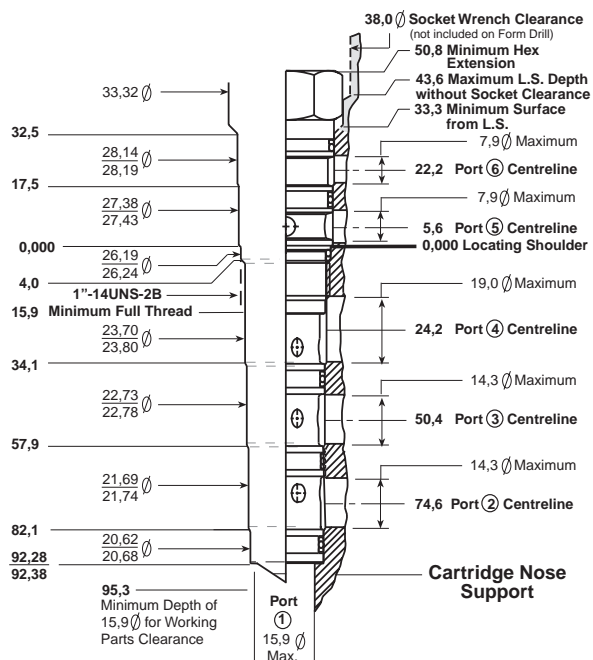

Cavity Diameters to be concentric to threads within 0,05.

© SUN Hydraulics Corporation

#### Minimum Clearance Distances:

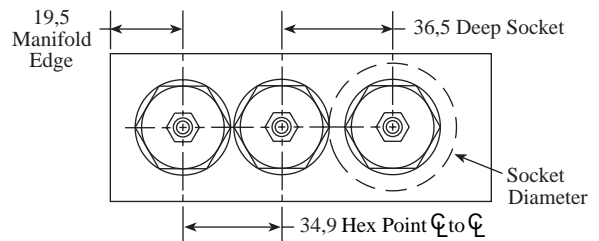

Description	High Speed Steel	Titanium Coated
	Model Code	Model Code
Form Drill TD-62A	994-062-001	994-062-101
Form Reamer TR-62A	995-062-001	995-062-101
UNS Tap 1"-14UNS-2B	998-999	998-999-101

Note: Drill and Reamer have a #3 Morse taper. Tap has straight shank.

#### 1 1/8" Hex Deep Socket:

Sun P/N: 998-100-002, Snap-On P/N: S361

## General Information: Cartridge Cavities and Cavity Tools

**NOTES:** Thin wall deep hex sockets, preferred for installing Sun cartridges, are available from Sun or Snap-On Tools Corporation. Complete cavity machining dimensions are provided with form tools or supplied upon request. Dimensions shown below are simplified for manifold design purposes.

### SERIES 3

#### T-16A 2 Port Sun Cavity

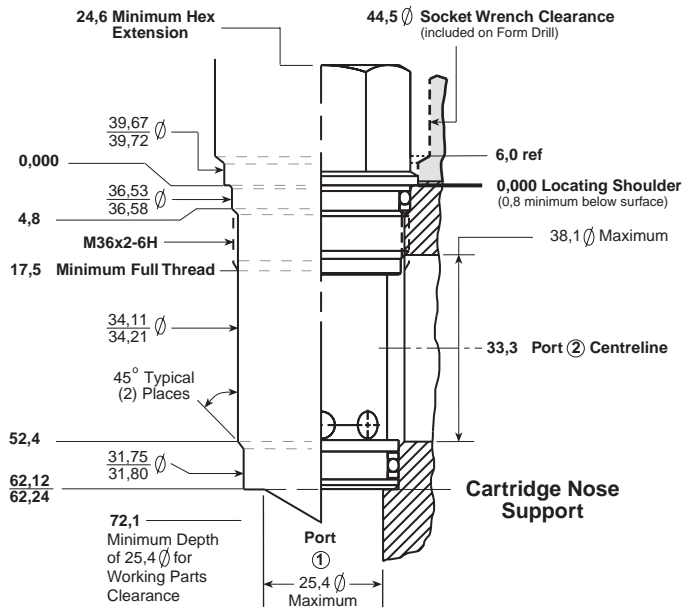

Cavity Diameters to be concentric to threads within 0,05.

© SUN Hydraulics Corporation

#### Minimum Clearance Distances:

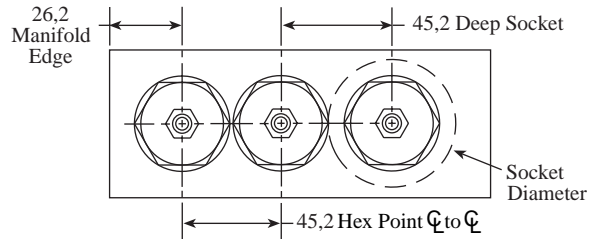

Description	High Speed Steel	Titanium Coated
	Model Code	Model Code
Form Drill TD-16A	994-016-001	994-016-101
Form Reamer TR-16A	995-016-001	995-016-101
Metric Tap M36x2-6H	998-996	998-996-101

Note: Drill and Reamer have a #3 Morse taper. Tap has straight shank.

#### 1 1/4" Hex Deep Socket:

Sun P/N: 998-100-003, Snap-On P/N: S401

#### T-17A 3 Port Sun Cavity

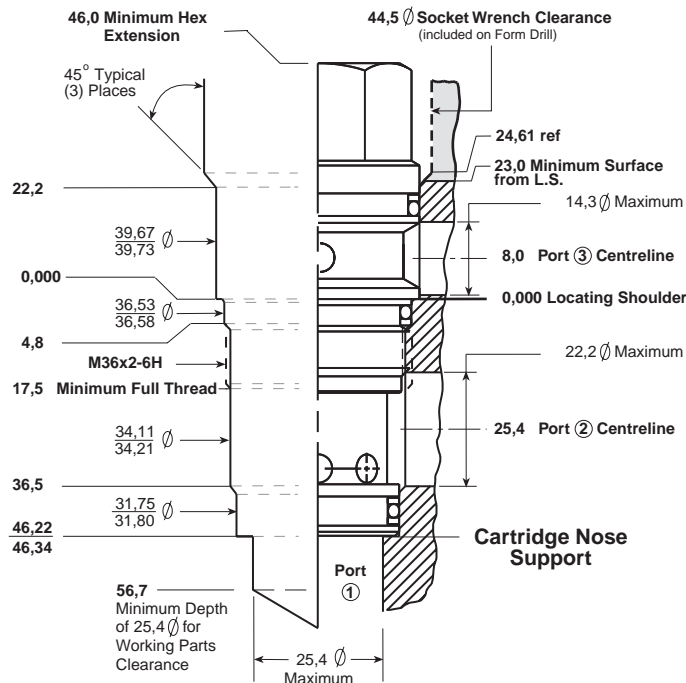

Cavity Diameters to be concentric to threads within 0,05.

© SUN Hydraulics Corporation

#### Minimum Clearance Distances:

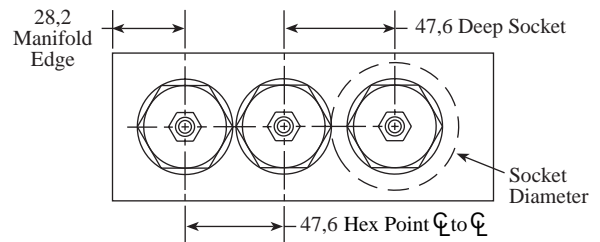

Description	High Speed Steel	Titanium Coated
	Model Code	Model Code
Form Drill TD-17A	994-017-001	994-017-101
Form Reamer TR-17A	995-017-001	995-017-101
Metric Tap M36x2-6H	998-996	998-996-101

Note: Drill and Reamer have a #3 Morse taper. Tap has straight shank.

#### 1 1/4" Hex Deep Socket:

Sun P/N: 998-100-003, Snap-On P/N: S401



## General Information: Cartridge Cavities and Cavity Tools

**NOTES:** Thin wall deep hex sockets, preferred for installing Sun cartridges, are available from Sun or Snap-On Tools Corporation. Complete cavity machining dimensions are provided with form tools or supplied upon request. Dimensions shown below are simplified for manifold design purposes.

### SERIES 3

#### T-23A 4 Port Sun Cavity

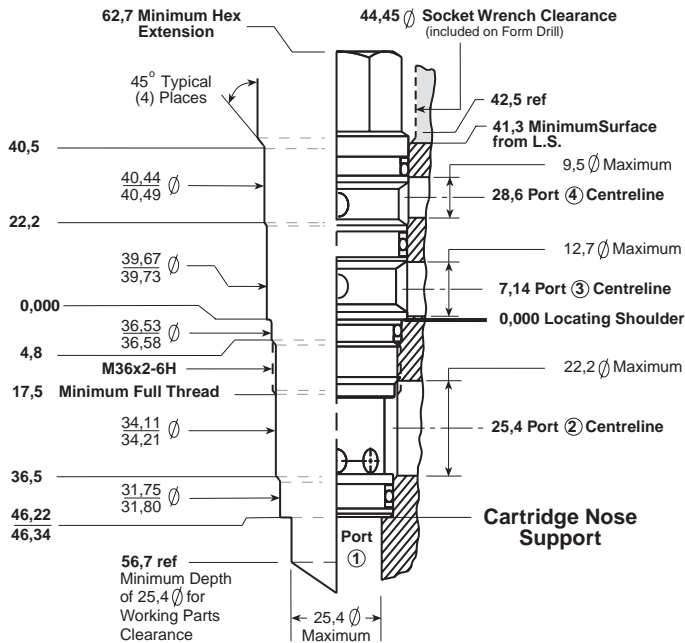

Cavity Diameters to be concentric to threads within 0,05.

© SUN Hydraulics Corporation

#### Minimum Clearance Distances:

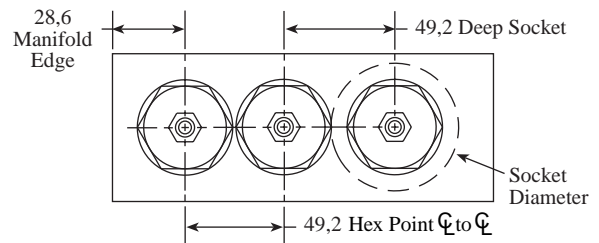

Description	High Speed Steel	Titanium Coated
	Model Code	Model Code
Form Drill TD-23A	994-023-001	994-023-101
Form Reamer TR-23A	995-023-001	995-023-101
Metric Tap M36x2-6H	998-996	998-996-101

Note: Drill and Reamer have a #3 Morse taper. Tap has straight shank.

#### 1 1/4" Hex Deep Socket:

Sun P/N: 998-100-003, Snap-On P/N: S401

#### T-33A 4 Port Sun Cavity

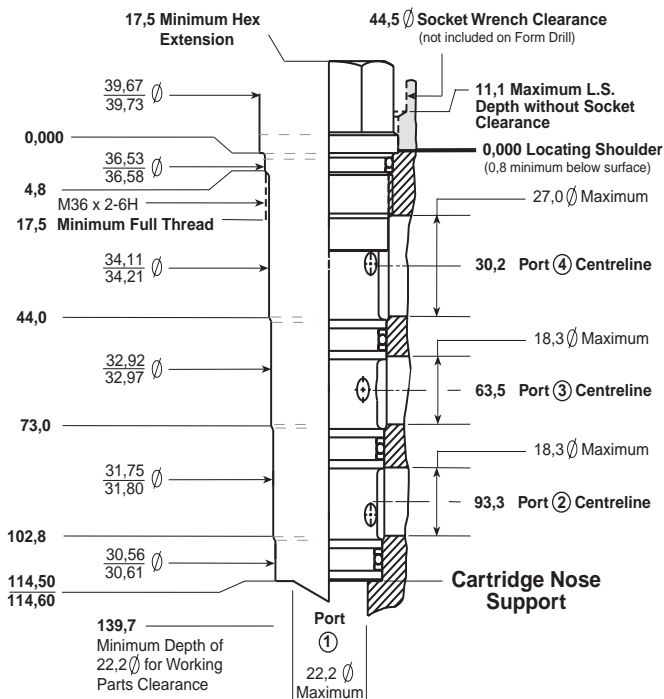

Cavity Diameters to be concentric to threads within 0,05.

© SUN Hydraulics Corporation

#### Minimum Clearance Distances:

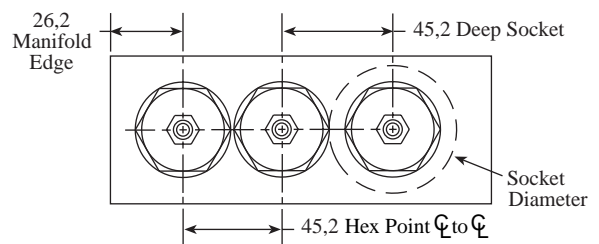

Description	High Speed Steel	Titanium Coated
	Model Code	Model Code
Form Drill TD-33A	994-033-001	994-033-101
Form Reamer TR-33A	995-033-001	995-033-101
Metric Tap M36x2-6H	998-996	998-996-101

Note: Drill and Reamer have a #3 Morse taper. Tap has straight shank.

#### 1 1/4" Hex Deep Socket:

Sun P/N: 998-100-003, Snap-On P/N: S401

## General Information: Cartridge Cavities and Cavity Tools

**NOTES:** Thin wall deep hex sockets, preferred for installing Sun cartridges, are available from Sun or Snap-On Tools Corporation. Complete cavity machining dimensions are provided with form tools or supplied upon request. Dimensions shown below are simplified for manifold design purposes.

### SERIES 3

#### T-63A 6 Port Sun Cavity

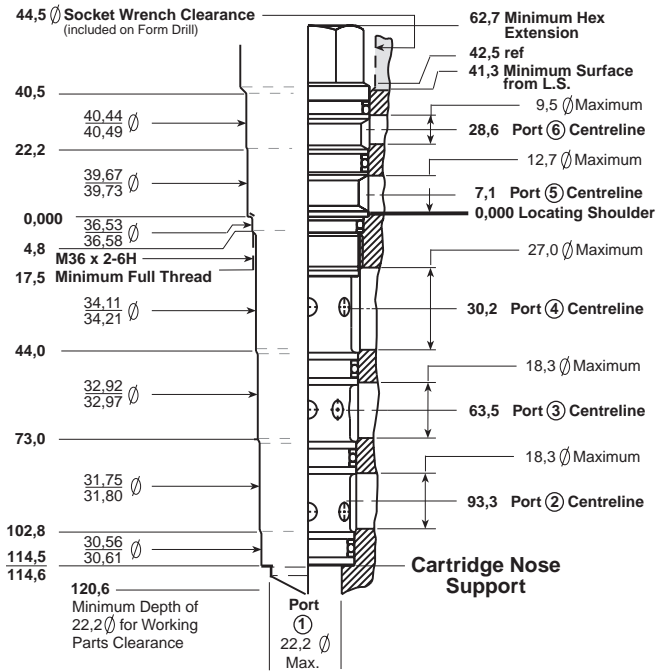

Cavity Diameters to be concentric to threads within 0,05.

© SUN Hydraulics Corporation

#### Minimum Clearance Distances:

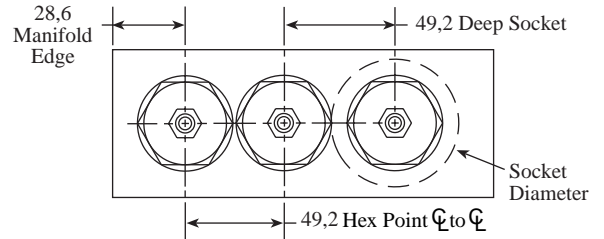

Description	High Speed Steel	Titanium Coated
	Model Code	Model Code
Form Drill TD-63A	994-063-001	994-063-101
Form Reamer TR-63A	995-063-001	995-063-101
Metric Tap M36x2-6H	998-996	998-996-101

Note: Drill and Reamer have a #3 Morse taper. Tap has straight shank.

#### 1 1/4" Hex Deep Socket:

Sun P/N: 998-100-003, Snap-On P/N: S401

## General Information: Cartridge Cavities and Cavity Tools

**NOTES:** Thin wall deep hex sockets, preferred for installing Sun cartridges, are available from Sun or Snap-On Tools Corporation. Complete cavity machining dimensions are provided with form tools or supplied upon request. Dimensions shown below are simplified for manifold design purposes.

### SERIES 4

#### T-18A 2 Port Sun Cavity

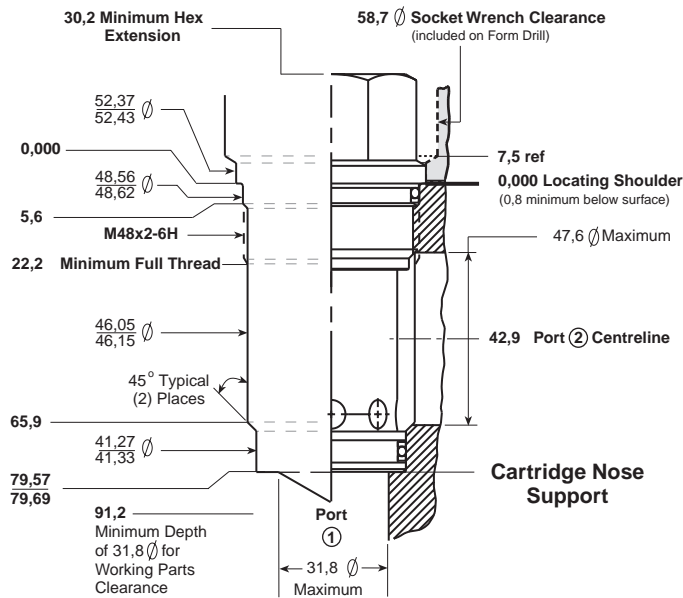

Cavity Diameters to be concentric to threads within 0,05.

© SUN Hydraulics Corporation

#### Minimum Clearance Distances:

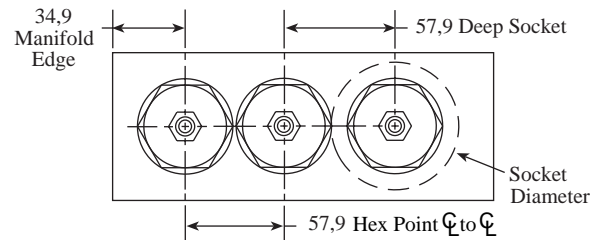

Description	High Speed Steel	Titanium Coated
	Model Code	Model Code
Form Drill TD-18A	994-018-001	994-018-101
Form Reamer TR-18A	995-018-001	995-018-101
Metric Tap M48x2-6H	998-992	998-992-101

Note: Drill and Reamer have a #3 Morse taper. Tap has straight shank.

#### 1 5/8" Hex Deep Socket:

Sun P/N: 998-100-004, Snap-On P/N: LS522

#### T-19A 3 Port Sun Cavity

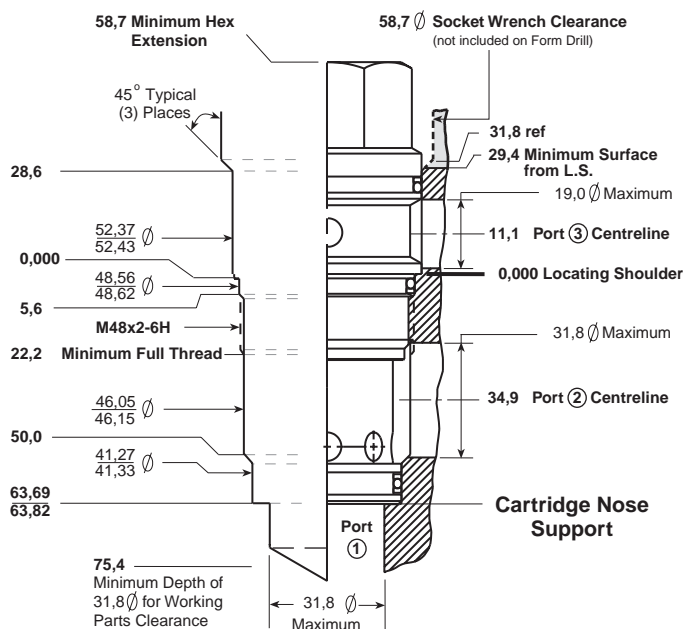

Cavity Diameters to be concentric to threads within 0,05.

© SUN Hydraulics Corporation

#### Minimum Clearance Distances:

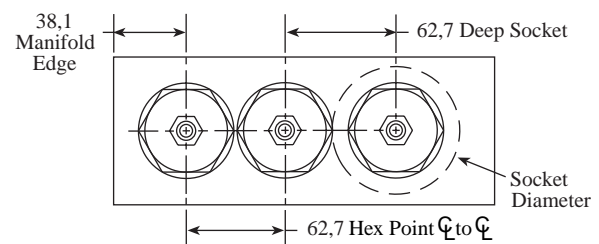

Description	High Speed Steel	Titanium Coated
	Model Code	Model Code
Form Drill TD-19A	994-019-001	994-019-101
Form Reamer TR-19A	995-019-001	995-019-101
Metric Tap M48x2-6H	998-992	998-992-101

Note: Drill and Reamer have a #3 Morse taper. Tap has straight shank.

#### 1 5/8" Hex Deep Socket:

Sun P/N: 998-100-004, Snap-On P/N: LS522

## General Information: Cartridge Cavities and Cavity Tools

**NOTES:** Thin wall deep hex sockets, preferred for installing Sun cartridges, are available from Sun or Snap-On Tools Corporation. Complete cavity machining dimensions are provided with form tools or supplied upon request. Dimensions shown below are simplified for manifold design purposes.

### SERIES 4

#### T-24A 4 Port Sun Cavity

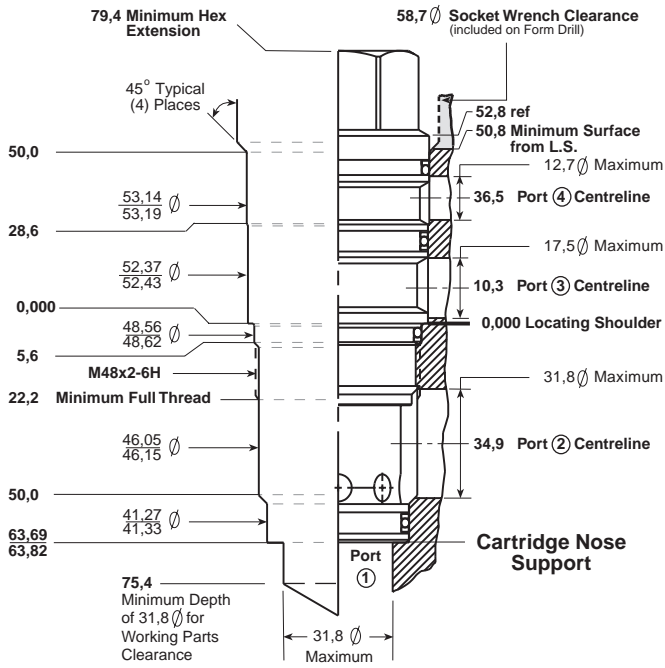

Cavity Diameters to be concentric to threads within 0,05.

© SUN Hydraulics Corporation

#### Minimum Clearance Distances:

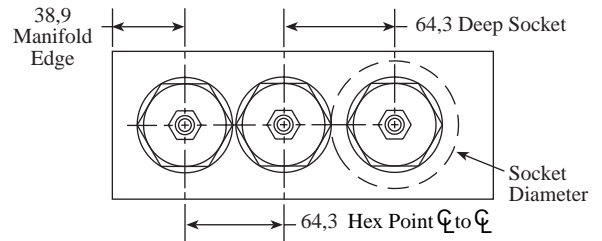

Description	High Speed Steel	Titanium Coated
	Model Code	Model Code
Form Drill TD-24A	994-024-001	994-024-101
Form Reamer TR-24A	995-024-001	995-024-101
Metric Tap M48x2-6H	998-992	998-992-101

Note: Drill and Reamer have a #3 Morse taper. Tap has straight shank.

#### 1 5/8" Hex Deep Socket:

Sun P/N: 998-100-004, Snap-On P/N: LS522

#### T-34A 4 Port Sun Cavity

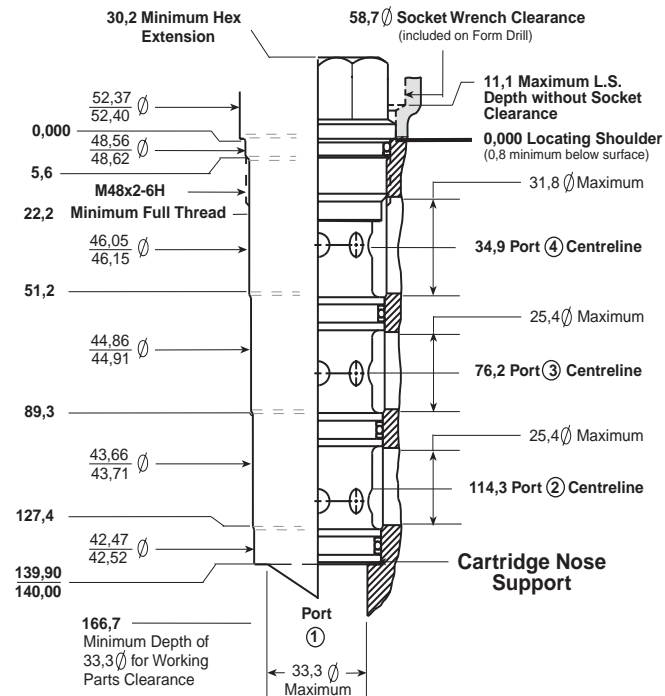

Cavity Diameters to be concentric to threads within 0,05.

© SUN Hydraulics Corporation

#### Minimum Clearance Distances:

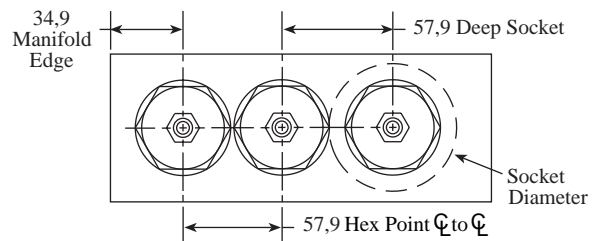

Description	High Speed Steel	Titanium Coated
	Model Code	Model Code
Form Drill TD-34A	994-034-001	994-034-101
Form Reamer TR-34A	995-034-001	995-034-101
Metric Tap M48x2-6H	998-992	998-992-101

Note: Drill and Reamer have a #3 Morse taper. Tap has straight shank.

#### 1 5/8" Hex Deep Socket:

Sun P/N: 998-100-004, Snap-On P/N: LS522

## General Information: Cartridge Cavities and Cavity Tools

NOTES: Thin wall deep hex sockets, preferred for installing Sun cartridges, are available from Sun or Snap-On Tools Corporation. Complete cavity machining dimensions are provided with form tools or supplied upon request. Dimensions shown below are simplified for manifold design purposes.

### SERIES 4

#### T-64A 6 Port Sun Cavity

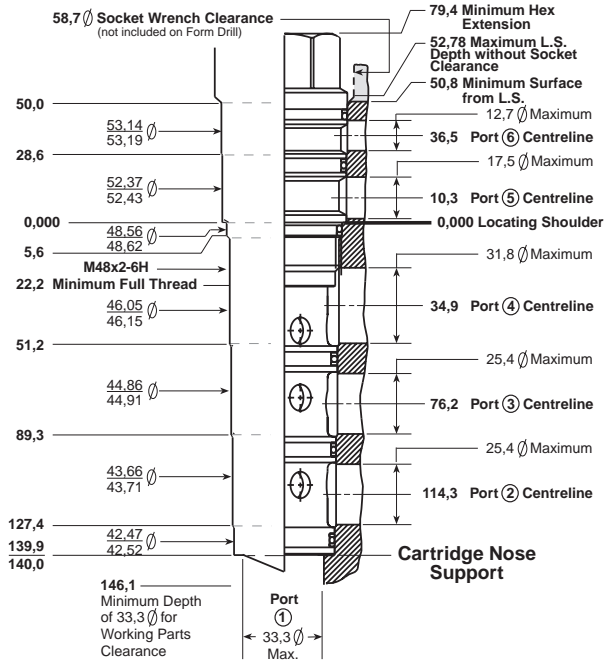

© SUN Hydraulics Corporation

#### Minimum Clearance Distances:

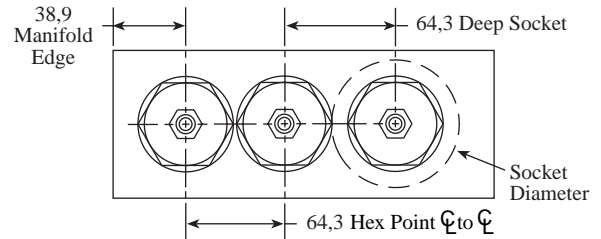

Description	High Speed Steel	Titanium Coated
	Model Code	Model Code
Form Drill TD-64A	994-064-001	994-064-101
Form Reamer TR-64A	995-064-001	995-064-101
Metric Tap M48x2-6H	998-992	998-992-101

Note: Drill and Reamer have a #3 Morse taper. Tap has straight shank.

#### 1 5/8" Hex Deep Socket:

Sun P/N: 999-100-004, Snap-On P/N: LS522