

**TECHNICAL PRODUCT INFORMATION**  
**HYDROSTATIC TRANSMISSION VALVES AND HOT OIL SHUTTLES**

**Applications**

In all closed loop hydrostatic transmission circuits it is necessary to remove and replace some of the oil from the circuit to provide cooling and filtration. The normal rule of thumb is to continuously take out 10-15% of the pump flow. This is achieved using a hot oil shuttle valve with low-pressure relief.

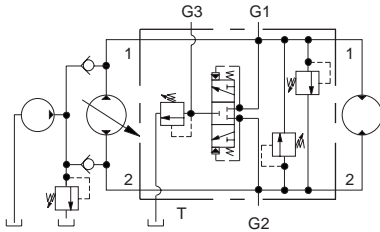

The hot oil shuttle valve senses pressure from the high-pressure side and opens to bleed off oil from the return low-pressure side of the circuit. A low-pressure charge pump into the inlet of the transmission pump makes up this oil.

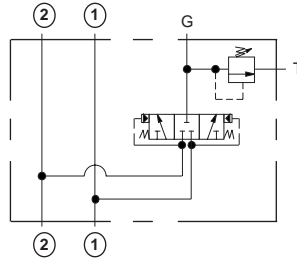

The oil passed through the hot oil shuttle valve goes across a low-pressure relief valve set at a slightly lower pressure than the charge pump. This oil is taken through an offline filtration and cooling unit before being returned to the oil reservoir. Often this oil is also passed through the casing drain of the transmission motor to help keep the motor cool.

The other main requirement for close loop circuits is cross line relief valves to provide protection from over pressurization to the pump and motor.

**Design Concepts and Features**

Sun offers a complete range of hot oil shuttle valves and hydrostatic transmission valves incorporating four through ports for easy installation into the circuit. The use of cartridge valves in these packages means an elimination of pipe work and provides easy maintenance. In the event of a problem, it simply means replacing a cartridge rather than the complete valve assembly. This reduces cost and eliminates down time. The cross line relief valves used are fast acting with limited overshoot to provide excellent protection from over pressurization.

Sun can provide packages to handle transmission flows from 40 L/min. right up to 960 L/min. and pressures up to 350 bar. As well as the standard packages shown in the catalogue, Sun can also design a custom package to suit the exact requirement for a customer's application.

# Standard Assemblies: Hydrostatic Transmission Valves and Hot Oil Shuttles

## HOT OIL SHUTTLE AND RELIEF APPLICATIONS (INLINE / 1.00" SAE FLANGE PORT BODIES)

### PILOT OPERATED

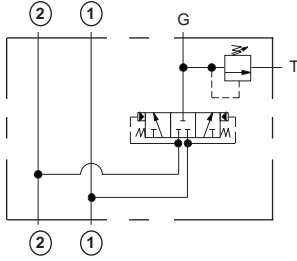

Ports 1 and 2	Port T	Assembly Model Code*
1/2" BSPP	3/8" BSPP	XRDC-LNN-AV
3/4" BSPP	3/8" BSPP	XRDC-LNN-AW

\*Add modifier /S to order SG Iron for pressure rating over 210 bar.

### 0-50 L/min. Cavity T-10A

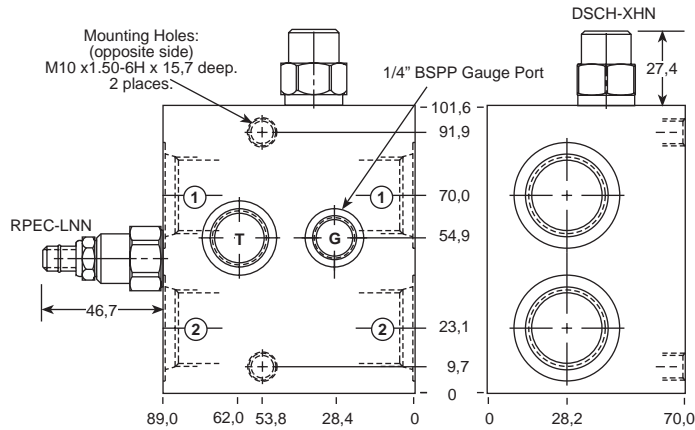

These Sun valve assemblies are for use in bleeding hot oil from the low pressure side of a hydrostatic transmission circuit. The hot oil can be cooled, filtered, or used as a source of oil for flushing other pump and motor cases. The hot oil is removed from the loop when the Sun RPEC cartridge is set below the hydrostatic charge pressure relief valve.

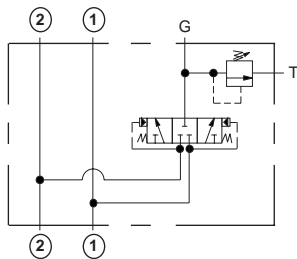
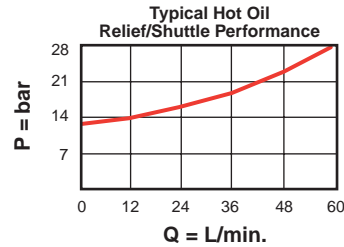

Ports 1 and 2	Port T	Assembly Model Code*
3/4" BSPP	1/2" BSPP	XRFC-LNN-AW

\*Add modifier /T to order SG Iron for pressure rating over 210 bar.

### 0-95 L/min. Cavity T-10A

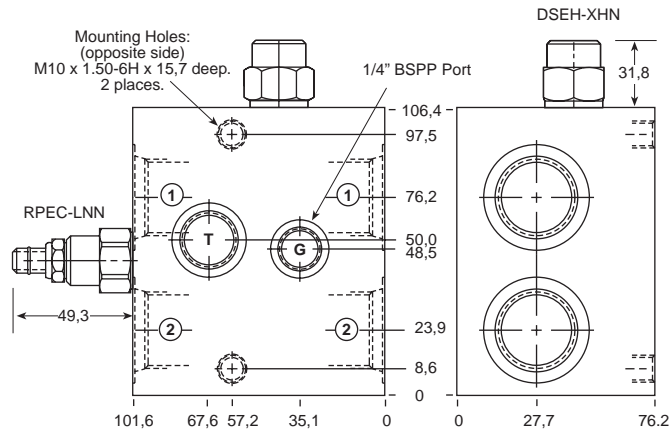

These Sun valve assemblies are for use in bleeding hot oil from the low pressure side of a hydrostatic transmission circuit. The hot oil can be cooled, filtered, or used as a source of oil for flushing other pump and motor cases. The hot oil is removed from the loop when the Sun RPEC cartridge is set below the hydrostatic charge pressure relief valve.

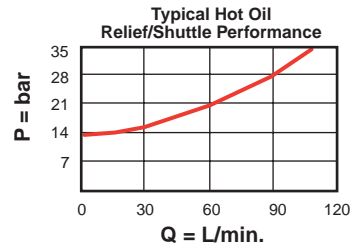

NOTES: Page 2 for cartridge model RP\*C-\*\*\* shows performance curves, technical tips, and options.  
See page vii for technical information about line mount bodies including SAE flange pattern specifications.  
Consult the Sun Factory for other port sizes available in the bodies shown above.  
Go to [www.sunhydraulics.com](http://www.sunhydraulics.com) for more product information.

**HOT OIL SHUTTLE AND RELIEF APPLICATIONS  
(INLINE BODIES)**

**PILOT OPERATED**

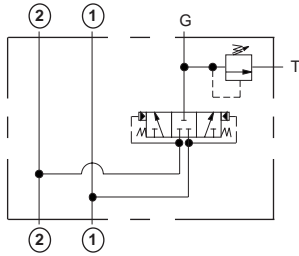

**0-200 L/min. Cavity T-3A**

Ports 1 and 2	Port T	Assembly Model Code*
1" BSPP	3/4" BSPP	XRHC-LNN-AX

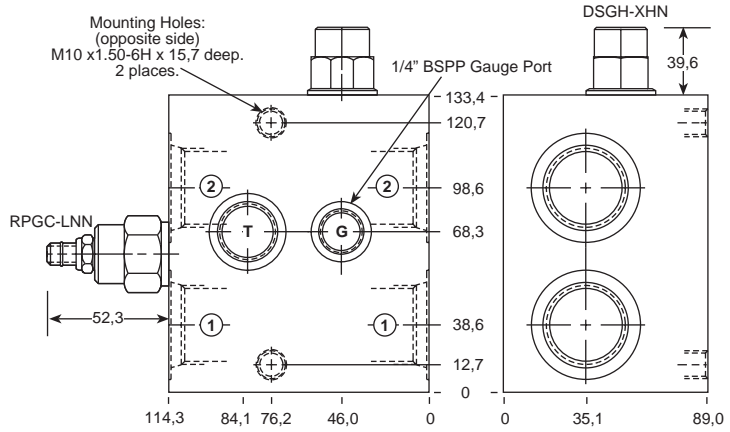

\*Add modifier /S to order SG Iron for pressure rating over 210 bar.

These Sun valve assemblies are for use in bleeding hot oil from the low pressure side of a hydrostatic transmission circuit. The hot oil can be cooled, filtered, or used as a source of oil for flushing other pump and motor cases. The hot oil is removed from the loop when the Sun RPGC cartridge is set below the hydrostatic charge pressure relief valve.

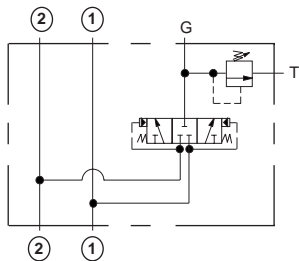
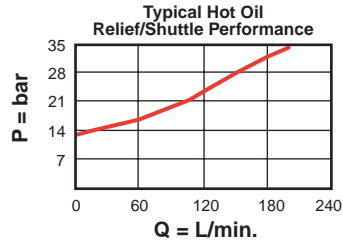

**0-380 L/min. Cavity T-16A**

Ports 1 and 2	Port T	Assembly Model Code*
1 1/4" BSPP	1" BSPP	XRJC-LNN-AX

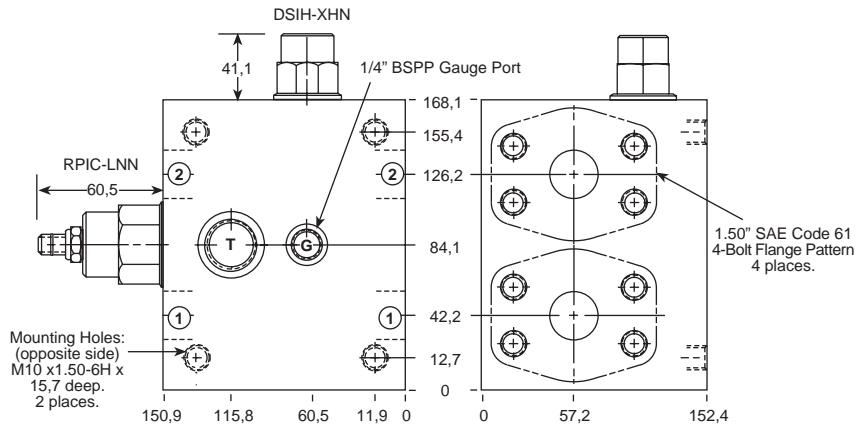

\*Add modifier /S to order SG Iron for pressure rating over 210 bar.

These Sun valve assemblies are for use in bleeding hot oil from the low pressure side of a hydrostatic transmission circuit. The hot oil can be cooled, filtered, or used as a source of oil for flushing other pump and motor cases. The hot oil is removed from the loop when the Sun RPIC cartridge is set below the hydrostatic charge pressure relief valve.

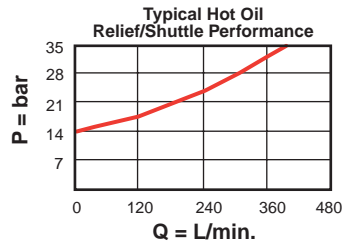

NOTES: Page 2 for cartridge model RP\*C-\*\*\* shows performance curves, technical tips, and options.  
See page vii for technical information about line mount bodies including SAE flange pattern specifications.  
Consult the Sun Factory for other port sizes available in the bodies shown above.  
Go to [www.sunhydraulics.com](http://www.sunhydraulics.com) for more product information.

**Standard Assemblies: Hydrostatic Transmission Valves and Hot Oil Shuttles**

**HOT OIL SHUTTLE AND RELIEF APPLICATIONS  
(1.50" SAE FLANGE PORT BODIES)**

**PILOT OPERATED**

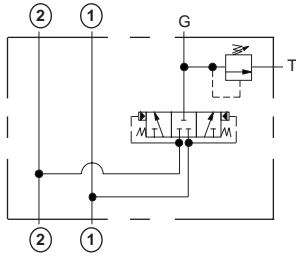

Ports 1 and 2	Port T	Assembly Model Code*
1 1/2" SAE C61	1" BSPP	<b>XRJC-LNN-AR/M</b>

\*Add modifier **/T** to order SG Iron for pressure rating over 210 bar.

**0-380 L/min. Cavity T-16A**

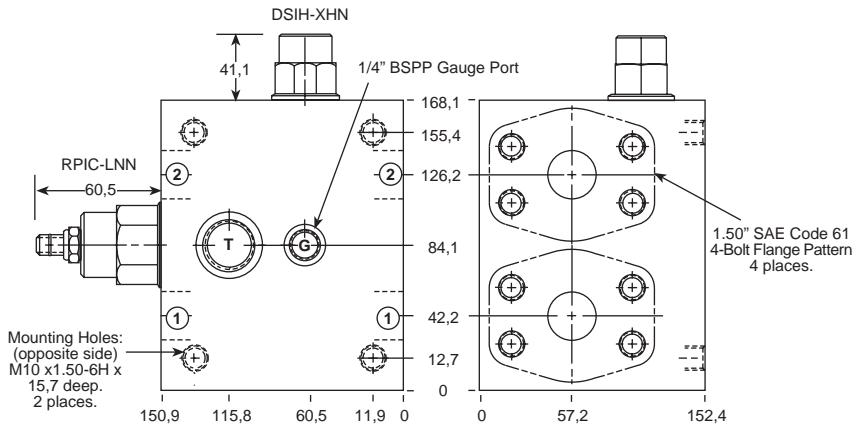

These Sun valve assemblies are for use in bleeding hot oil from the low pressure side of a hydrostatic transmission circuit. The hot oil can be cooled, filtered, or used as a source of oil for flushing other pump and motor cases. The hot oil is removed from the loop when the Sun RPIC cartridge is set below the hydrostatic charge pressure relief valve.

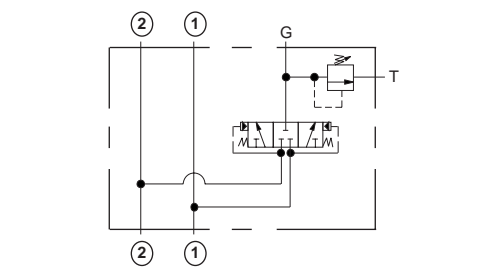
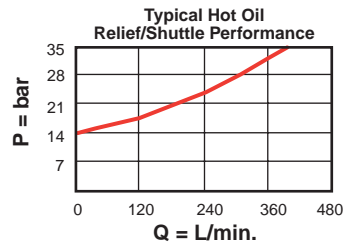

Ports 1 and 2	Port T	Assembly Model Code*
1 1/2" SAE C62	1" BSPP	<b>XRJC-LNN-A6/M</b>

\*Add modifier **/T** to order SG Iron for pressure rating over 210 bar.

**0-380 L/min. Cavity T-16A**

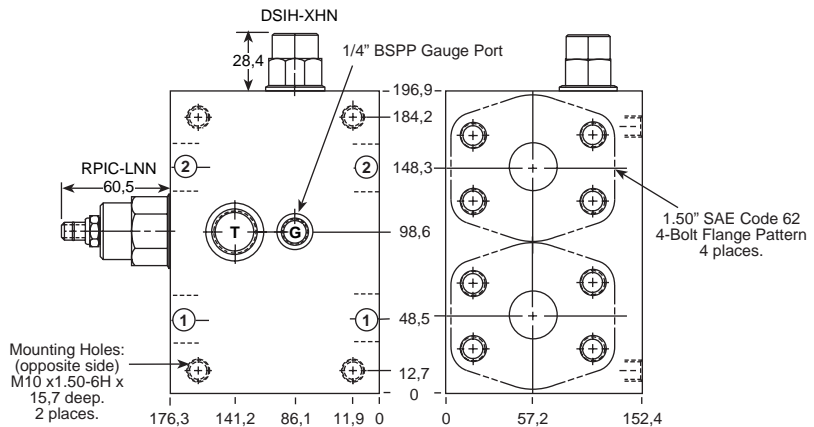

These Sun valve assemblies are for use in bleeding hot oil from the low pressure side of a hydrostatic transmission circuit. The hot oil can be cooled, filtered, or used as a source of oil for flushing other pump and motor cases. The hot oil is removed from the loop when the Sun RPIC cartridge is set below the hydrostatic charge pressure relief valve.

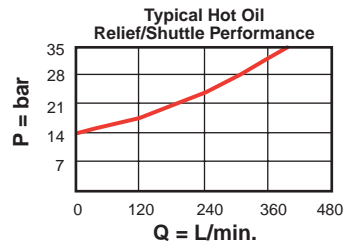

NOTES: Page 2 for cartridge model RP\*C-\*\*\* shows performance curves, technical tips, and options. See page vii for technical information about line mount bodies including SAE flange pattern specifications. Consult the Sun Factory for other port sizes available in the bodies shown above. Go to [www.sunhydraulics.com](http://www.sunhydraulics.com) for more product information.

**HOT OIL SHUTTLE AND RELIEF APPLICATIONS  
(2.00" SAE FLANGE PORT BODY)**

**PILOT OPERATED**

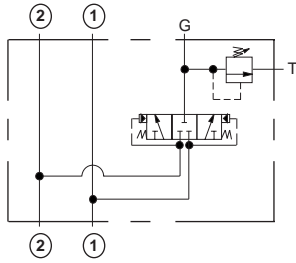

**0-380 L/min. Cavity T-16A**

Ports 1 and 2	Port T	Assembly Model Code*
2" SAE C61	1" BSPP	<b>XRJC-LNN-AS/M</b>

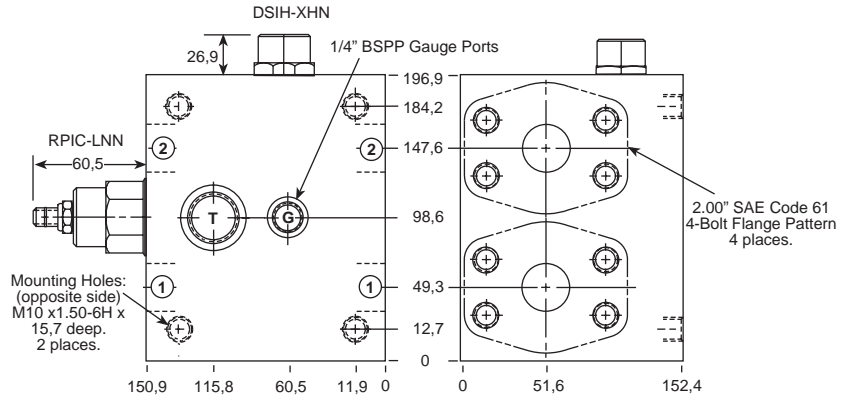

\*Add modifier **T** to order SG Iron for pressure rating over 210 bar.

These Sun valve assemblies are for use in bleeding hot oil from the low pressure side of a hydrostatic transmission circuit. The hot oil can be cooled, filtered, or used as a source of oil for flushing other pump and motor cases. The hot oil is removed from the loop when the Sun RPIC cartridge is set below the hydrostatic charge pressure relief valve.

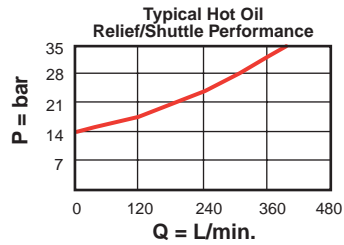

NOTES: Page 2 for cartridge model RP\*C-\*\*\* shows performance curves, technical tips, and options. See page vii for technical information about line mount bodies including SAE flange pattern specifications. Consult the Sun Factory for other port sizes available in the bodies shown above. Go to [www.sunhydraulics.com](http://www.sunhydraulics.com) for more product information.

**HYDROSTATIC TRANSMISSION APPLICATIONS  
(INLINE BODY)**

**DIRECT ACTING**

**0-95 L/min. Cavity T-10A**

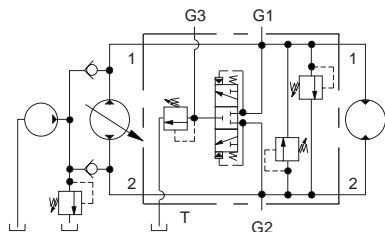

Ports 1 and 2	Port T	Ports G1, G2 & G3	Assembly Model Code*
3/4" BSPP	3/8" BSPP	1/4" BSPP	<b>XRDB-LCN-AW</b>

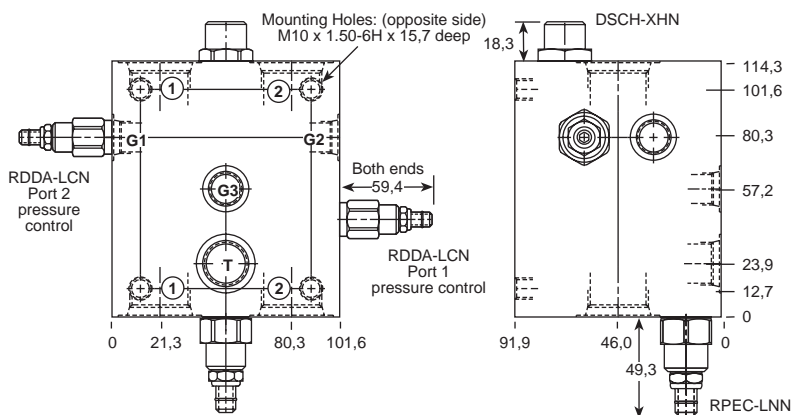

\*Add modifier /S to order SG Iron for pressure rating over 210 bar.

These Sun valve assemblies are for use with hydrostatic transmissions to provide overload relief valve protection for the main circuit in both directions. Additionally, an auxiliary shuttle valve allows bleeding of hot oil from the low pressure side. Hot oil can be cooled, filtered, or used as a source of oil for flushing other pump and motor cases. Hot oil is removed from the loop when the Sun RPEC cartridge is set below the hydrostatic charge pressure relief valve.

**NOTE: A mechanical brake is recommended to positively lock any static live load.**

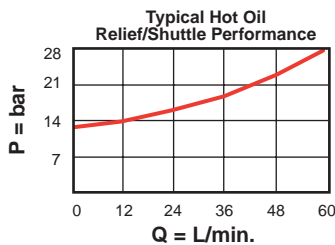

NOTES: Page 2 for cartridge models RP\*C-\*\*\* and RD\*A-\*\*\* shows performance curves, technical tips, and options. See page vii for technical information about line mount bodies including SAE flange pattern specifications. Consult the Sun Factory for other port sizes available in the bodies shown above. Go to [www.sunhydraulics.com](http://www.sunhydraulics.com) for more product information.

**HYDROSTATIC TRANSMISSION APPLICATIONS (1.00" SAE FLANGE PORT BODIES)**

**DIRECT ACTING**

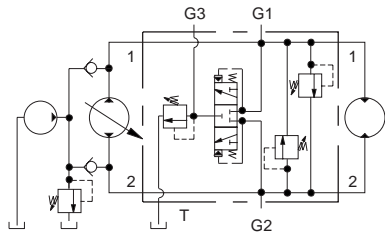

Ports 1 and 2	Port T	Ports G1, G2 & G3	Assembly Model Code*
1" SAE C61	1/2" BSPP	1/4" BSPP	<b>XRFB-LCN-AP/M</b>

**0-200 L/min. Cavity T-3A**

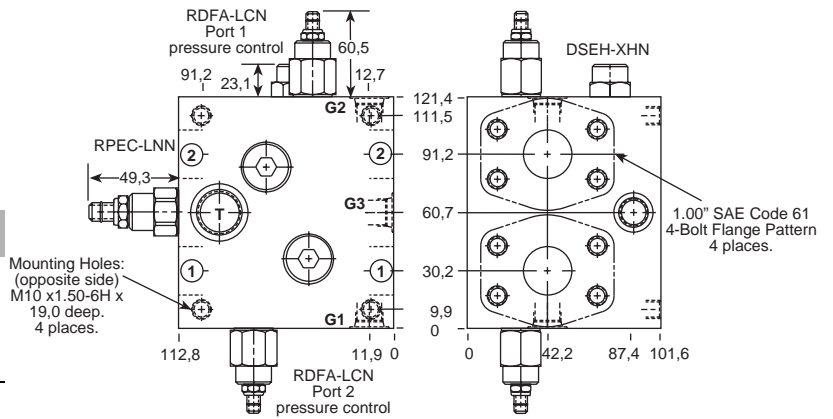

\*Add modifier **/T** to order SG Iron for pressure rating over 210 bar.

These Sun valve assemblies are for use with hydrostatic transmissions to provide overload relief valve protection for the main circuit in both directions. Additionally, an auxiliary shuttle valve allows bleeding of hot oil from the low pressure side. Hot oil can be cooled, filtered, or used as a source of oil for flushing other pump and motor cases. Hot oil is removed from the loop when the Sun RPEC cartridge is set below the hydrostatic charge pressure relief valve. **NOTE: A mechanical brake is recommended to positively lock any static live load.**

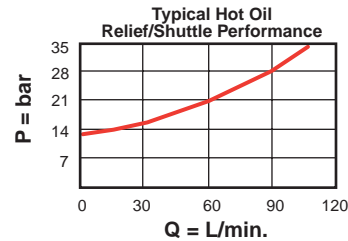

**0-200 L/min. Cavity T-3A**

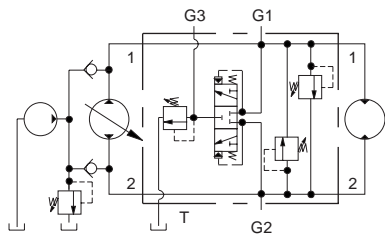

Ports 1 and 2	Port T	Ports G1, G2 & G3	Assembly Model Code*
1" SAE C62	1/2" BSPP	1/4" BSPP	<b>XRFB-LCN-A4/M</b>

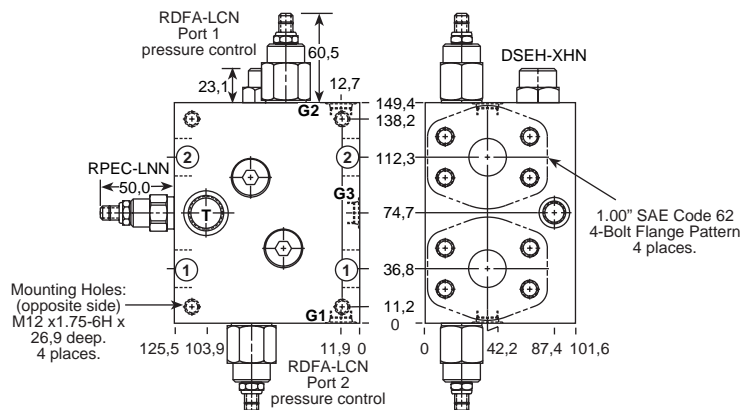

\*Add modifier **/T** to order SG Iron for pressure rating over 210 bar.

These Sun valve assemblies are for use with hydrostatic transmissions to provide overload relief valve protection for the main circuit in both directions. Additionally, an auxiliary shuttle valve allows bleeding of hot oil from the low pressure side. Hot oil can be cooled, filtered, or used as a source of oil for flushing other pump and motor cases. Hot oil is removed from the loop when the Sun RPEC cartridge is set below the hydrostatic charge pressure relief valve. **NOTE: A mechanical brake is recommended to positively lock any static live load.**

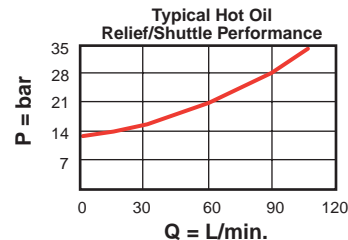

NOTES: Page 2 for cartridge models RP\*C-\*\*\* and RD\*A-\*\*\* shows performance curves, technical tips, and options. See page vii for technical information about line mount bodies including SAE flange pattern specifications. Consult the Sun Factory for other port sizes available in the bodies shown above. Go to [www.sunhydraulics.com](http://www.sunhydraulics.com) for more product information.

## Standard Assemblies: Hydrostatic Transmission Valves and Hot Oil Shuttles

# HYDROSTATIC TRANSMISSION APPLICATIONS (1.25" SAE FLANGE PORT BODIES)

### DIRECT ACTING

**0-380 L/min. Cavity T-16A**

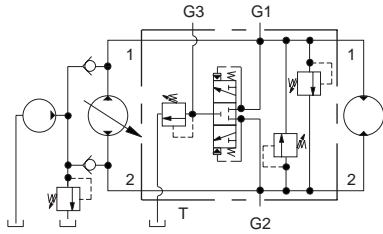

Ports 1 and 2	Port T	Ports G1, G2 & G3	Assembly Model Code*
1 1/4" SAE C61	1/4" BSPP	1/4" BSPP	<b>XRHB-LCN-AQ/M</b>

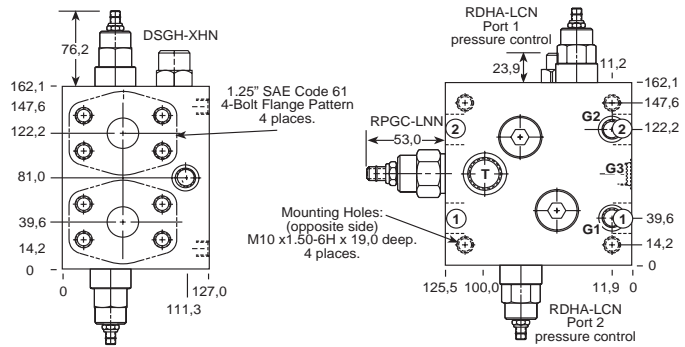

\*Add modifier **T** to order SG Iron for pressure rating over 210 bar.

These Sun valve assemblies are for use with hydrostatic transmissions to provide overload relief valve protection for the main circuit in both directions. Additionally, an auxiliary shuttle valve allows bleeding of hot oil from the low pressure side. Hot oil can be cooled, filtered, or used as a source of oil for flushing other pump and motor cases. Hot oil is removed from the loop when the Sun RPGC cartridge is set below the hydrostatic charge pressure relief valve.

**NOTE: A mechanical brake is recommended to positively lock any static live load.**

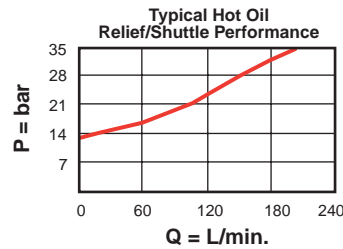

**0-380 L/min. Cavity T-16A**

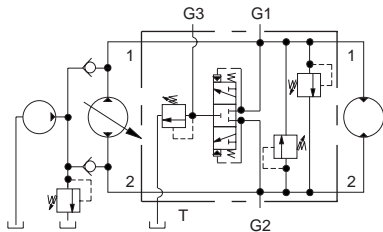

Ports 1 and 2	Port T	Ports G1, G2 & G3	Assembly Model Code*
1 1/4" SAE C62	1/4" BSPP	1/4" BSPP	<b>XRHB-LCN-A5/M</b>

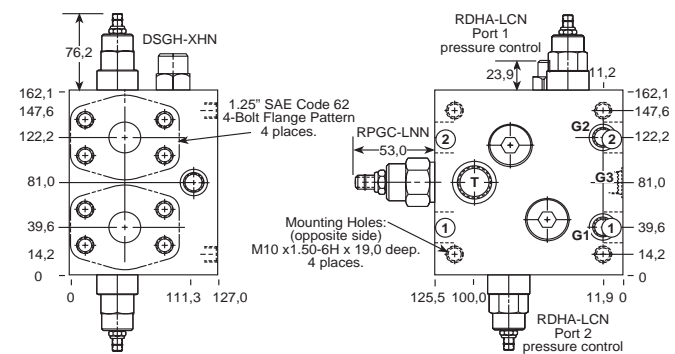

\*Add modifier **T** to order SG Iron for pressure rating over 210 bar.

These Sun valve assemblies are for use with hydrostatic transmissions to provide overload relief valve protection for the main circuit in both directions. Additionally, an auxiliary shuttle valve allows bleeding of hot oil from the low pressure side. Hot oil can be cooled, filtered, or used as a source of oil for flushing other pump and motor cases. Hot oil is removed from the loop when the Sun RPGC cartridge is set below the hydrostatic charge pressure relief valve.

**NOTE: A mechanical brake is recommended to positively lock any static live load.**

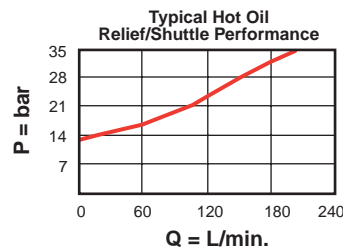

**NOTES:** Page 2 for cartridge models RP\*C-\*\*\* and RD\*A-\*\*\* shows performance curves, technical tips, and options. See page vii for technical information about line mount bodies including SAE flange pattern specifications. Consult the Sun Factory for other port sizes available in the bodies shown above. Go to [www.sunhydraulics.com](http://www.sunhydraulics.com) for more product information.



**HYDROSTATIC TRANSMISSION APPLICATIONS  
(1.50" / 2.00" SAE FLANGE PORT BODIES)**

**DIRECT ACTING**

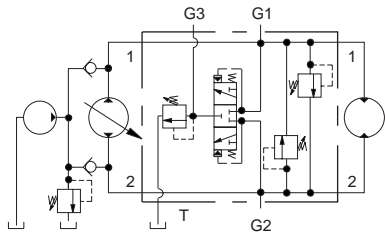

Ports 1 and 2	Port T	Ports G1, G2 & G3	Assembly Model Code*
1 1/2" SAE C61	1" BSPP	1/4" BSPP	<b>XRJB-LCN-AR/M</b>

**0-760 L/min. Cavity T-18A**

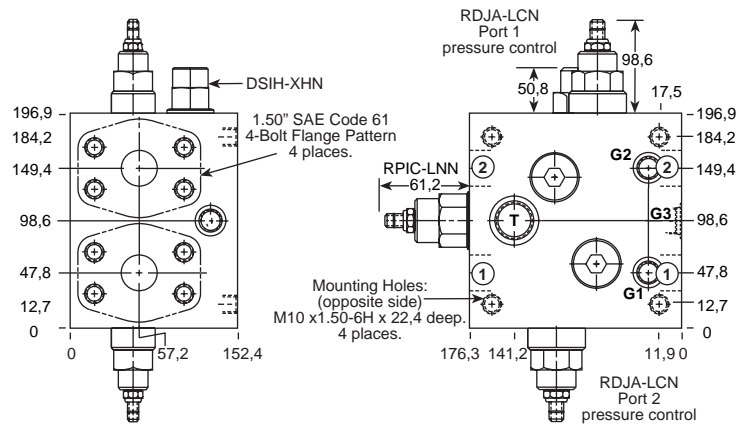

\*Add modifier **T** to order SG Iron for pressure rating over 210 bar.

These Sun valve assemblies are for use with hydrostatic transmissions to provide overload relief valve protection for the main circuit in both directions. Additionally, an auxiliary shuttle valve allows bleeding of hot oil from the low pressure side. Hot oil can be cooled, filtered, or used as a source of oil for flushing other pump and motor cases. Hot oil is removed from the loop when the Sun RPIC cartridge is set below the hydrostatic charge pressure relief valve.  
**NOTE: A mechanical brake is recommended to positively lock any static live load.**

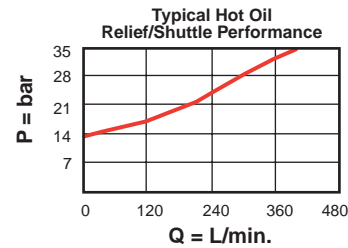

**DIRECT ACTING**

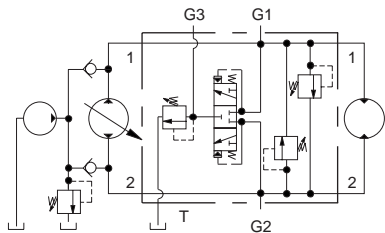

Ports 1 and 2	Port T	Ports G1, G2 & G3	Assembly Model Code*
2" SAE C61	1" BSPP	1/4" BSPP	<b>XRJB-LCN-AS/M</b>

**0-760 L/min. Cavity T-18A**

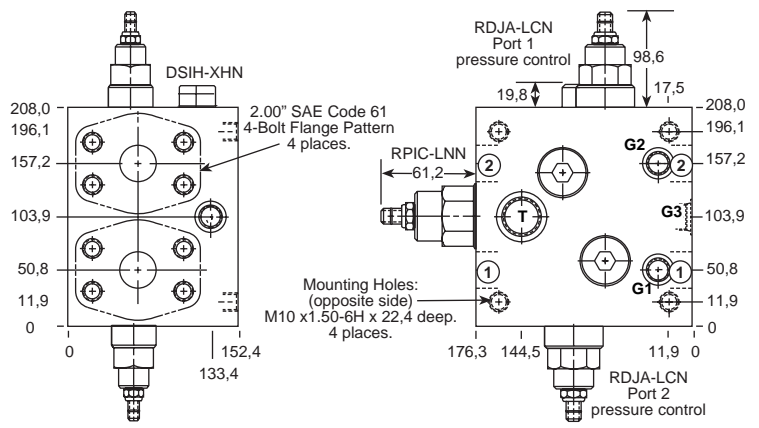

\*Add modifier **T** to order SG Iron for pressure rating over 210 bar.

These Sun valve assemblies are for use with hydrostatic transmissions to provide overload relief valve protection for the main circuit in both directions. Additionally, an auxiliary shuttle valve allows bleeding of hot oil from the low pressure side. Hot oil can be cooled, filtered, or used as a source of oil for flushing other pump and motor cases. Hot oil is removed from the loop when the Sun RPIC cartridge is set below the hydrostatic charge pressure relief valve.  
**NOTE: A mechanical brake is recommended to positively lock any static live load.**

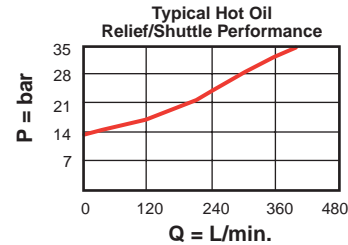

NOTES: Page 2 for cartridge models RP\*C-\*\*\* and RD\*A-\*\*\* shows performance curves, technical tips, and options. See page vii for technical information about line mount bodies including SAE flange pattern specifications. Consult the Sun Factory for other port sizes available in the bodies shown above. Go to [www.sunhydraulics.com](http://www.sunhydraulics.com) for more product information.