



ISO 03 SANDWICH BODIES



- Aluminum rated to 3000 psi and Ductile Iron rated to 5000 psi.
- See page viii for ordering cartridge/body and seals. Pressure ratings, material specifications on page xiv.

03 CHECK

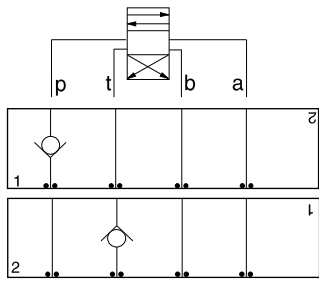

FUNCTION

On P

On T

Check Valves

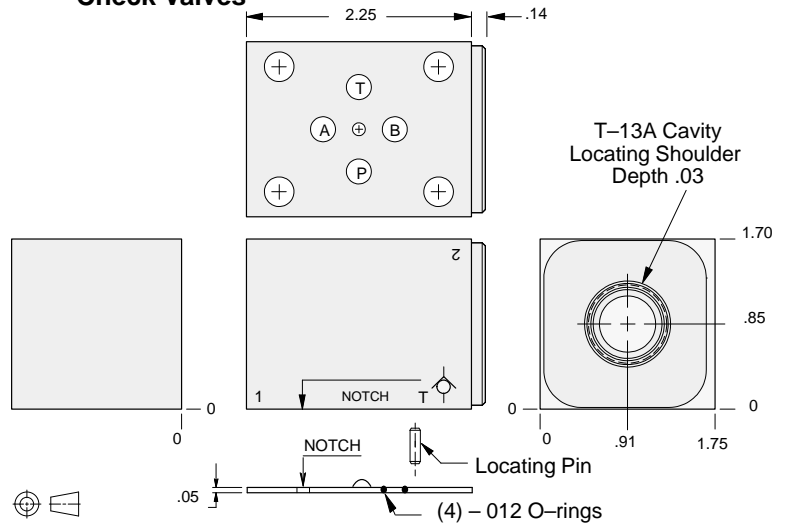

ALUMINUM		DUCTILE IRON	
Model Code	List Price	Model Code	List Price
GDP		GDP/S	

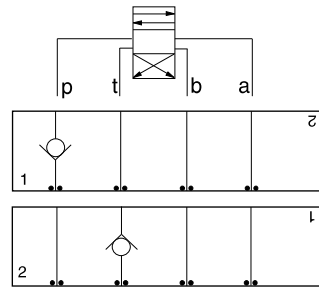
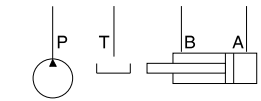

FUNCTION

On P
(High Capacity)

On T
(High Capacity)

Check Valves

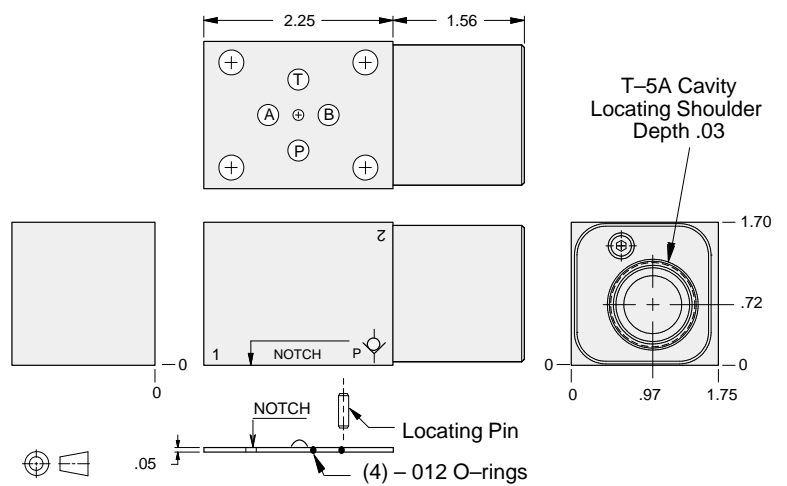

ALUMINUM		DUCTILE IRON	
Model Code	List Price	Model Code	List Price
GDO		GDO/S	

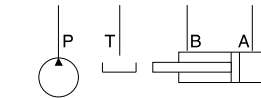

TYPICAL CARTRIDGES USED WITH BODIES SHOWN ABOVE

	Check Valve, Free Flow Port 1 to Port 2 (Nose-to-Side)		
	CXDA Page 5.08 (use with GDP)		
	Check Valve, Free Flow Port 1 to Port 2 (Nose-to-Side)		
	CXFA Page 5.08 (use with GDO)		
OTHER VALVES:			



ISO 03 SANDWICH BODIES



- Aluminum rated to 3000 psi and Ductile Iron rated to 5000 psi.
- See page viii for ordering cartridge/body and seals. Pressure ratings, material specifications on page xiv.

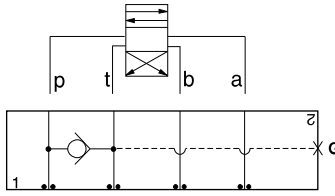

FUNCTION

T to P

Check Valves

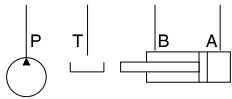
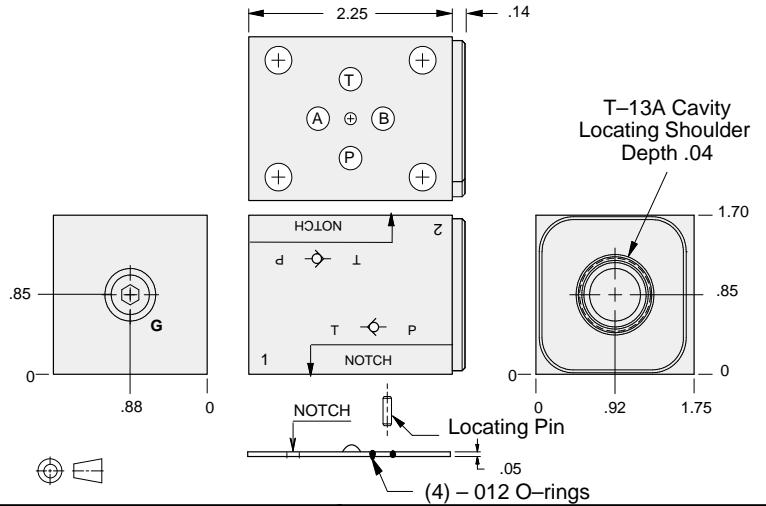

Gage Port (Plugged)	ALUMINUM		DUCTILE IRON	
	Model Code	List Price	Model Code	List Price
.25 NPTF	GDQ		GDQ/S	
.25 BSPP	GDQ/M		GDQ/T	

03 CHECK

TYPICAL CARTRIDGES USED WITH BODIES SHOWN ABOVE			
	Check Valve, Free Flow Port 1 to Port 2 (Nose-to-Side)		
	CXDA Page 5.08		
OTHER VALVES:			



ISO 03 SANDWICH BODIES



- Aluminum rated to 3000 psi and Ductile Iron rated to 5000 psi.
- See page viii for ordering cartridge/body and seals. Pressure ratings, material specifications on page xiv.

03 CHECK

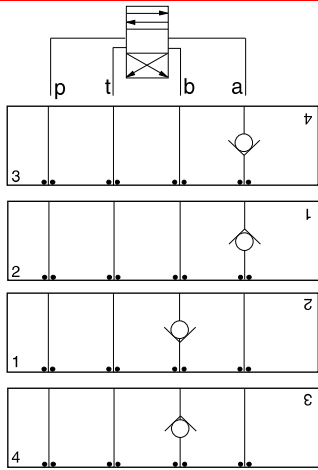

FUNCTION

On A
Free Flow Into Valve

On A
Free Flow Out of Valve

On B
Free Flow Into Valve

On B
Free Flow Out of Valve

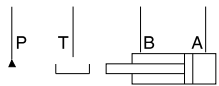

Check Valves

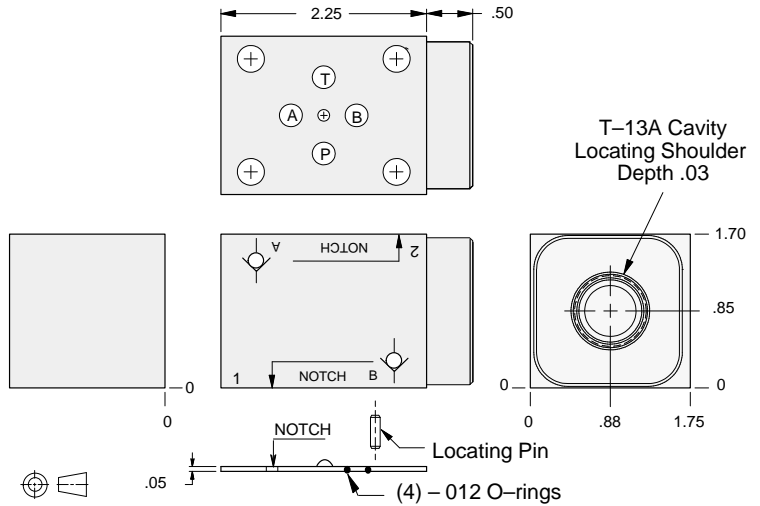

ALUMINUM		DUCTILE IRON	
Model Code	List Price	Model Code	List Price
GDA		GDA/S	

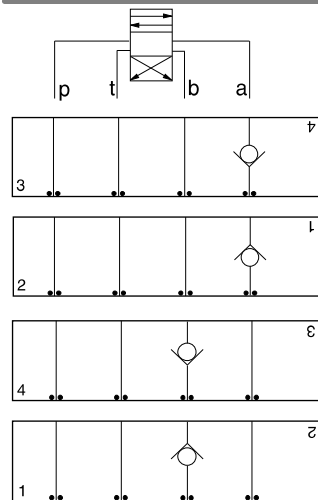

FUNCTION

On A
Free Flow Into Valve
(High Capacity)

On A
Free Flow Out of Valve
(High Capacity)

On B
Free Flow Into Valve
(High Capacity)

On B
Free Flow Out of Valve
(High Capacity)

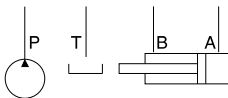

Check Valves

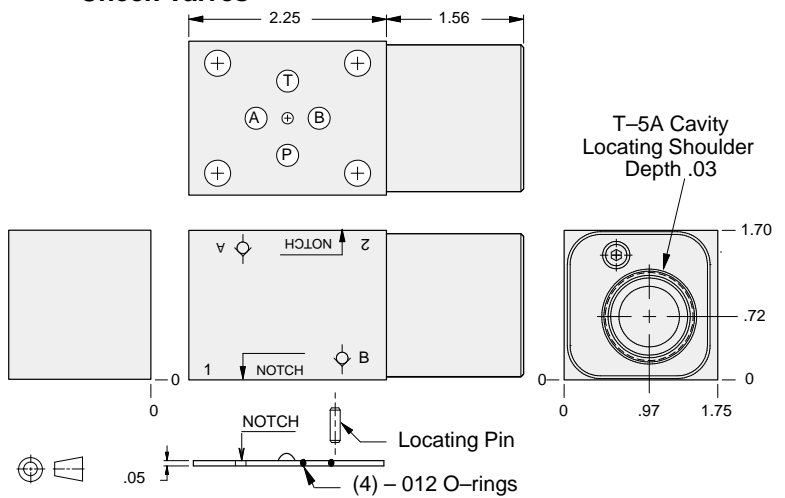

ALUMINUM		DUCTILE IRON	
Model Code	List Price	Model Code	List Price
GDD		GDD/S	

TYPICAL CARTRIDGES USED WITH BODIES SHOWN ABOVE

	Check Valve, Free Flow Port 1 to Port 2 (Nose-to-Side)		
	CXDA Page 5.08 (use with GDA)		
	Check Valve, Free Flow Port 1 to Port 2 (Nose-to-Side)		
	CXFA Page 5.08 (use with GDD)		
OTHER VALVES:			



ISO 03 SANDWICH BODIES



- Aluminum rated to 3000 psi and Ductile Iron rated to 5000 psi.
- See page viii for ordering cartridge/body and seals. Pressure ratings, material specifications on page xiv.

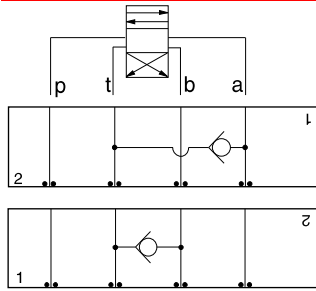

FUNCTION

T to A

T to B

Check Valves

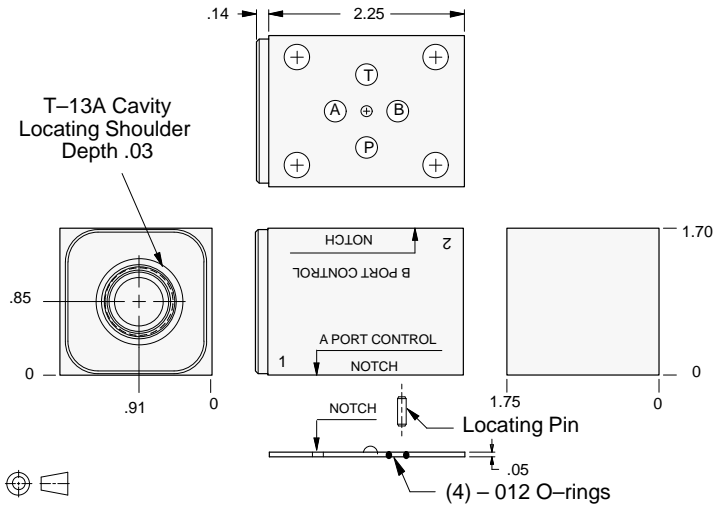

ALUMINUM		DUCTILE IRON	
Model Code	List Price	Model Code	List Price
GDW		GDW/S	

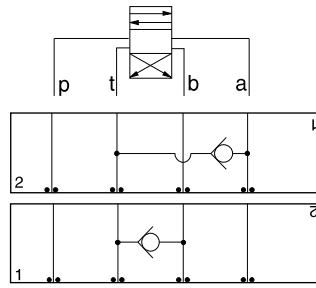

FUNCTION

T to A
(High Capacity)

T to B
(High Capacity)

Check Valves

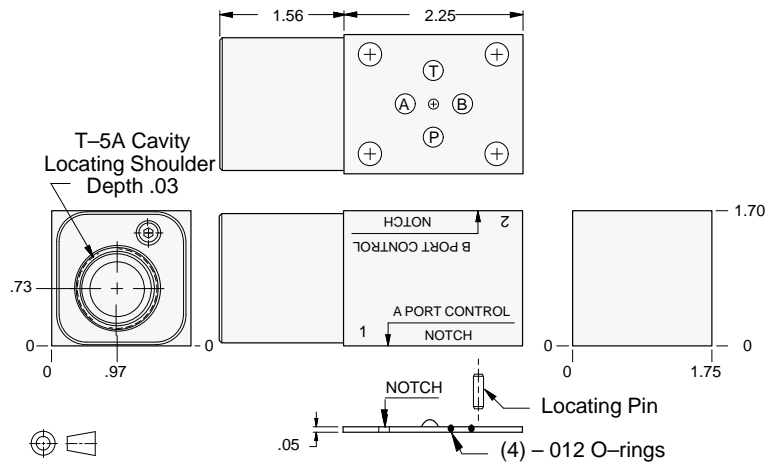

ALUMINUM		DUCTILE IRON	
Model Code	List Price	Model Code	List Price
GDE		GDE/S	

TYPICAL CARTRIDGES USED WITH BODIES SHOWN ABOVE

	Check Valve, Free Flow Port 1 to Port 2 (Nose-to-Side)		
	CXDA Page 5.08 (use with GDW)		
	Check Valve, Free Flow Port 1 to Port 2 (Nose-to-Side)		
	CXFA Page 5.08 (use with GDE)		
OTHER VALVES:			



ISO 03 SANDWICH BODIES



- Aluminum rated to 3000 psi and Ductile Iron rated to 5000 psi.
- See page viii for ordering cartridge/body and seals. Pressure ratings, material specifications on page xiv.

03 CHECK

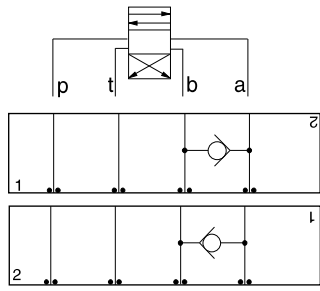

FUNCTION

A to B

B to A

Check Valves

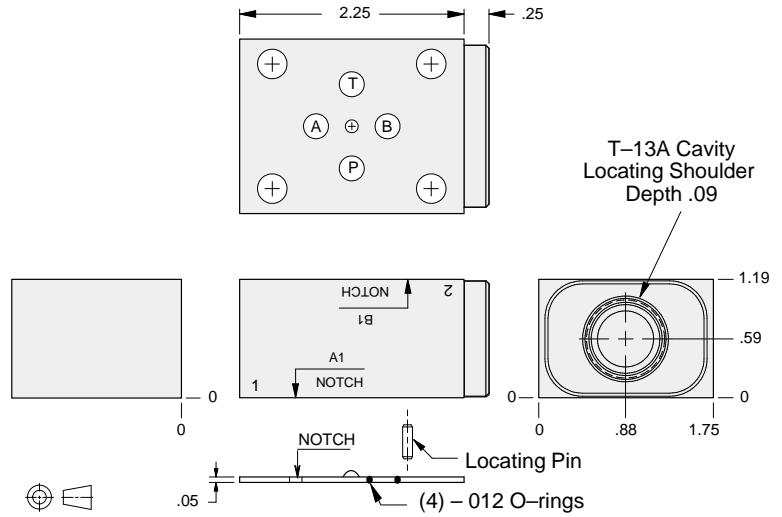

ALUMINUM		DUCTILE IRON	
Model Code	List Price	Model Code	List Price
GBS		GBS/S	

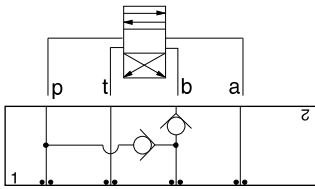

FUNCTION

B to P
(For Regenerative Circuits)

Check Valves

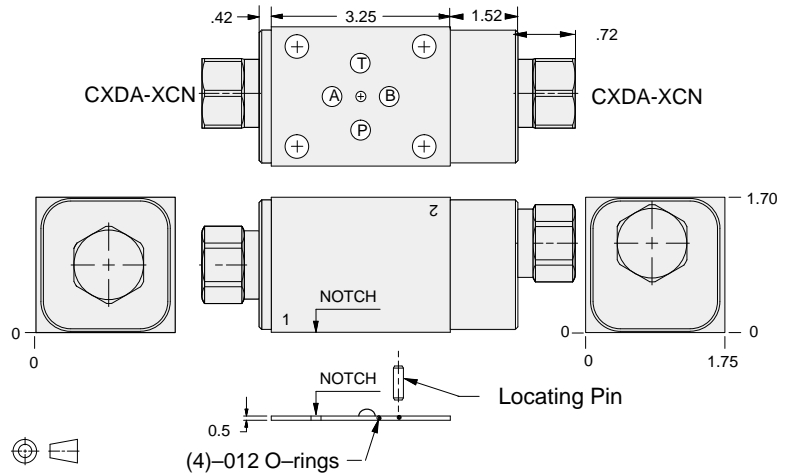

ALUMINUM		DUCTILE IRON	
Model Code	List Price	Model Code	List Price
YDCK-XCN-AA		YDCK-XCN-AA/S	

TYPICAL CARTRIDGES USED WITH BODIES SHOWN ABOVE			
	Check Valve, Free Flow Port 1 to Port 2 (Nose-to-Side)		
	CXDA Page 5.08		
OTHER VALVES:			



ISO 03 SANDWICH BODIES



- Aluminum rated to 3000 psi and Ductile Iron rated to 5000 psi.
- See page viii for ordering cartridge/body and seals. Pressure ratings, material specifications on page xiv.

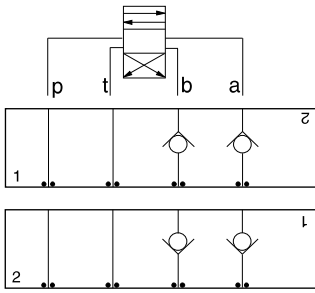

FUNCTION

On A and B
Free Flow **Out** of Valve

On A and B
Free Flow **Into** Valve

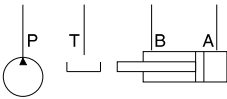

Check Valves

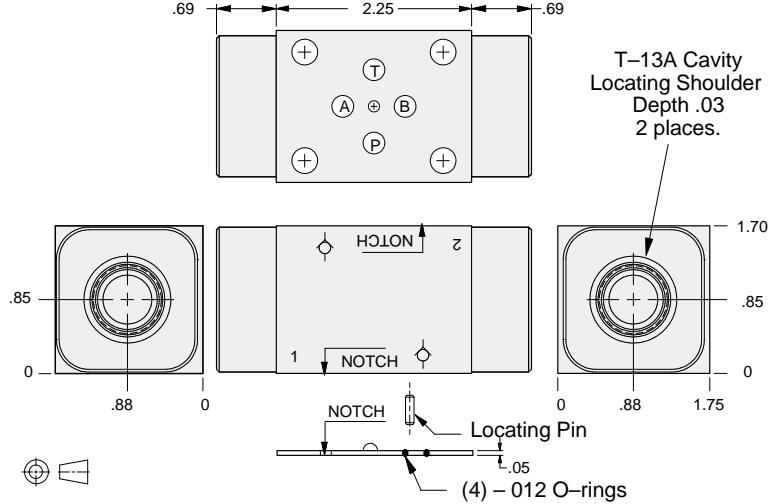

ALUMINUM		DUCTILE IRON	
Model Code	List Price	Model Code	List Price
GDY		GDY/S	

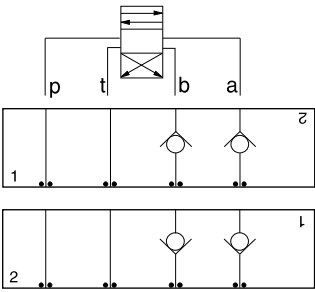

FUNCTION

On A and B
Free Flow **Out**
of Valve (High Capacity)

On A and B
Free Flow **Into** Valve
(High Capacity)

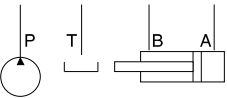

Check Valves

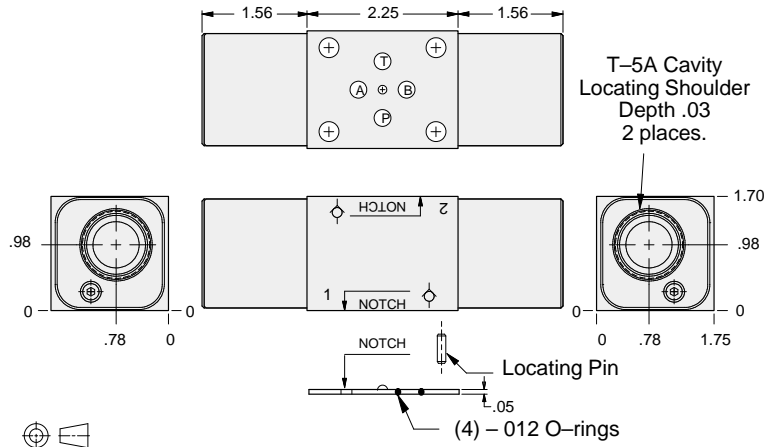

ALUMINUM		DUCTILE IRON	
Model Code	List Price	Model Code	List Price
GDZ		GDZ/S	

TYPICAL CARTRIDGES USED WITH BODIES SHOWN ABOVE

	Check Valve, Free Flow Port 1 to Port 2 (Nose-to-Side)		
	CXDA Page 5.08 (use with GDY)		
	Check Valve, Free Flow Port 1 to Port 2 (Nose-to-Side)		
	CXFA Page 5.08 (use with GDZ)		
OTHER VALVES:			



ISO 03 SANDWICH BODIES



- Aluminum rated to 3000 psi and Ductile Iron rated to 5000 psi.
- See page viii for ordering cartridge/body and seals. Pressure ratings, material specifications on page xiv.

03 CHECK

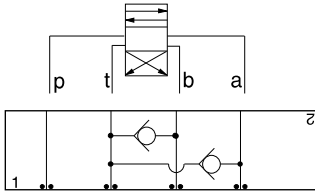

FUNCTION

T to A and B

Check Valves

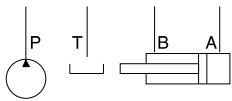
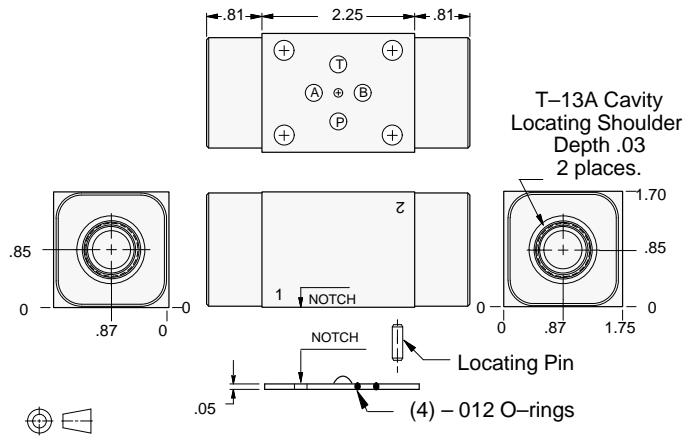

ALUMINUM		DUCTILE IRON	
Model Code	List Price	Model Code	List Price
GDX		GDX/S	

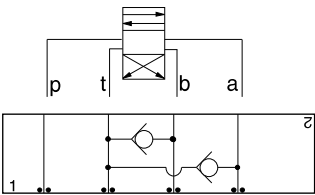

FUNCTION

T to A and B
(High Capacity)

Check Valves

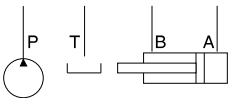
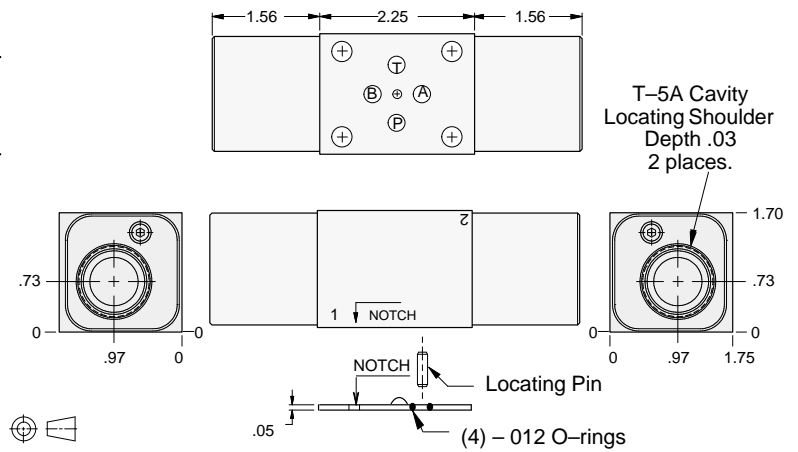

ALUMINUM		DUCTILE IRON	
Model Code	List Price	Model Code	List Price
GDF		GDF/S	

TYPICAL CARTRIDGES USED WITH BODIES SHOWN ABOVE

	Check Valve, Free Flow Port 1 to Port 2 (Nose-to-Side)		
	CXDA Page 5.08 (use with GDX)		
	Check Valve, Free Flow Port 1 to Port 2 (Nose-to-Side)		
	CXFA Page 5.08 (use with GDF)		
OTHER VALVES:			