

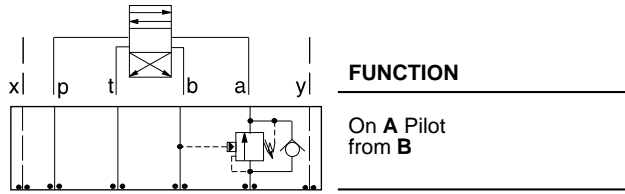

ISO 08 SANDWICH BODIES



- Aluminum rated to 3000 psi and Ductile Iron rated to 5000 psi.
- See page viii for ordering cartridge/body and seals. Pressure ratings, material specifications on page xiv.



Counterbalance Valves

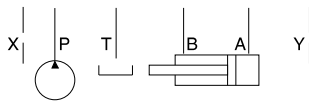
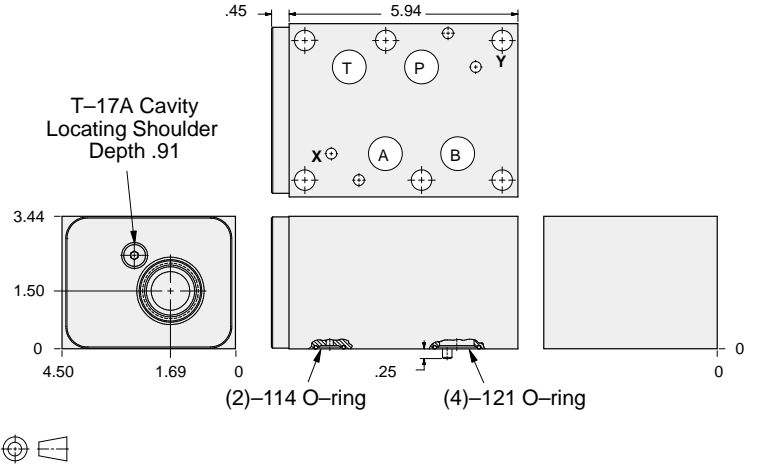

ALUMINUM		DUCTILE IRON	
Model Code	List Price	Model Code	List Price
HBL		HBL/S	

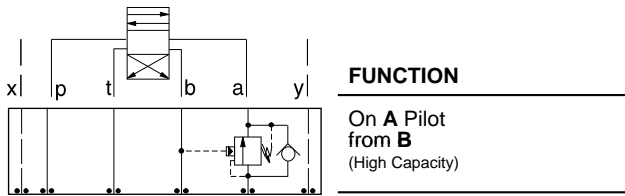

Counterbalance Valves

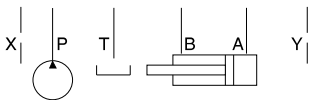
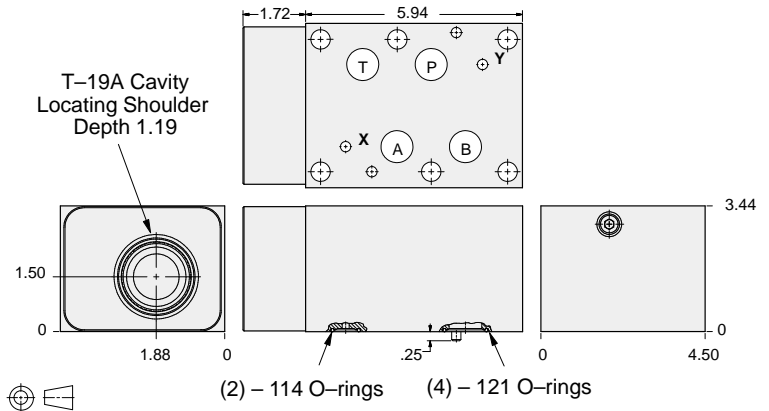

ALUMINUM		DUCTILE IRON	
Model Code	List Price	Model Code	List Price
HBA		HBA/S	

TYPICAL CARTRIDGES USED WITH BODIES SHOWN ABOVE			
	Counterbalance Valve, 3:1 Pilot Ratio		
	CB*A Page 4.11		
	Counterbalance Valve, 4.5:1 Pilot Ratio		
	CB*G Page 4.13		
	Counterbalance Valve, 10:1 Pilot Ratio		
	CB*H Page 4.15		
OTHER VALVES:			

08 COUNTERBALANCE



ISO 08 SANDWICH BODIES



- Aluminum rated to 3000 psi and Ductile Iron rated to 5000 psi.
- See page viii for ordering cartridge/body and seals. Pressure ratings, material specifications on page xiv.

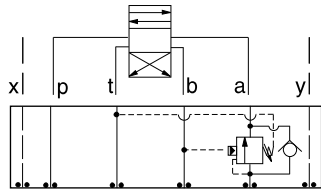

FUNCTION

On A Pilot from B
Vent to T

Counterbalance Valves

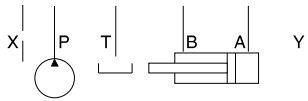
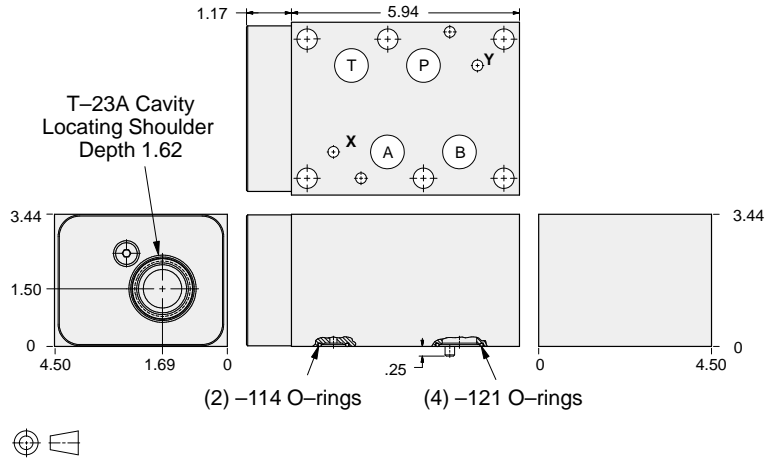

ALUMINUM		DUCTILE IRON	
Model Code	List Price	Model Code	List Price
PBA		PBA/S	

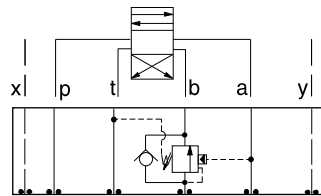

FUNCTION

On B Pilot from A
Vent to T

Counterbalance Valves

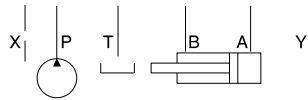
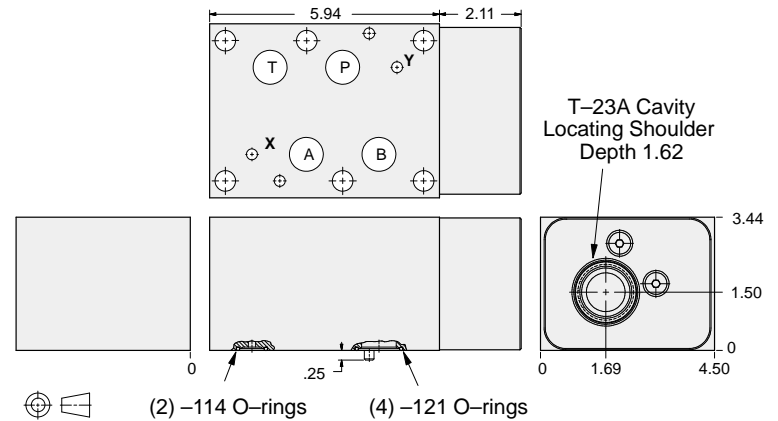

ALUMINUM		DUCTILE IRON	
Model Code	List Price	Model Code	List Price
PBB		PBB/S	

TYPICAL CARTRIDGES USED WITH BODIES SHOWN ABOVE

	Vented Counterbalance Valve, 3:1 Pilot Ratio		
	CWGA Page 4.19		
	Vented Counterbalance Valve, 5:1 Pilot Ratio		
	CWGG Page 4.21		
OTHER VALVES:			



ISO 08 SANDWICH BODIES



- Aluminum rated to 3000 psi and Ductile Iron rated to 5000 psi.
- See page viii for ordering cartridge/body and seals. Pressure ratings, material specifications on page xiv.

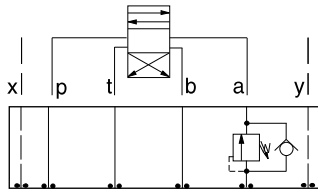

FUNCTION

On A
No pilot assist

Counterbalance Valves

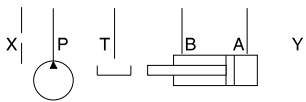
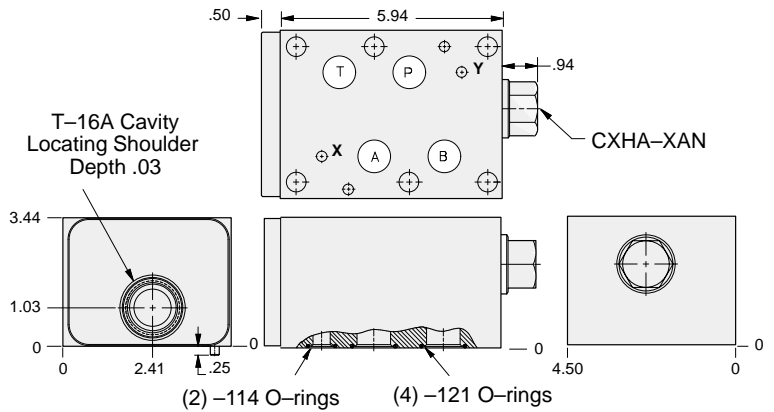

ALUMINUM		DUCTILE IRON	
Model Code	List Price	Model Code	List Price
CD4		CD4/S	

TYPICAL CARTRIDGES USED WITH BODIES SHOWN ABOVE

	Direct Acting Relief Valve		
	RDHA Page 1.09		
OTHER VALVES:			



ISO 08 SANDWICH BODIES



- Aluminum rated to 3000 psi and Ductile Iron rated to 5000 psi.
- See page viii for ordering cartridge/body and seals. Pressure ratings, material specifications on page xiv.

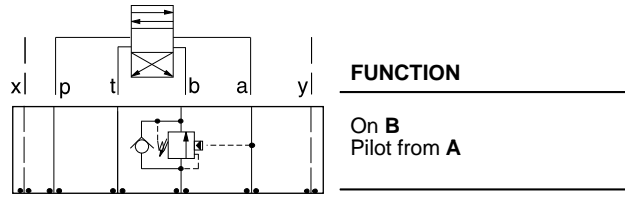

Counterbalance Valves

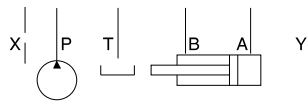
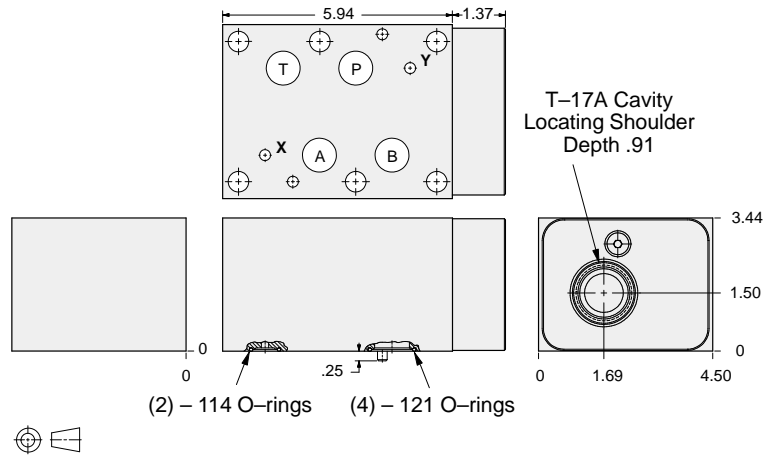

ALUMINUM		DUCTILE IRON	
Model Code	List Price	Model Code	List Price
HBM		HBM/S	

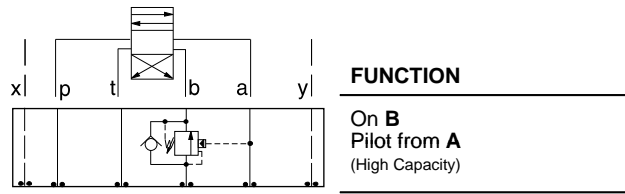

Counterbalance Valves

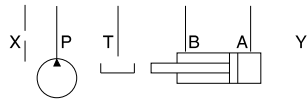
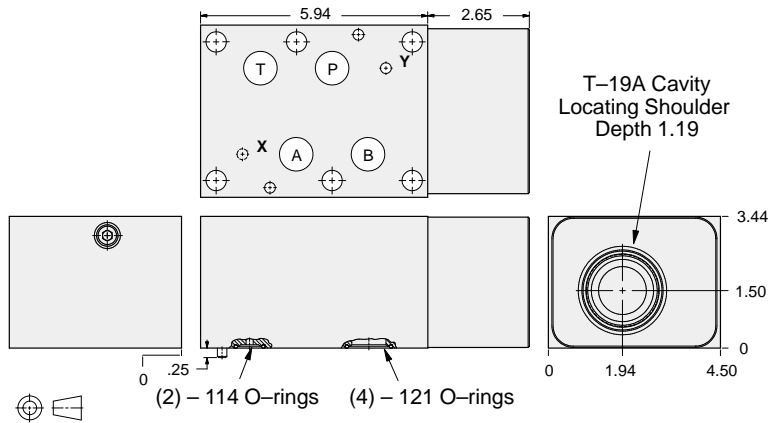

ALUMINUM		DUCTILE IRON	
Model Code	List Price	Model Code	List Price
HBB		HBB/S	

08 COUNTERBALANCE

TYPICAL CARTRIDGES USED WITH BODIES SHOWN ABOVE			
	Counterbalance Valve, 3:1 Pilot Ratio CB*A Page 4.11		
	Counterbalance Valve, 4.5:1 Pilot Ratio CB*G Page 4.13		
	Counterbalance Valve, 10:1 Pilot Ratio CB*H Page 4.15		
OTHER VALVES:			



ISO 08 SANDWICH BODIES



- Aluminum rated to 3000 psi and Ductile Iron rated to 5000 psi.
- See page viii for ordering cartridge/body and seals. Pressure ratings, material specifications on page xiv.

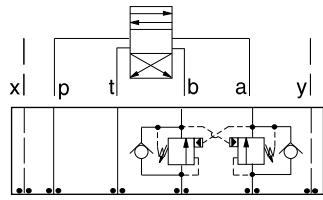

FUNCTION

On A and B
Cross-Piloted

Counterbalance Valves

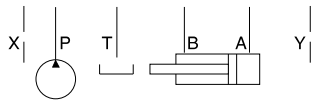
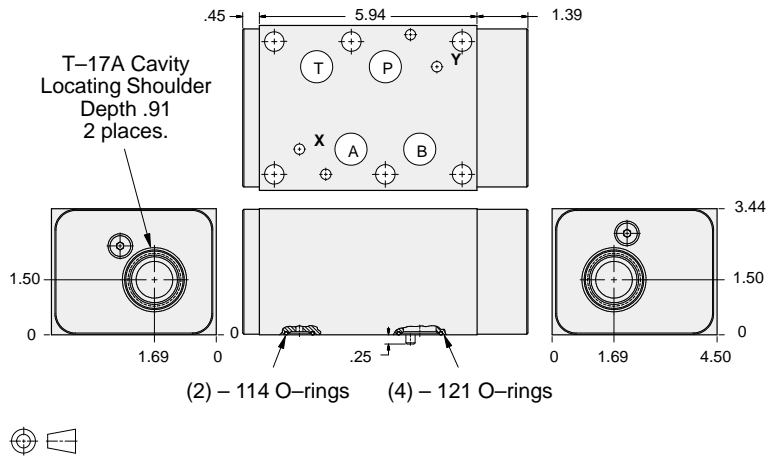

ALUMINUM		DUCTILE IRON	
Model Code	List Price	Model Code	List Price
HBN		HBN/S	

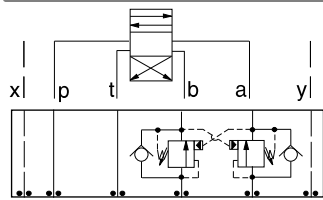

FUNCTION

On A and B
Cross-Piloted
(High Capacity)

Counterbalance Valves

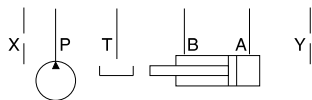
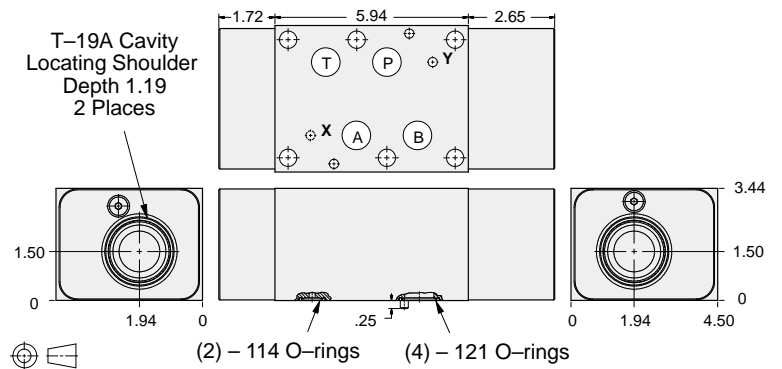

ALUMINUM		DUCTILE IRON	
Model Code	List Price	Model Code	List Price
HBY		HBY/S	

TYPICAL CARTRIDGES USED WITH BODIES SHOWN ABOVE

	Counterbalance Valve, 3:1 Pilot Ratio		
	CB*A Page 4.11		
	Counterbalance Valve, 4.5:1 Pilot Ratio		
	CB*G Page 4.13		
	Counterbalance Valve, 10:1 Pilot Ratio		
	CB*H Page 4.15		
OTHER VALVES:			



ISO 08 SANDWICH BODIES



- Aluminum rated to 3000 psi and Ductile Iron rated to 5000 psi.
- See page viii for ordering cartridge/body and seals. Pressure ratings, material specifications on page xiv.

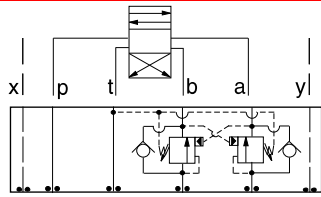

FUNCTION

On **A** and **B**
Cross-Piloted
Vents to T

Counterbalance Valves

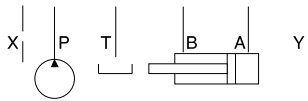
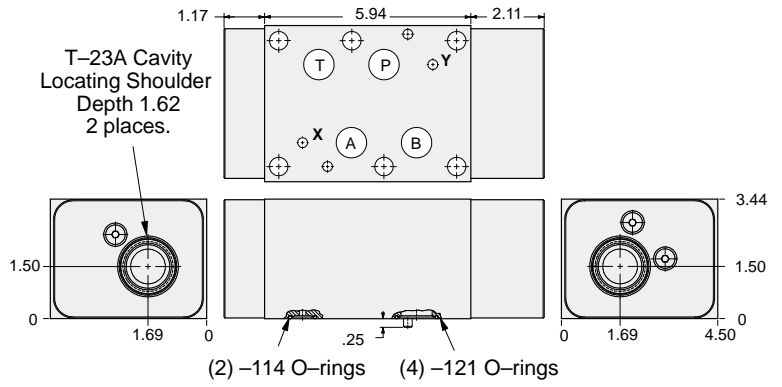

ALUMINUM		DUCTILE IRON	
Model Code	List Price	Model Code	List Price
PBY		PBY/S	

08 COUNTERBALANCE

TYPICAL CARTRIDGES USED WITH BODIES SHOWN ABOVE			
	Vented Counterbalance Valve, 3:1 Pilot Ratio		
	CWGA Page 4.19		
	Vented Counterbalance Valve, 5:1 Pilot Ratio		
	CWGG Page 4.21		
OTHER VALVES:			