

**TECHNICAL PRODUCT INFORMATION**  
**DIRECT MOTOR MOUNTED ASSEMBLIES**  
**Char-Lynn S Series**

*Applications*

The gerotor type gear motor is used on a large number of mobile and industrial applications. It is often necessary to incorporate valves in the circuit with the motor to control the flow and pressure. It may also be necessary to incorporate load control valves in the circuit.

It is possible to mount line mounted valves into the pipework feeding the motor, but Sun offers a large range of valves that can be bolted directly onto the motor interface. This eliminates pipework and provides the control directly at the motor.

The use of Sun cartridge valves in these assemblies means that in the event of a problem, it is a simple task to replace the cartridge rather than have to replace the complete valve.

On the smaller size motors the same gasket mounted face is used by at least four different manufacturers of this type of motor. The list below provides a quick cross-reference.

***Manufacturer (general motor type with gasket mounted interface)***

Eaton (S Type)  
White (RS 06 and RS 46)  
Parker/Ross/Nichols/Prince (TA, TB, TD, NE, 110A, 130S, 400S)

**On the specification in this catalogue for the smaller size of motor, we are using the Eaton reference number type as they are probably the largest manufacturer.**

For the larger size of motors we are only showing the Eaton reference of 2000 series and 4000 series.

*Design Concepts and Features*

The valve assemblies shown for all sizes of motor are counterbalance valves and cross line relief valves. The counterbalance valves provide load holding and load control while the cross line relief valves provide over pressure protection. The Sun counterbalance valves provide excellent control with low hysteresis and minimum leakage. The relief valves are fast acting with minimum overshoot for excellent protection.

On the smaller sizes of motor, Sun also offers flow control, which can accurately control the motor speed. The type of valve offered is a pressure compensated flow control valve but for more basic flow control a simple restrictor valve can also be used. Sun also has a further expanded range of bolt on valve assemblies. Consult the Sun factory or your local distributor for further information.

# Standard Assemblies: Direct Motor Mounted Assemblies: Char-Lynn S Series Motors

## SINGLE / DUAL CROSS-PORT RELIEF AND SINGLE COUNTERBALANCE APPLICATIONS

### T-10A / T-11A Cavities

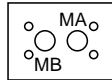

Go to [www.sunhydraulics.com](http://www.sunhydraulics.com) for more product information.

#### DIRECT ACTING

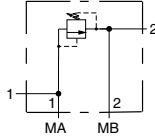

Rotate manifold for relief direction required. Relieves from 1 to 2.

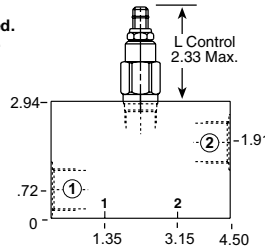

#### PILOT RATIO 3:1

#### Function

Single Cross-Port Relief A to B

<b>Ports</b> 1, 2	<b>Assembly Model Code*</b>
SAE 10	<b>RDDA-L*N-ZFK</b>

\*Add modifier /S to order Ductile Iron for pressure rating over 3000 psi.

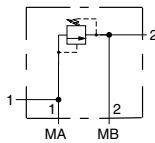

Rotate manifold for relief direction required. Relieves from 1 to 2.

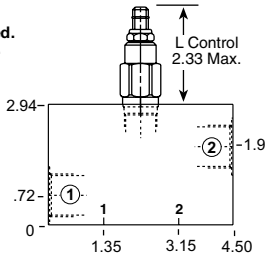

#### Function

Single Cross-Port Relief B to A

<b>Ports</b> 1, 2	<b>Assembly Model Code*</b>
SAE 10	<b>RDDA-L*N-ZFK</b>

\*Add modifier /S to order Ductile Iron for pressure rating over 3000 psi.

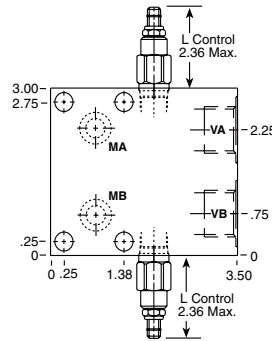
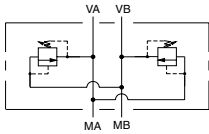

#### Function

Dual Cross-Port Relief

<b>Ports</b> A, B	<b>Assembly Model Code*</b>
SAE 8	<b>RDDA-L*N-YXB</b>

\*Add modifier /S to order Ductile Iron for pressure rating over 3000 psi.

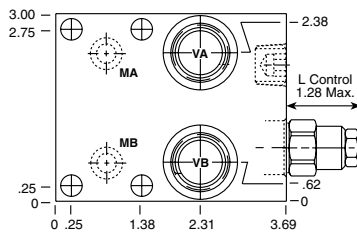
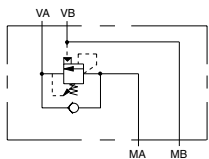

#### Function

Single Counterbalance on A

<b>Ports</b> VA, VB	<b>Assembly Model Code*</b>
SAE 10	<b>CBCA-LAN-ZPD</b>

\*Add modifier /S to order Ductile Iron for pressure rating over 3000 psi.

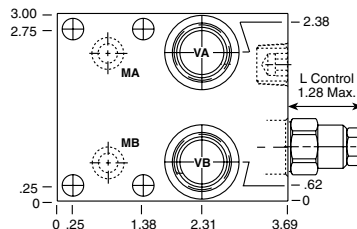
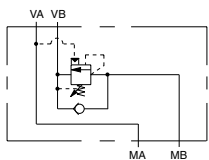

#### Function

Single Counterbalance on B

<b>Ports</b> VA, VB	<b>Assembly Model Code*</b>
SAE 10	<b>CBCA-LAN-ZPB</b>

\*Add modifier /S to order Ductile Iron for pressure rating over 3000 psi.

NOTES: Page 2 for cartridge model RD\*A-\*\*\* and page 50 for CB\*\*-\* show performance curves, technical tips, and options. See page 229 for technical information about bolt-on packages.

**SINGLE / DUAL COUNTERBALANCE AND DUAL FLOW CONTROL APPLICATIONS**

**T-11A / T-13A Cavities**

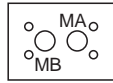

Go to [www.sunhydraulics.com](http://www.sunhydraulics.com) for more product information.

**FULLY ADJUSTABLE PRESSURE COMPENSATED WITH FREE FLOW CHECK**

**PILOT RATIO 3:1**

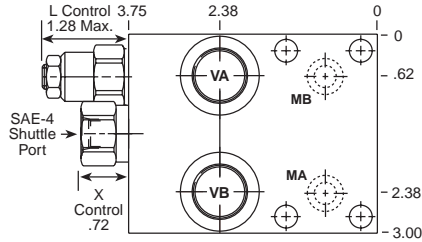
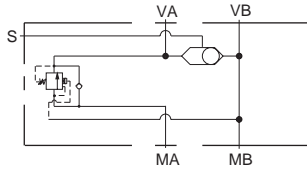

**Function**  
Single Counterbalance on A with Shuttle

<b>Ports</b> VA, VB	<b>Assembly Model Code*</b>
SAE 10	<b>CBCA-LAN-ZDV</b>

\*Add modifier /S to order Ductile Iron for pressure rating over 3000 psi.

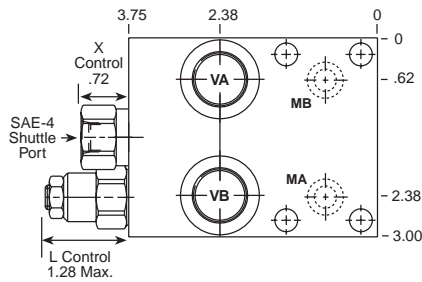
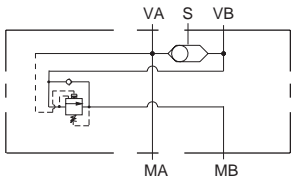

**Function**  
Single Counterbalance on B with Shuttle

<b>Ports</b> VA, VB	<b>Assembly Model Code*</b>
SAE 10	<b>CBCA-LAN-ZDY</b>

\*Add modifier /S to order Ductile Iron for pressure rating over 3000 psi.

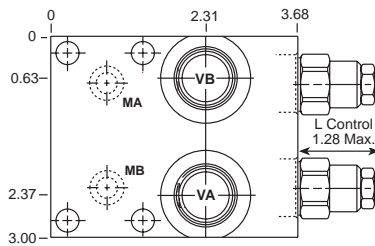
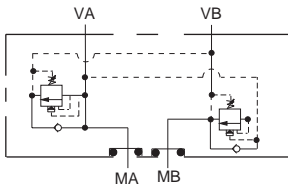

**Function**  
Dual Counterbalance

<b>Ports</b> VA, VB	<b>Assembly Model Code*</b>
SAE 10	<b>CBCA-LAN-YTA</b>

\*Add modifier /S to order Ductile Iron for pressure rating over 3000 psi.

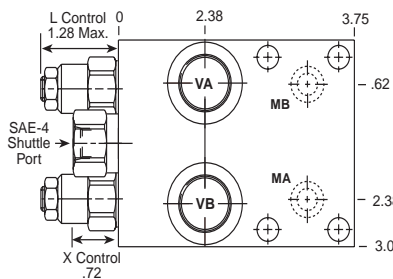
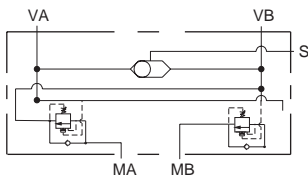

**Function**  
Dual Counterbalance with Shuttle

<b>Ports</b> VA, VB	<b>Assembly Model Code*</b>
SAE 10	<b>CBCA-LAN-XTS</b>

\*Add modifier /S to order Ductile Iron for pressure rating over 3000 psi.

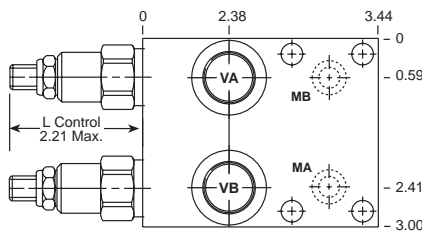
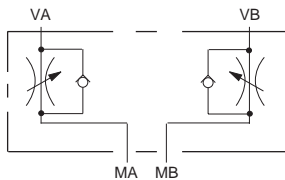

**Function**  
Dual Flow Control Meter-out on A and B

<b>Ports</b> VA, VB	<b>Assembly Model Code*</b>
SAE 10	<b>FDBA-LAN-XWT</b>

\*Add modifier /S to order Ductile Iron for pressure rating over 3000 psi.

NOTES: Page 126 for cartridge model FD\*\*-\*\*\* and page 50 for CB\*\*-\*\*\* show performance curves, technical tips, and options. See page 229 for technical information about bolt-on packages.

SINGLE FLOW CONTROL APPLICATIONS

T-13A Cavity



Go to [www.sunhydraulics.com](http://www.sunhydraulics.com) for more product information.

FULLY ADJUSTABLE

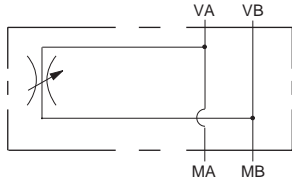

Function

Single Flow Control Bleed-Off

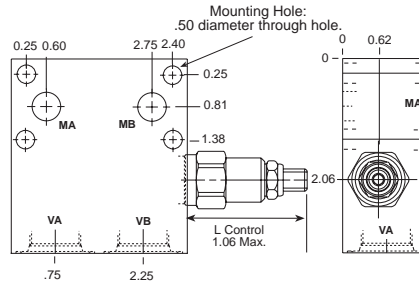

Ports VA, VB	Assembly Model Code*
SAE 10	NFCC-LCN-ZFZ

\*Add modifier /S to order Ductile Iron for pressure rating over 3000 psi.

NOTES: Page 110 for cartridge model NF\*\*-\*\*\* show performance curves, technical tips, and options. See page 229 for technical information about bolt-on packages.

DUAL CROSS-PORT RELIEF AND SINGLE COUNTERBALANCE APPLICATIONS

T-10A / T-2A Cavities

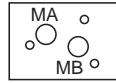

Go to [www.sunhydraulics.com](http://www.sunhydraulics.com) for more product information.

DIRECT ACTING

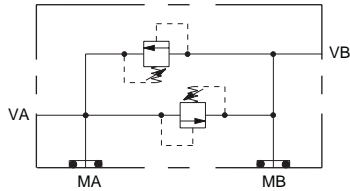

Ports VA, VB  
SAE 10  
Assembly Model Code\*  
**RDDA-L\*N-YWA**

\*Add modifier **/S** to order Ductile Iron for pressure rating over 3000 psi.

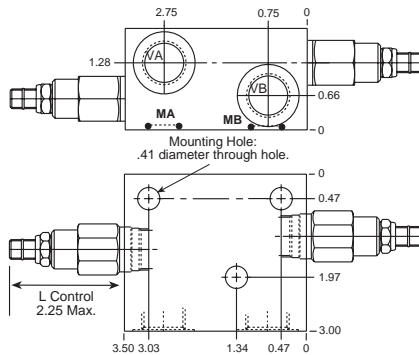

PILOT RATIO 3:1

Function  
Dual Cross-Port Relief

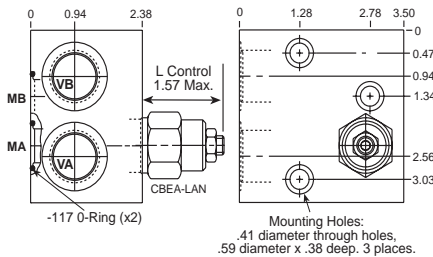
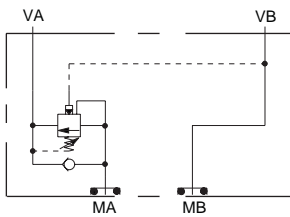

Function  
Single Counterbalance on A

Ports VA, VB  
SAE 12  
Assembly Model Code\*  
**CBEA-LAN-ZPG**

\*Add modifier **/S** to order Ductile Iron for pressure rating over 3000 psi.

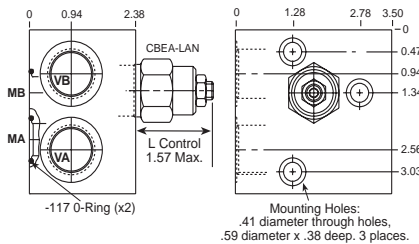
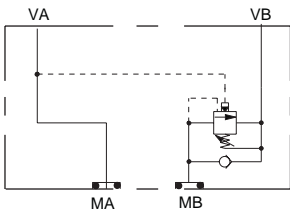

Function  
Single Counterbalance on B

Ports VA, VB  
SAE 12  
Assembly Model Code\*  
**CBEA-LAN-ZPI**

\*Add modifier **/S** to order Ductile Iron for pressure rating over 3000 psi.

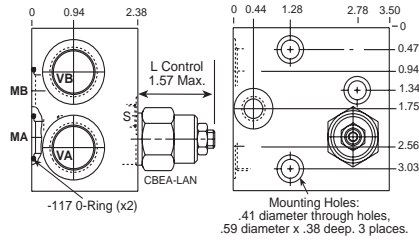
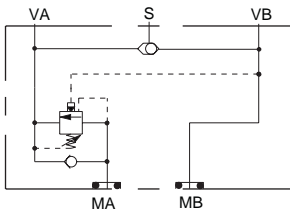

Function  
Single Counterbalance on A with Shuttle

Ports VA, VB  
SAE 12  
Assembly Model Code\*  
**CBEA-LAN-ZPM**

\*Add modifier **/S** to order Ductile Iron for pressure rating over 3000 psi.

NOTES: Page 2 for cartridge model RD\*A-\*\*\* and page 50 for CB\*\*.\* show performance curves, technical tips, and options. See page 229 for technical information about bolt-on packages.

# Standard Assemblies: Direct Motor Mounted: Char-Lynn 2000 Series Motors

## SINGLE / DUAL COUNTERBALANCE APPLICATIONS

### T-2A Cavity

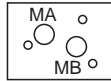

Go to [www.sunhydraulics.com](http://www.sunhydraulics.com) for more product information.

**PILOT RATIO 3:1**

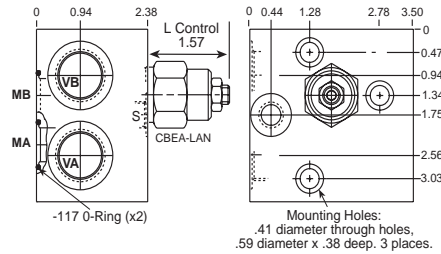
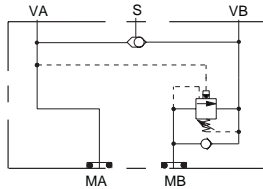

**Function**

Single Counterbalance on **B** with Shuttle

Ports  
VA, VB

Assembly  
Model Code\*

SAE 12

**CBEA-LAN-ZPO**

\*Add modifier /S to order Ductile Iron for pressure rating over 3000 psi.

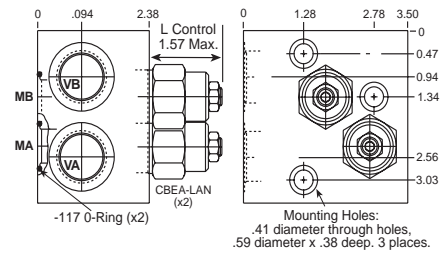
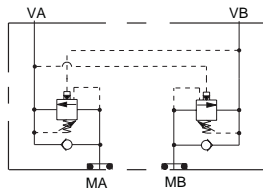

**Function**

Dual Counterbalance

Ports  
VA, VB

Assembly  
Model Code\*

SAE 12

**CBEA-LAN-YTC**

\*Add modifier /S to order Ductile Iron for pressure rating over 3000 psi.

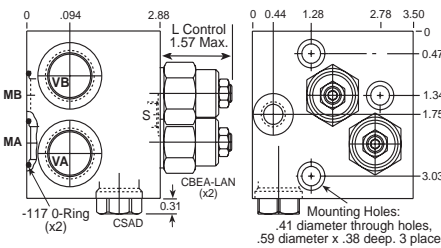
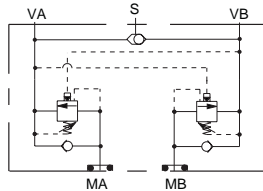

**Function**

Dual Counterbalance with Shuttle

Ports  
VA, VB

Assembly  
Model Code\*

SAE 12

**CBEA-LAN-XYX**

\*Add modifier /S to order Ductile Iron for pressure rating over 3000 psi.

NOTES: Page 50 for cartridge model CB\*\*-.\*\*\* show performance curves, technical tips, and options. See page 229 for technical information about bolt-on packages.

DUAL CROSS-PORT RELIEF AND DUAL COUNTERBALANCE APPLICATIONS

T-10A / T-2A Cavities



Go to [www.sunhydraulics.com](http://www.sunhydraulics.com) for more product information.

DIRECT ACTING

PILOT RATIOS 3:1

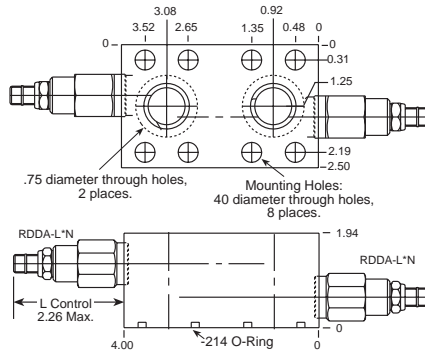
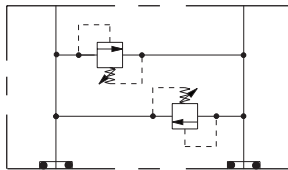

Assembly Model Code\*  
**RDDA-L\*N-YVP**

\*Add modifier /S to order Ductile Iron for pressure rating over 3000 psi.

Function  
Dual Cross-Port Relief

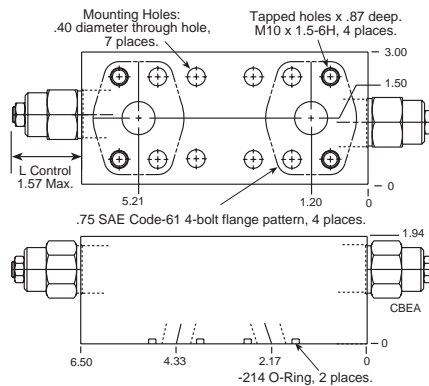
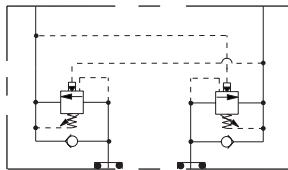

Function  
Dual Counterbalance on A and B

Ports Assembly Model Code\*  
3/4" SAE C61 **CBEA-LAN-VZX/M**

Add modifier /T to order Ductile Iron for pressure rating over 3000 psi.

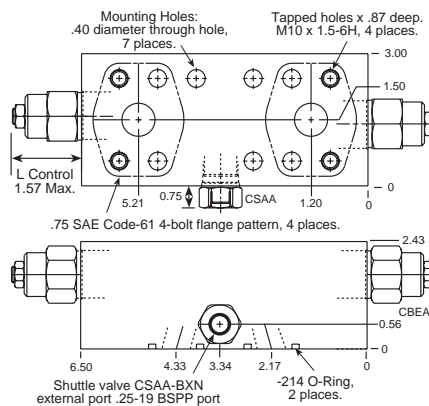
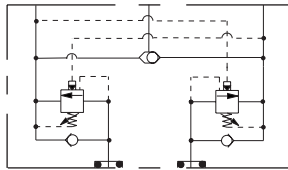

Function  
Dual Counterbalance on A and B with Shuttle

Ports Assembly Model Code\*  
3/4" SAE C61 **CBEA-LAN-VWZ**

\*Add modifier /T to order Ductile Iron for pressure rating over 3000 psi.

NOTES: Page 2 for cartridge model RD\*A-B-\*\*\* and page 50 for CB\*\*.\* show performance curves, technical tips, and options. See page 229 for technical information about bolt-on packages.

## TECHNICAL PRODUCT INFORMATION

### DIRECT MOTOR MOUNTED ASSEMBLIES

#### Danfoss (OMP/OMR Series and OMT Series)

#### *Applications*

The Danfoss gerotor type gear motor is used on a large number of mobile and industrial applications. It is often necessary to incorporate valves in the circuit with the motor to control the flow and pressure. It is also sometimes necessary to incorporate load control valves in the circuit.

It is possible to mount line-mounted valves into the pipework feeding the motor but Sun offers a large range of valves that can be bolted directly onto the motor interface. This eliminates pipework and provides the control directly at the motor.

The use of Sun cartridge valves in these valve assemblies means that in the event of a problem it is a simple task to replace the cartridge rather than have to replace the complete valve.

We are showing a range of bolt-on valve assemblies for the two most common ranges of Danfoss motors, the OMP/OMR range and the OMT range.

#### *Design Concepts and Features*

The valve assemblies shown for all sizes of motor are counterbalance valves and cross line relief valves. The counterbalance valves provide load holding and load control while the cross line relief valves provide protection from over pressurisation. The Sun counterbalance valves provide excellent control with low hysteresis and minimum leakage. The relief valves are fast acting with minimum overshoot for excellent protection.

On the smaller sizes of motor, Sun also offers flow control, which can accurately control the motor speed. The type of valve offered is a restrictor type control valve but for more accurate flow control a pressure compensated valve can also be used. Sun also has a further expanded range of bolt on valve assemblies. Consult your local Sun company or distributor for further information.



# Standard Assemblies: Direct Motor Mounted: Danfoss (OMP/OMR Series)

## SINGLE / DUAL CROSS-PORT RELIEF AND SINGLE COUNTERBALANCE APPLICATIONS

### T-10A / T-11A Cavities



Go to [www.sunhydraulics.com](http://www.sunhydraulics.com) for more product information.

#### DIRECT ACTING

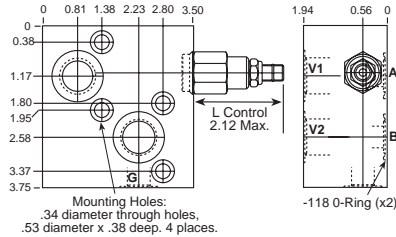
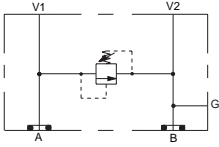

#### PILOT RATIO 3:1

#### Function

Single Cross-Port Relief **A to B**

Ports V1, V2	Gauge Port	Assembly Model Code*
SAE10	SAE-6	<b>RDDA-L*N-WVY</b>

\*Add modifier **/S** to order Ductile Iron for pressure rating over 3000 psi.

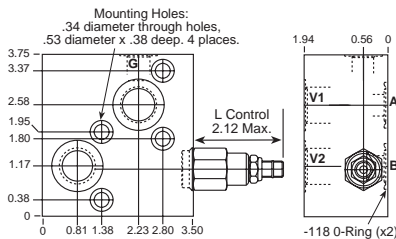
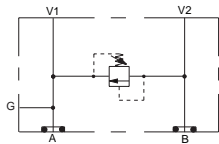

#### Function

Single Cross-Port Relief **B to A**

Ports V1, V2	Gauge Port	Assembly Model Code*
SAE10	SAE-6	<b>RDDA-L*N-WVS</b>

\*Add modifier **/S** to order Ductile Iron for pressure rating over 3000 psi.

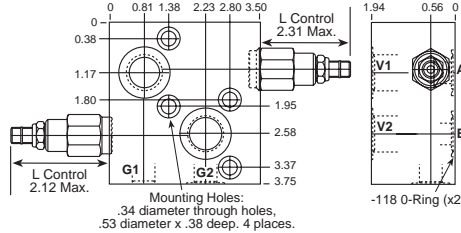
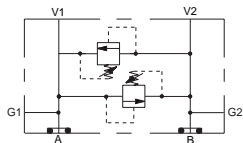

#### Function

Dual Cross-Port Relief

Ports V1, V2	Gauge Port	Assembly Model Code*
SAE10	SAE-6	<b>RDDA-L*N-WVP</b>

\*Add modifier **/S** to order Ductile Iron for pressure rating over 3000 psi.

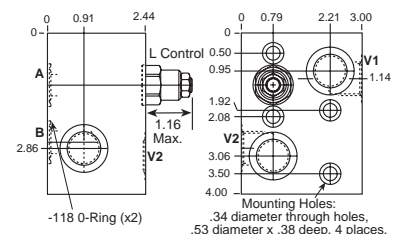
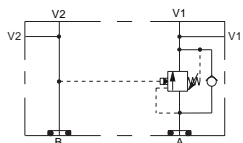

#### Function

Single Counterbalance on **A**

Ports V1, V2	Assembly Model Code*
SAE10	<b>CBCA-LAN-WZH</b>

\*Add modifier **/S** to order Ductile Iron for pressure rating over 3000 psi.

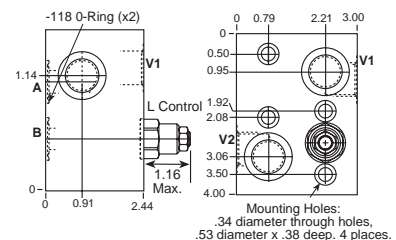
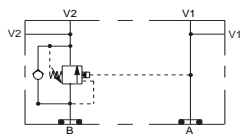

#### Function

Single Counterbalance on **B**

Ports V1, V2	Assembly Model Code*
SAE10	<b>CBCA-LAN-WZE</b>

\*Add modifier **/S** to order Ductile Iron for pressure rating over 3000 psi.

NOTES: Page 2 for cartridge models RD\*A-\*\*\* and page 50 for CB\*\*-\* show performance curves, technical tips, and options. See page 229 for technical information about bolt-on packages.

**SINGLE / DUAL COUNTERBALANCE APPLICATIONS (SHUTTLES)**

**T-11A Cavity**



Go to [www.sunhydraulics.com](http://www.sunhydraulics.com) for more product information.

**PILOT RATIO 3:1**

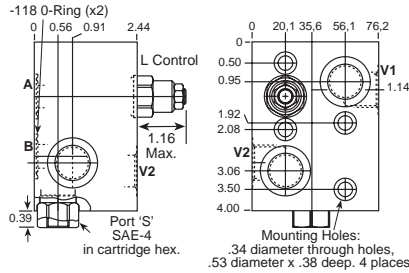
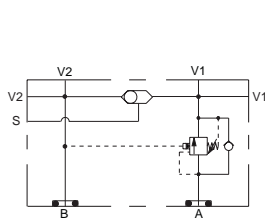

**Function**  
Single Counterbalance on A with Shuttle

Ports VI, V2	Assembly Model Code*
SAE10	<b>CBCA-LAN-WZS</b>

\*Add modifier /S to order Ductile Iron for pressure rating over 3000 psi.

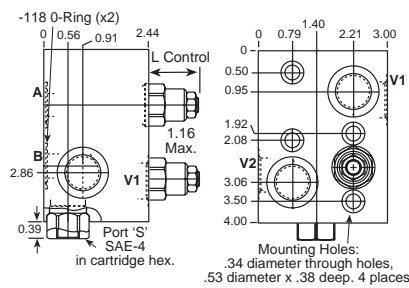
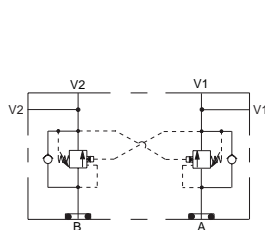

**Function**  
Single Counterbalance on B with Shuttle

Ports VI, V2	Assembly Model Code*
SAE10	<b>CBCA-LAN-WZP</b>

\*Add modifier /S to order Ductile Iron for pressure rating over 3000 psi.

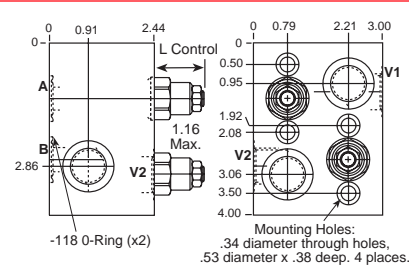
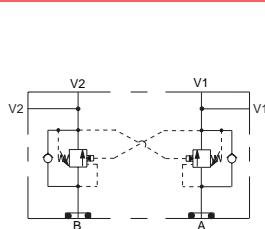

**Function**  
Dual Counterbalance

Ports VI, V2	Assembly Model Code*
SAE10	<b>CBCA-LAN-WZL</b>

\*Add modifier /S to order Ductile Iron for pressure rating over 3000 psi.

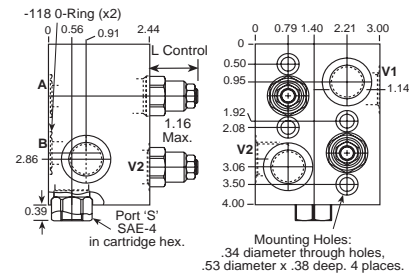
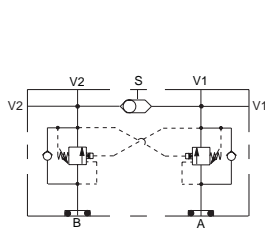

**Function**  
Dual Counterbalance with Shuttle

Ports VI, V2	Assembly Model Code*
SAE10	<b>CBCA-LAN-WZV</b>

\*Add modifier /S to order Ductile Iron for pressure rating over 3000 psi.

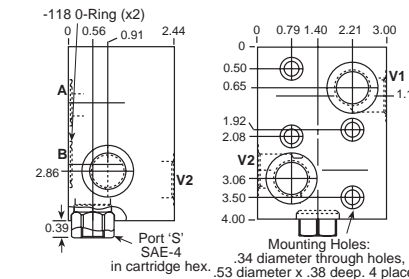
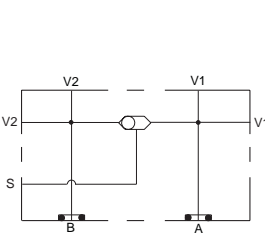

**Function**  
Shuttle Only

Ports VI, V2	Assembly Model Code*
SAE10	<b>CSAA-BXN-WZY</b>

\*Add modifier /S to order Ductile Iron for pressure rating over 3000 psi.

NOTES: Page 50 for cartridge models CB\*\*.\* show performance curves, technical tips, and options. See page 229 for technical information about bolt-on packages.

Standard Assemblies: Direct Motor Mounted: Danfoss (OMP/OMR Series)

DUAL FLOW CONTROL APPLICATIONS

T-5A Cavity



Go to [www.sunhydraulics.com](http://www.sunhydraulics.com) for more product information.

FULLY ADJUSTABLE PRESSURE COMPENSATED FLOW CONTROL WITH REVERSE FREE FLOW CHECK

Function

Dual Flow Control  
Meter-in on **A** and **B**

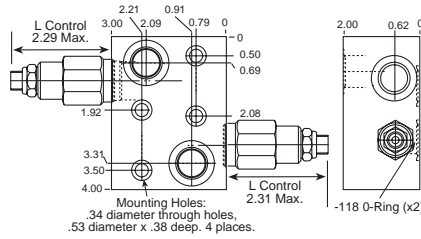
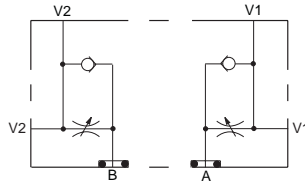

Ports  
V1, V2

Assembly  
Model Code\*

SAE10

**FDCB-LAN-WZB**

\*Add modifier /S to order Ductile Iron for pressure rating over 3000 psi.

Function

Dual Flow Control  
Meter-out on **A** and **B**

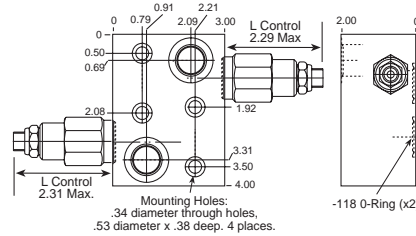
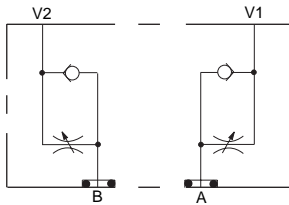

Ports  
V1, V2

Assembly  
Model Code\*

SAE10

**FDCB-LAN-WXH**

\*Add modifier /S to order Ductile Iron for pressure rating over 3000 psi.

NOTES: Page 126 for cartridge models FD\*B-\*\*\* show performance curves, technical tips, and options. See page 229 for technical information about bolt-on packages.

SINGLE / DUAL CROSS-PORT RELIEF AND SINGLE COUNTERBALANCE APPLICATIONS

T-10A / T-2A Cavities

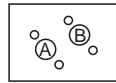

Go to [www.sunhydraulics.com](http://www.sunhydraulics.com) for more product information.

DIRECT ACTING

PILOT RATIO 3:1

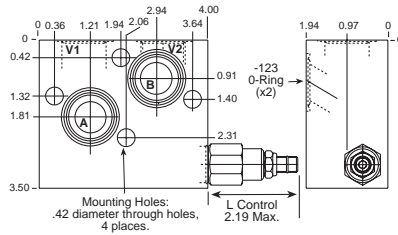
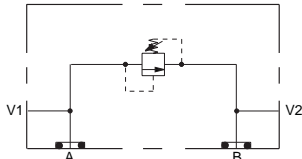

**Function**  
Single Cross-Port Relief A to B

Ports V1, V2 Assembly Model Code\*  
SAE 12 **RDDA-L\*N-WLV**

\*Add modifier /S to order Ductile Iron for pressure rating over 3000 psi.

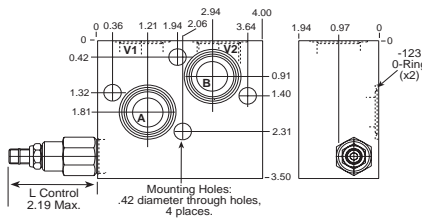
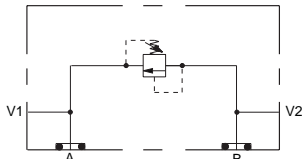

**Function**  
Single Cross-Port Relief B to A

Ports V1, V2 Assembly Model Code\*  
SAE 12 **RDDA-L\*N-WMV**

\*Add modifier /S to order Ductile Iron for pressure rating over 3000 psi.

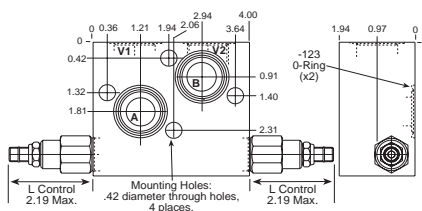
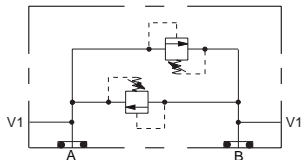

**Function**  
Dual Cross-Port Relief

Ports V1, V2 Assembly Model Code\*  
SAE 12 **RDDA-L\*N-WLV**

\*Add modifier /S to order Ductile Iron for pressure rating over 3000 psi.

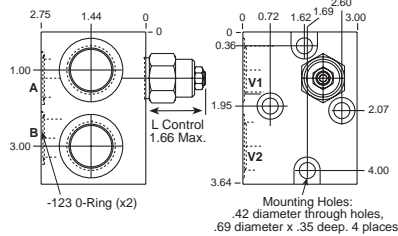
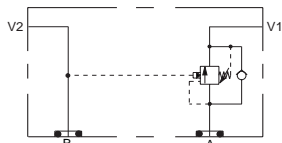

**Function**  
Single Counterbalance on A

Ports V1, V2 Assembly Model Code\*  
SAE 12 **CBEA-LAN-WKH**

\*Add modifier /S to order Ductile Iron for pressure rating over 3000 psi.

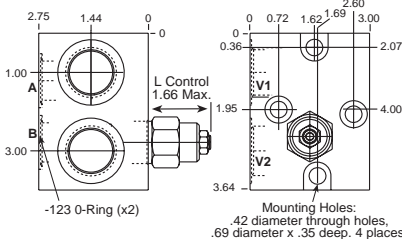
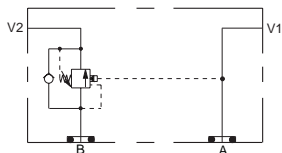

**Function**  
Single Counterbalance on B

Ports V1, V2 Assembly Model Code\*  
SAE 12 **CBEA-LAN-WKL**

\*Add modifier /S to order Ductile Iron for pressure rating over 3000 psi.

NOTES: Pages 2 for cartridge models RD\*A-\*\*\* and page 50 for CB\*-\*\*\* show performance curves, technical tips, and options. See page 229 for technical information about bolt-on packages.

Standard Assemblies: Direct Motor Mounted: Danfoss (OMT Series)

SINGLE / DUAL COUNTERBALANCE APPLICATIONS (SHUTTLES)

T-2A Cavity

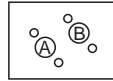

Go to [www.sunhydraulics.com](http://www.sunhydraulics.com) for more product information.

PILOT RATIO 3:1

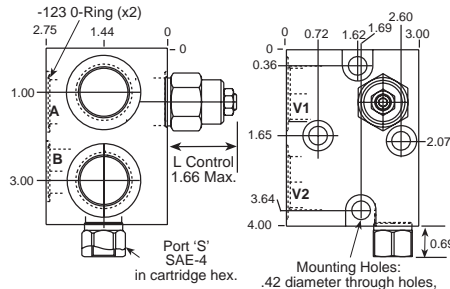
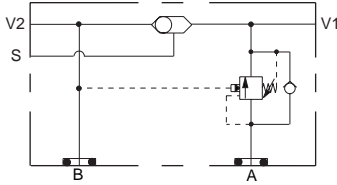

Function

Single Counterbalance on A with Shuttle

Ports V1, V2  
SAE 12

Assembly Model Code\*

**CBEA-LAN-WKP**

\*Add modifier /S to order Ductile Iron for pressure rating over 3000 psi.

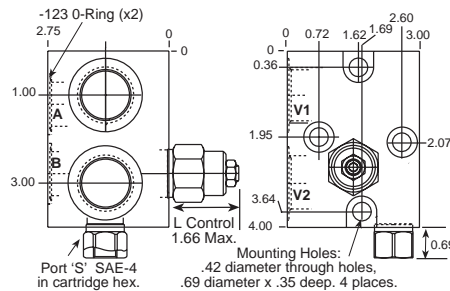
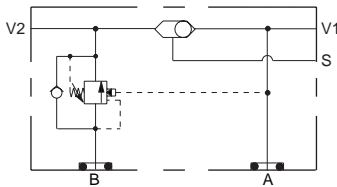

Function

Single Counterbalance on B with Shuttle

Ports V1, V2  
SAE 12

Assembly Model Code\*

**CBEA-LAN-WKS**

\*Add modifier /S to order Ductile Iron for pressure rating over 3000 psi.

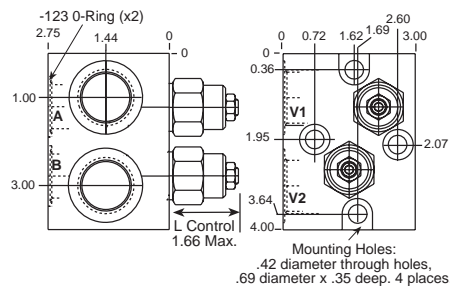
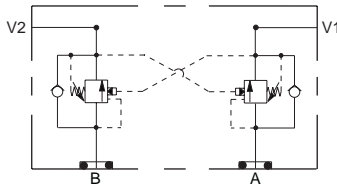

Function

Dual Counterbalance

Ports V1, V2  
SAE 12

Assembly Model Code\*

**CBEA-LAN-WKV**

\*Add modifier /S to order Ductile Iron for pressure rating over 3000 psi.

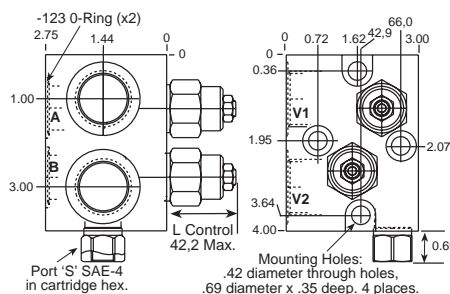
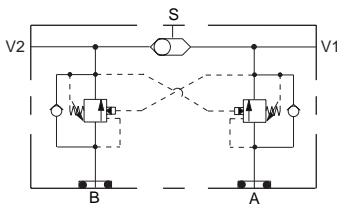

Function

Dual Counterbalance with Shuttle

Ports V1, V2  
SAE 12

Assembly Model Code\*

**CBEA-LAN-WKY**

\*Add modifier /S to order Ductile Iron for pressure rating over 3000 psi.

NOTES: Page 50 for cartridge model CB\*\*.\* show performance curves, technical tips, and options. See page 229 for technical information about bolt-on packages.