

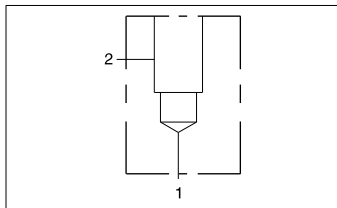

LINE MOUNT BODIES



- Aluminum rated to 3000 psi.
- Ductile Iron rated to 5000 psi.



90 degree body.

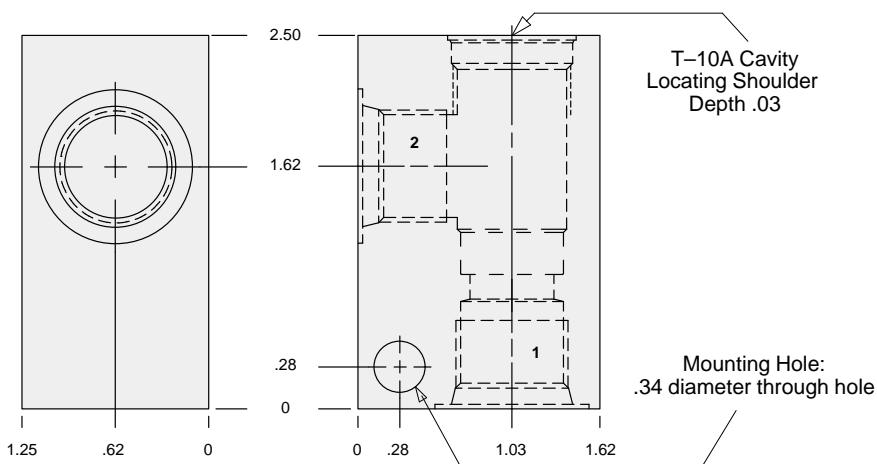

TYPICAL CARTRIDGES USED WITH THIS BODY

RPEC - ***	Page 1.06
RPEE - ***	Page 1.08
RDDA - ***	Page 1.10
RQEB - ***	Page 1.12
RBAC - ***	Page 1.16

Instructions for ordering complete cartridge and body assemblies. Page v

Pressure ratings, material specifications. Page 11.02

Ports 1 & 2	ALUMINUM		DUCTILE IRON	
	Part Number	List Price	Part Number	List Price
.25 NPTF	FAA		FAA/S	
.375 NPTF	FAB		FAB/S	
SAE-4	FAH		FAH/S	
SAE-6	FAI		FAI/S	
SAE-8	FAJ		FAJ/S	
.25 BSPP	FAT		FAT/S	
.375 BSPP	FAU		FAU/S	

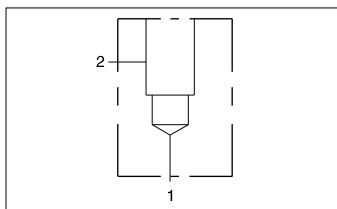

90 degree body.

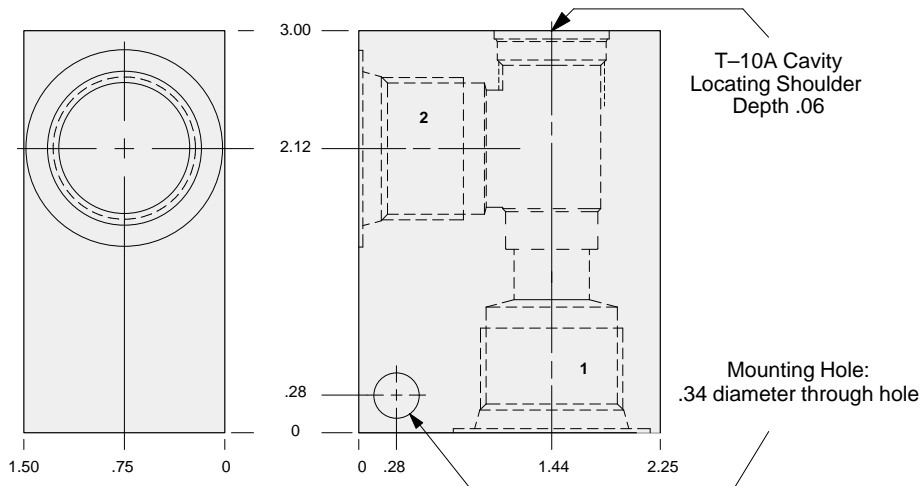

TYPICAL CARTRIDGES USED WITH THIS BODY

RPEC - ***	Page 1.06
RPEE - ***	Page 1.08
RDDA - ***	Page 1.10
RQEB - ***	Page 1.12

Instructions for ordering complete cartridge and body assemblies. Page v

Pressure ratings, material specifications. Page 11.02

Ports 1 & 2	ALUMINUM		DUCTILE IRON	
	Part Number	List Price	Part Number	List Price
.50 NPTF	FAC		FAC/S	
.75 NPTF	FAD		FAD/S	
SAE-10	FAK		FAK/S	
SAE-12	FAL		FAL/S	
.50 BSPP	FAV		FAV/S	
.75 BSPP	FAW		FAW/S	

S1
T10A



LINE MOUNT BODIES



- Aluminum rated to 3000 psi.
- Ductile Iron rated to 5000 psi.

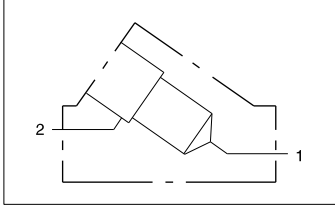

Inline body.

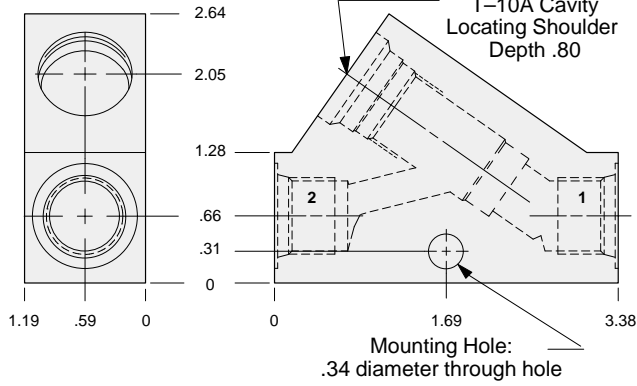

TYPICAL CARTRIDGES USED WITH THIS BODY

RPEC - ***	Page 1.06
RPEE - ***	Page 1.08
RDDA - ***	Page 1.10
RQEB - ***	Page 1.12
RBAC - ***	Page 1.16

Instructions for ordering complete cartridge and body assemblies. Page v

Pressure ratings, material specifications. Page 11.02

Ports 1 & 2	ALUMINUM		DUCTILE IRON	
	Part Number	List Price	Part Number	List Price
.25 NPTF	FCA		FCA/S	
.375 NPTF	FCB		FCB/S	
.50 NPTF	FCC		FCC/S	
SAE-4	FCH		FCH/S	
SAE-6	FCI		FCI/S	
SAE-8	FCJ		FCJ/S	
.25 BSPP	FCT		FCT/S	
.375 BSPP	FCU		FCU/S	
.50 BSPP	FCV		FCV/S	



LINE MOUNT BODIES



- Aluminum rated to 3000 psi.
- Ductile Iron rated to 5000 psi.

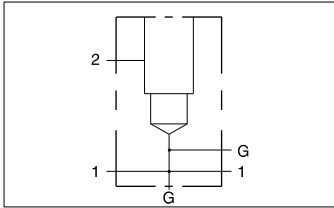

TYPICAL CARTRIDGES USED WITH THIS BODY

RPEC - ***	Page 1.06
RPEE - ***	Page 1.08
RDDA - ***	Page 1.10
RQEB - ***	Page 1.12
RBAC - ***	Page 1.16

Instructions for ordering complete cartridge and body assemblies. Page v

Pressure ratings, material specifications. Page 11.02

Through port body with gage port.

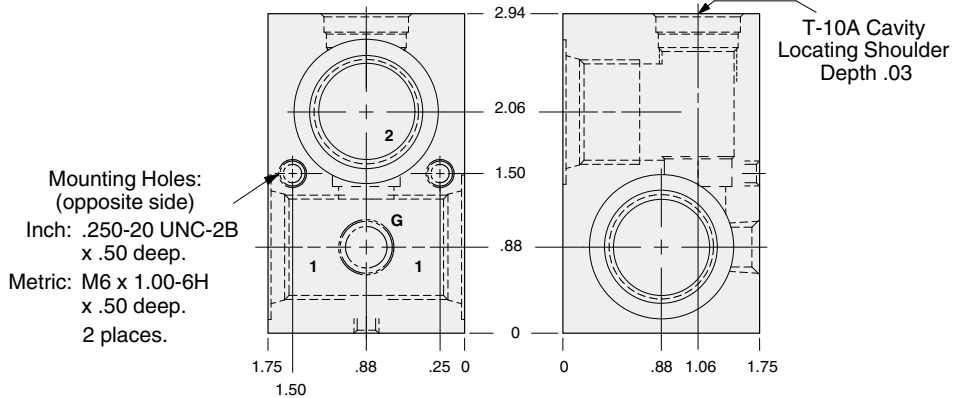

Mounting Hole Dimensions	Ports 1 & 2	Gage Port	ALUMINUM		DUCTILE IRON	
			Part Number	List Price	Part Number	List Price
Inch .25 NPTF	.25 NPTF	.25 NPTF	FEA		FEA/S	
Inch .375 NPTF	.375 NPTF	.25 NPTF	FEB		FEB/S	
Inch .50 NPTF	.50 NPTF	.25 NPTF	FEC		FEC/S	
Inch SAE-6	SAE-6	.25 NPTF	FEI		FEI/S	
Inch SAE-8	SAE-8	.25 NPTF	FEJ		FEJ/S	
Inch SAE-10	SAE-10	.25 NPTF	FEK		FEK/S	
Metric .25 BSPP	.25 BSPP	.25 BSPP	FET		FET/S	
Metric .375 BSPP	.375 BSPP	.25 BSPP	FEU		FEU/S	
Metric .50 BSPP	.50 BSPP	.25 BSPP	FEV		FEV/S	

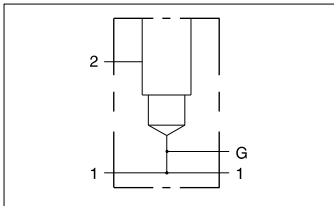

TYPICAL CARTRIDGES USED WITH THIS BODY

RPEC - ***	Page 1.06
RPEE - ***	Page 1.08
RDDA - ***	Page 1.10
RQEB - ***	Page 1.12

Instructions for ordering complete cartridge and body assemblies. Page v

Pressure ratings, material specifications. Page 11.02

Through port body with gage port.

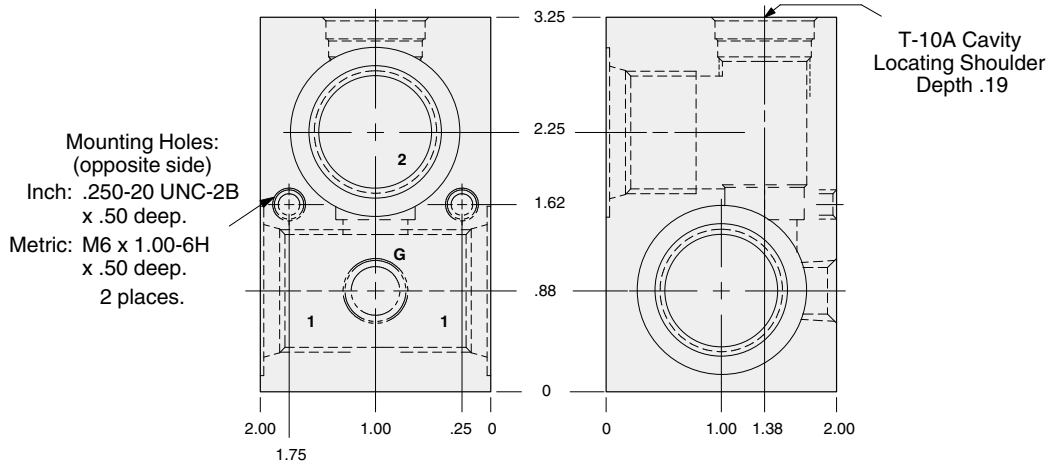

Mounting Hole Dimensions	Ports 1 & 2	Gage Port	ALUMINUM		DUCTILE IRON	
			Part Number	List Price	Part Number	List Price
Inch .75 NPTF	.75 NPTF	.25 NPTF	FED		FED/S	
Inch SAE-12	SAE-12	.25 NPTF	FEL		FEL/S	
Metric .75 BSPP	.75 BSPP	.25 BSPP	FEW		FEW/S	

S1
T10A



LINE MOUNT BODIES



- Aluminum rated to 3000 psi.
- Ductile Iron rated to 5000 psi.

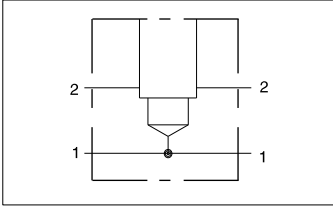

Dual through port body.

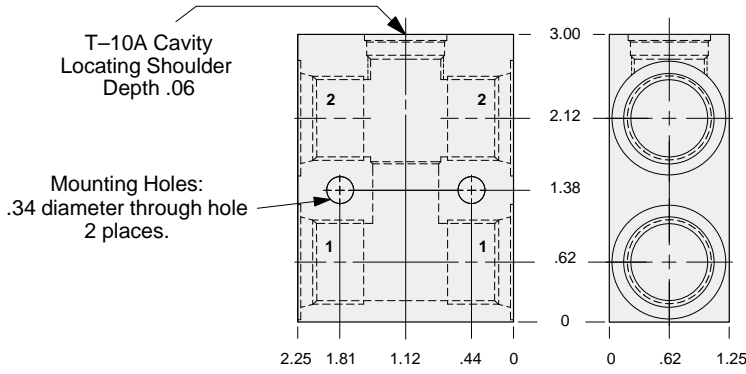

TYPICAL CARTRIDGES USED WITH THIS BODY

RPEC - ***	Page 1.06
RPEE - ***	Page 1.08
RDDA - ***	Page 1.10
RQEB - ***	Page 1.12
RBAC - ***	Page 1.16

Instructions for ordering complete cartridge and body assemblies. Page v

Pressure ratings, material specifications. Page 11.02

Ports 1 & 2	ALUMINUM		DUCTILE IRON	
	Part Number	List Price	Part Number	List Price
.25 NPTF	WNR		WNR/S	
.375 NPTF	WNS		WNS/S	
.50 NPTF	WNT		WNT/S	
SAE-6	WNU		WNU/S	
SAE-8	WNV		WNV/S	
SAE-10	WNW		WNW/S	
.25 BSPP	WNX		WNX/S	
.375 BSPP	WNY		WNY/S	
.50 BSPP	WNZ		WNZ/S	



LINE MOUNT BODIES



- Aluminum rated to 3000 psi.
- Ductile Iron rated to 5000 psi.

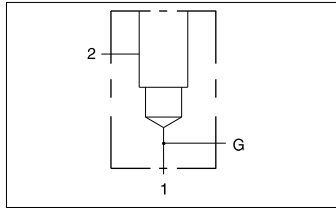

90 degree .75" SAE Code 61 flange port body with gage port.

TYPICAL CARTRIDGES USED WITH THIS BODY

RPEC - ***	Page 1.06
RPEE - ***	Page 1.08
RDDA - ***	Page 1.10
RQEB - ***	Page 1.12

Instructions for ordering complete cartridge and body assemblies. Page v

Pressure ratings, material specifications. Page 11.02

SAE Specifications Page 11.03

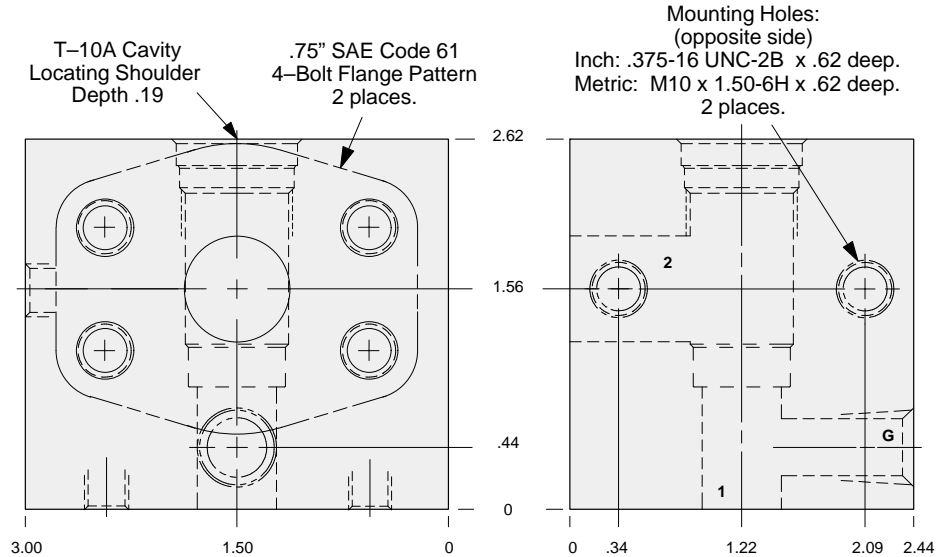

Mounting Hole Dimensions	Gage Port	ALUMINUM		DUCTILE IRON	
		Part Number	List Price	Part Number	List Price
Inch	.25 NPTF	FAO		FAO/S	
Metric	.25 BSPP	FAO/M		FAO/T	

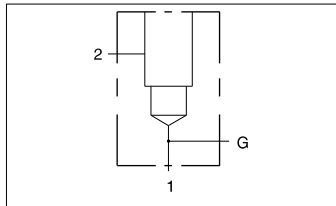

90 degree .75" SAE Code 62 flange port body with gage port.

TYPICAL CARTRIDGES USED WITH THIS BODY

RPEC - ***	Page 1.06
RPEE - ***	Page 1.08
RDDA - ***	Page 1.10
RQEB - ***	Page 1.12

Instructions for ordering complete cartridge and body assemblies. Page v

Pressure ratings, material specifications. Page 11.02

SAE Specifications Page 11.03

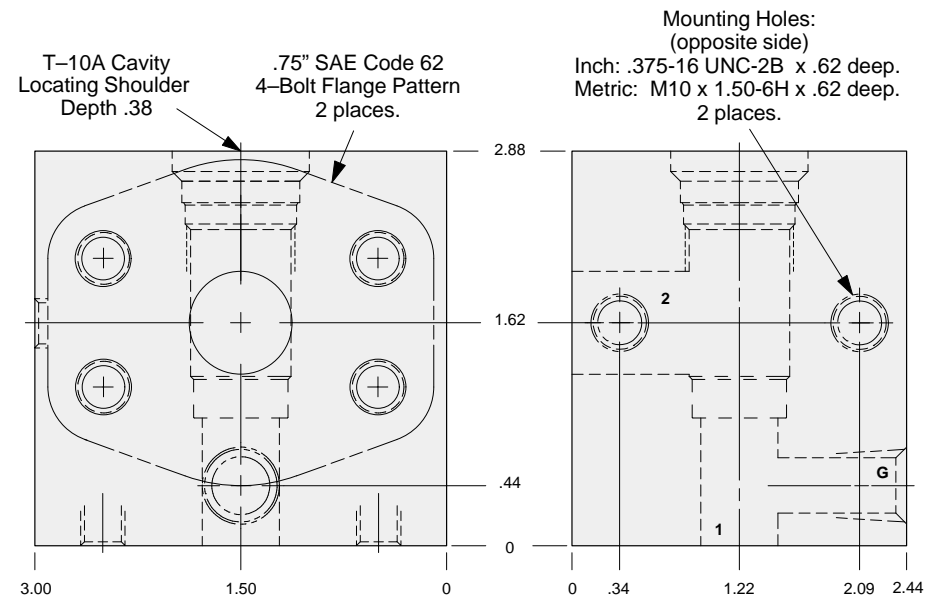

Mounting Hole Dimensions	Gage Port	ALUMINUM		DUCTILE IRON	
		Part Number	List Price	Part Number	List Price
Inch	.25 NPTF	FA3		FA3/S	
Metric	.25 BSPP	FA3/M		FA3/T	

S1
T10A



LINE MOUNT BODIES



- Aluminum rated to 3000 psi.
- Ductile Iron rated to 5000 psi.

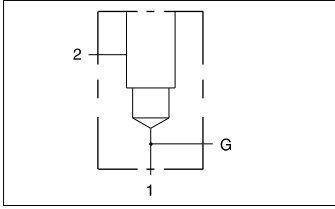

90 degree 1.00" SAE Code 61 flange port body with gage port.

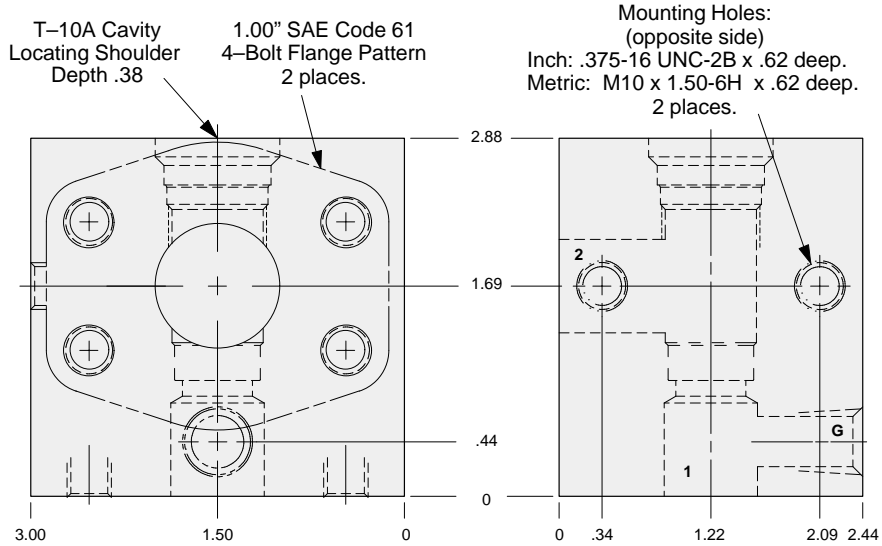

TYPICAL CARTRIDGES USED WITH THIS BODY

- RPEC - *** Page 1.06
- RPEE - *** Page 1.08
- RDDA - *** Page 1.10
- RQEB - *** Page 1.12

Instructions for ordering complete cartridge and body assemblies. Page v

Pressure ratings, material specifications. Page 11.02

SAE Specifications Page 11.03

Mounting Hole Dimensions	Gage Port	ALUMINUM		DUCTILE IRON	
		Part Number	List Price	Part Number	List Price
Inch	.25 NPTF	FAP		FAP/S	
Metric	.25 BSPP	FAP/M		FAP/T	

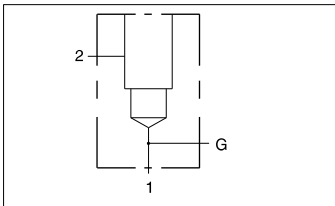

90 degree 1.00" SAE Code 62 flange port body with gage port.

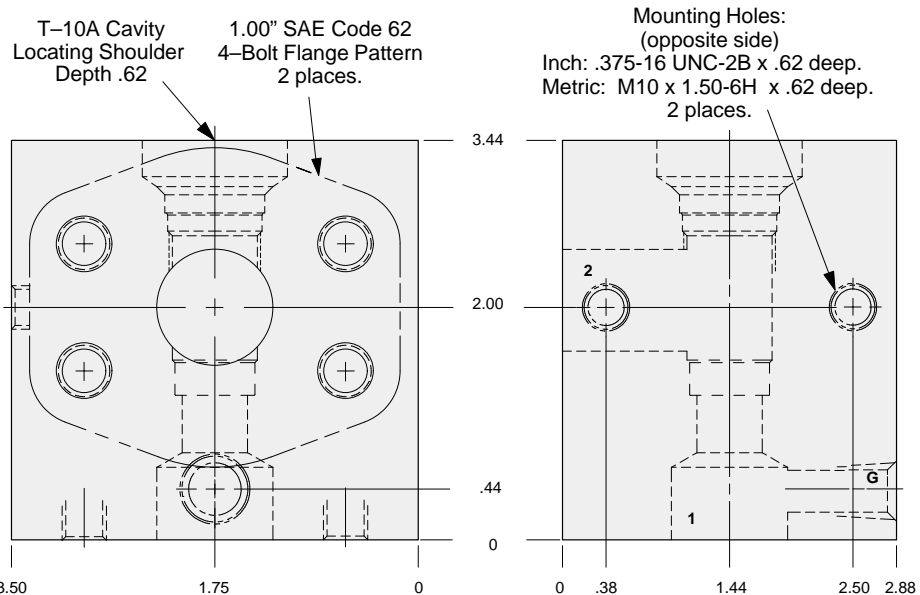

TYPICAL CARTRIDGES USED WITH THIS BODY

- RPEC - *** Page 1.06
- RPEE - *** Page 1.08
- RDDA - *** Page 1.10
- RQEB - *** Page 1.12

Instructions for ordering complete cartridge and body assemblies. Page v

Pressure ratings, material specifications. Page 11.02

SAE Specifications Page 11.03

Mounting Hole Dimensions	Gage Port	ALUMINUM		DUCTILE IRON	
		Part Number	List Price	Part Number	List Price
Inch	.25 NPTF	FA4		FA4/S	
Metric	.25 BSPP	FA4/M		FA4/T	

S1
T10A



LINE MOUNT BODIES



- Aluminum rated to 3000 psi.
- Ductile Iron rated to 5000 psi.

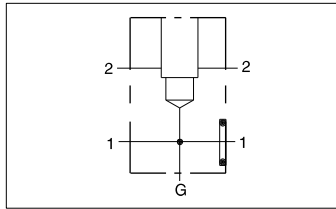

TYPICAL CARTRIDGES USED WITH THIS BODY

- RPEC - *** Page 1.06
- RPEE - *** Page 1.08
- RDDA - *** Page 1.10
- RQEB - *** Page 1.12

Cartridge seal type determines O-ring type.

Instructions for ordering complete cartridge and body assemblies. Page v

Pressure ratings, material specifications. Page 11.02

SAE Specifications Page 11.03

Sandwich mount through port .75" SAE Code 61 body with gage port.

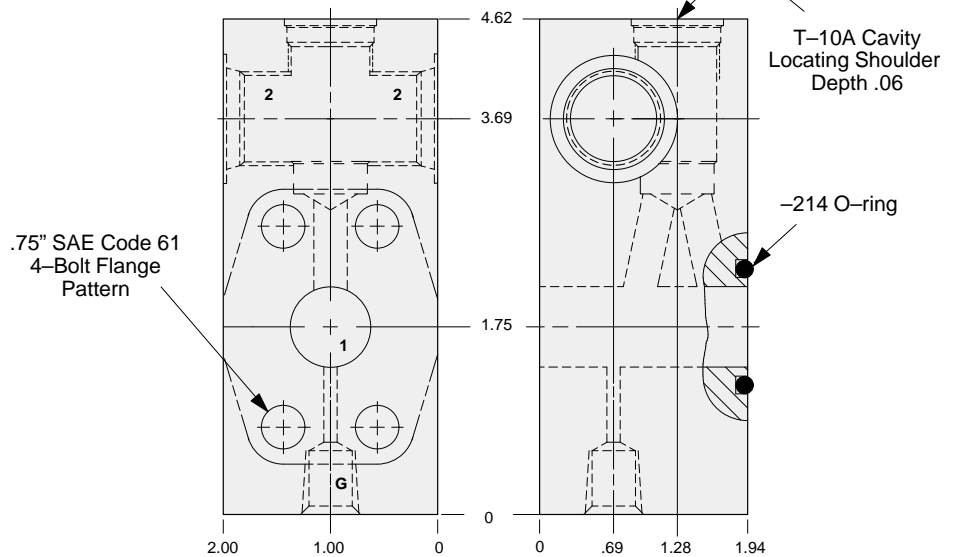

Mounting Hole Dimensions	Port 2	Gage Port	ALUMINUM		DUCTILE IRON	
			Part Number	List Price	Part Number	List Price
Inch	SAE-10	.25 NPTF	ZQN		ZQN/S	
Metric	.50 BSPP	.25 BSPP	ZQM		ZQM/S	

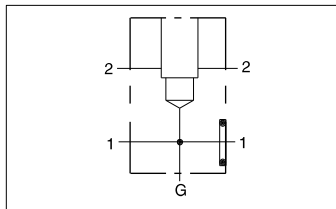

TYPICAL CARTRIDGES USED WITH THIS BODY

- RPEC - *** Page 1.06
- RPEE - *** Page 1.08
- RDDA - *** Page 1.10
- RQEB - *** Page 1.12

Cartridge seal type determines O-ring type.

Instructions for ordering complete cartridge and body assemblies. Page v

Pressure ratings, material specifications. Page 11.02

SAE Specifications Page 11.03

Flange mount through port .75" SAE Code 61 body with threaded outlet and gage port.

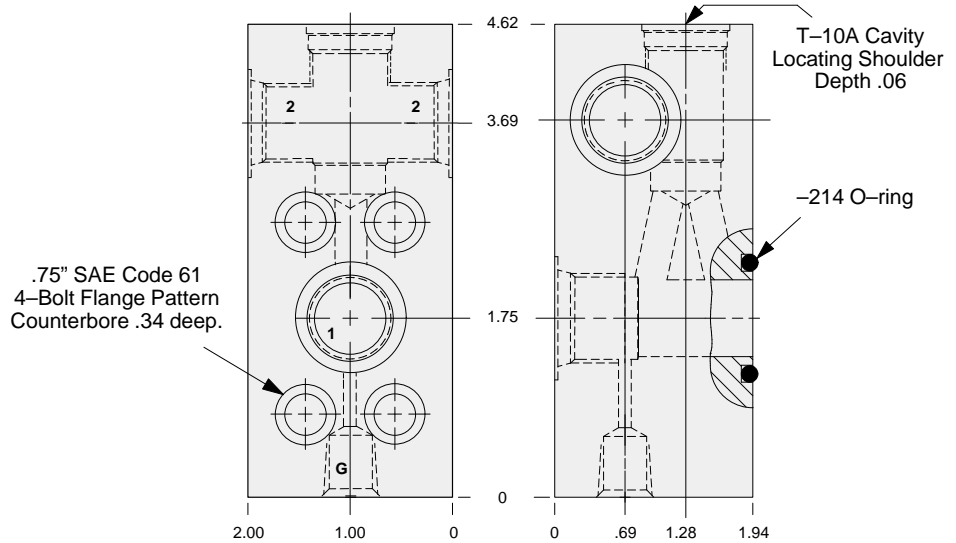

Mounting Hole Dimensions	Ports 1 & 2	Gage Port	ALUMINUM		DUCTILE IRON	
			Part Number	List Price	Part Number	List Price
Inch	SAE-10	.25 NPTF	ZDG		ZDG/S	
Inch	.50 NPTF	.25 NPTF	ZDJ		ZDJ/S	
Metric	.50 BSPP	.25 BSPP	ZDD		ZDD/S	

S1
T10A



LINE MOUNT BODIES



- Aluminum rated to 3000 psi.
- Ductile Iron rated to 5000 psi.

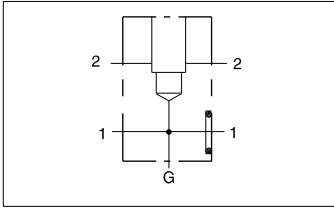

Sandwich mount through port .75" SAE Code 61 body with gage port.

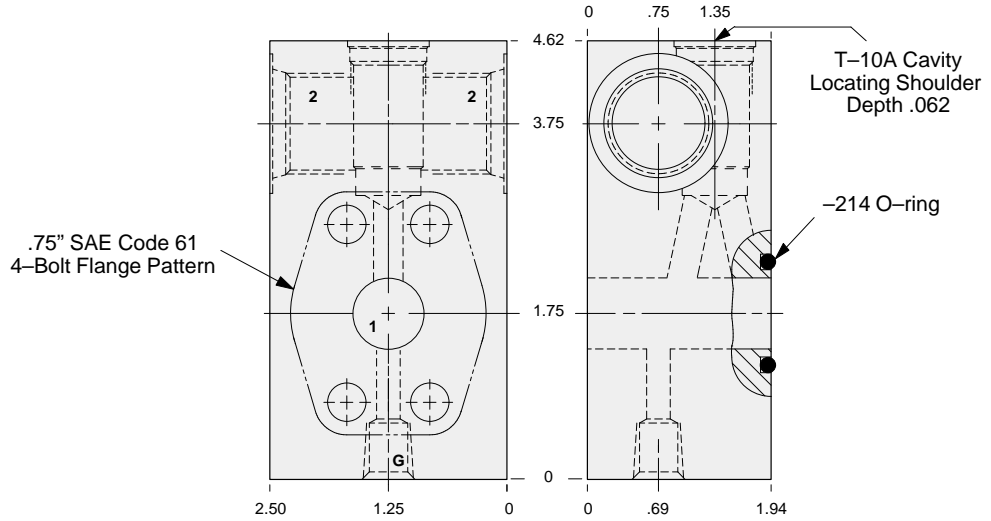

TYPICAL CARTRIDGES USED WITH THIS BODY

- RPEC - *** Page 1.06
- RPEE - *** Page 1.08
- RDDA - *** Page 1.10
- RQEB - *** Page 1.12

Cartridge seal type determines O-ring type.

Instructions for ordering complete cartridge and body assemblies. Page v

Pressure ratings, material specifications. Page 11.02

SAE Specifications Page 11.03

Mounting Hole Dimensions	Port 2	Gage Port	ALUMINUM		DUCTILE IRON	
			Part Number	List Price	Part Number	List Price
Inch	SAE-12	.25 NPTF	ZHB		ZHB/S	
Inch	.75 NPTF	.25 NPTF	ZHC		ZHC/S	
Metric	.75 BSPP	.25 BSPP	ZGZ		ZGZ/S	

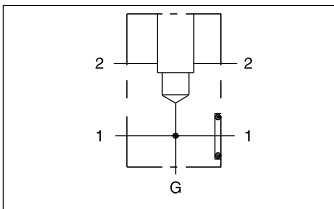

Sandwich mount through port .75" SAE Code 62 body with gage port.

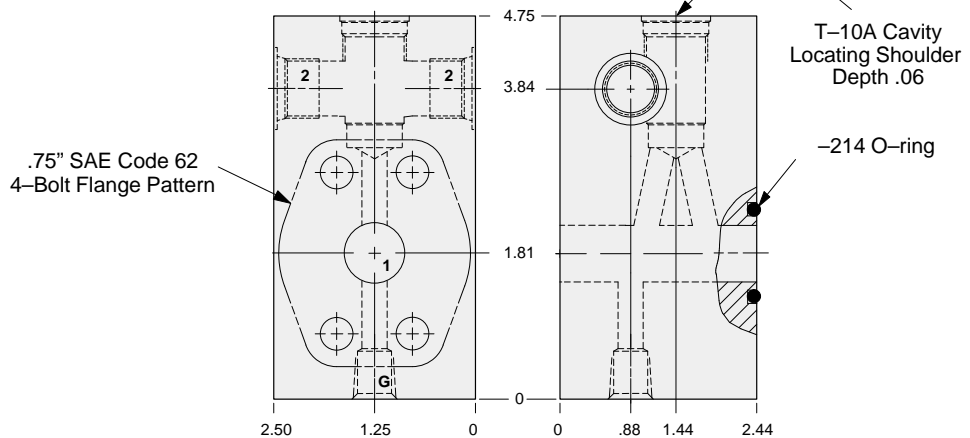

TYPICAL CARTRIDGES USED WITH THIS BODY

- RPEC - *** Page 1.06
- RPEE - *** Page 1.08
- RDDA - *** Page 1.10
- RQEB - *** Page 1.12

Cartridge seal type determines O-ring type.

Instructions for ordering complete cartridge and body assemblies. Page v

Pressure ratings, material specifications. Page 11.02

SAE Specifications Page 11.03

Mounting Hole Dimensions	Port 2	Gage Port	ALUMINUM		DUCTILE IRON	
			Part Number	List Price	Part Number	List Price
Inch	SAE-12	.25 NPTF	ZCW		ZCW/S	
Inch	SAE-10	.25 NPTF	ZCX		ZCX/S	
Inch	.75 NPTF	.25 NPTF	ZCY		ZCY/S	
Inch	.50 NPTF	.25 NPTF	ZCZ		ZCZ/S	
Metric	.75 BSPP	.25 BSPP	ZCT		ZCT/S	
Metric	.50 BSPP	.25 BSPP	ZCV/M		ZCV/T	

S1
T10A



LINE MOUNT BODIES



- Aluminum rated to 3000 psi.
- Ductile Iron rated to 5000 psi.

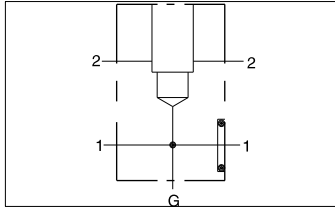

TYPICAL CARTRIDGES USED WITH THIS BODY

- RPEC - *** Page 1.06
- RPEE - *** Page 1.08
- RDDA - *** Page 1.10
- RQEB - *** Page 1.12

Cartridge seal type determines O-ring type.

Instructions for ordering complete cartridge and body assemblies. Page v

Pressure ratings, material specifications. Page 11.02

SAE Specifications Page 11.03

Flange mount through port .75" SAE Code 61 body with threaded outlet and gage port.

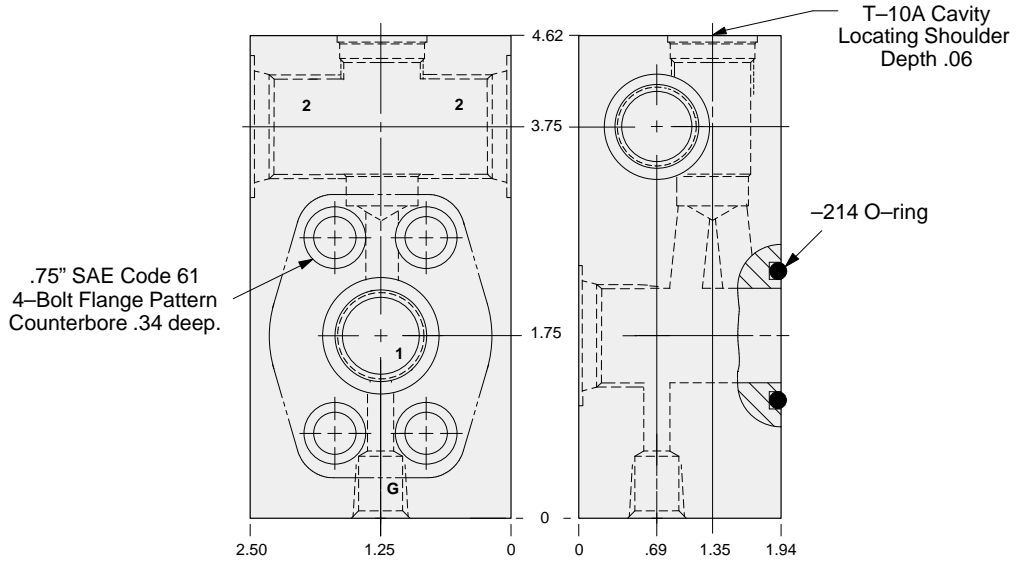

Mounting Hole Dimensions	Ports 1 & 2	Gage Port	ALUMINUM		DUCTILE IRON	
			Part Number	List Price	Part Number	List Price
Inch	SAE-12	.25 NPTF	ZDF		ZDF/S	
Inch	.75 NPTF	.25 NPTF	ZDH		ZDH/S	
Metric	.75 BSPP	.25 BSPP	ZDC		ZDC/S	

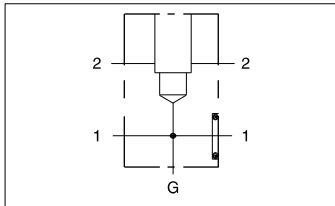

TYPICAL CARTRIDGES USED WITH THIS BODY

- RPEC - *** Page 1.06
- RPEE - *** Page 1.08
- RDDA - *** Page 1.10
- RQEB - *** Page 1.12

Cartridge seal type determines O-ring type.

Instructions for ordering complete cartridge and body assemblies. Page v

Pressure ratings, material specifications. Page 11.02

SAE Specifications Page 11.03

Flange mount through port .75" SAE Code 62 body with threaded outlet and gage port.

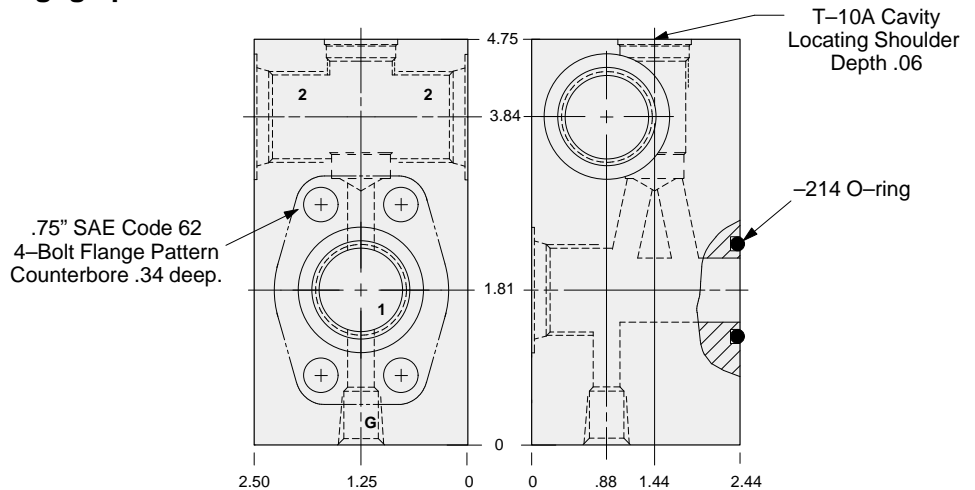

Mounting Hole Dimensions	Ports 1 & 2	Gage Port	ALUMINUM		DUCTILE IRON	
			Part Number	List Price	Part Number	List Price
Inch	SAE-12	.25 NPTF	ZCP		ZCP/S	
Inch	SAE-10	.25 NPTF	ZCQ		ZCQ/S	
Inch	.75 NPTF	.25 NPTF	ZCR		ZCR/S	
Inch	.50 NPTF	.25 NPTF	ZCS		ZCS/S	
Metric	.75 BSPP	.25 BSPP	ZCM		ZCM/S	
Metric	.50 BSPP	.25 BSPP	ZCN		ZCN/S	

S1
T10A



LINE MOUNT BODIES



- Aluminum rated to 3000 psi.
- Ductile Iron rated to 5000 psi.

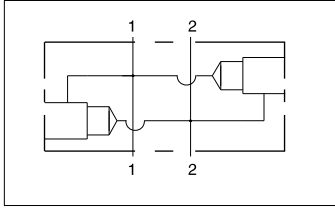

TYPICAL CARTRIDGES USED WITH THIS BODY

RPEC - ***	Page 1.06
RPEE - ***	Page 1.08
RDDA - ***	Page 1.10
RQEB - ***	Page 1.12

Instructions for ordering complete cartridge and body assemblies. Page v

Pressure ratings, material specifications. Page 11.02

Two cavity body for cross-port relief applications.

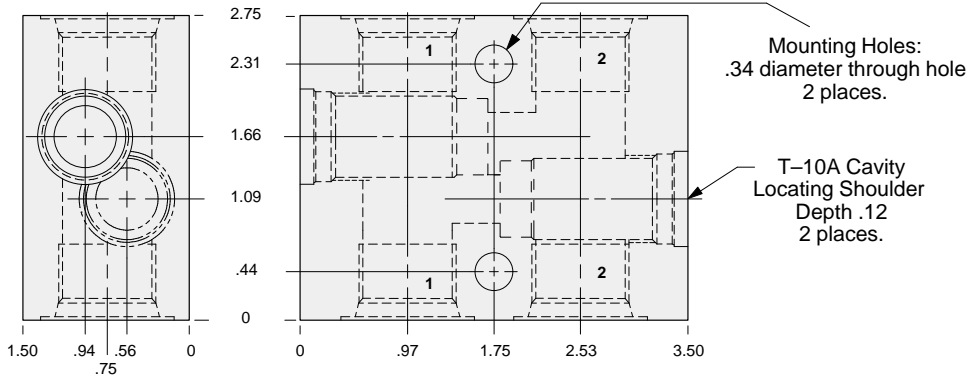

Ports 1 & 2	ALUMINUM		DUCTILE IRON	
	Part Number	List Price	Part Number	List Price
.25 NPTF	YFA		YFA/S	
.375 NPTF	YFB		YFB/S	
.50 NPTF	YFC		YFC/S	
SAE-4	YFH		YFH/S	
SAE-6	YFI		YFI/S	
SAE-8	YFJ		YFJ/S	
SAE-10	YFK		YFK/S	
.25 BSPP	YFT		YFT/S	
.375 BSPP	YFU		YFU/S	
.50 BSPP	YFV		YFV/S	

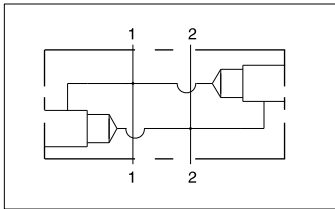

TYPICAL CARTRIDGES USED WITH THIS BODY

RPEC - ***	Page 1.06
RPEE - ***	Page 1.08
RDDA - ***	Page 1.10
RQEB - ***	Page 1.12

Instructions for ordering complete cartridge and body assemblies. Page v

Pressure ratings, material specifications. Page 11.02

Two cavity body for cross-port relief applications.

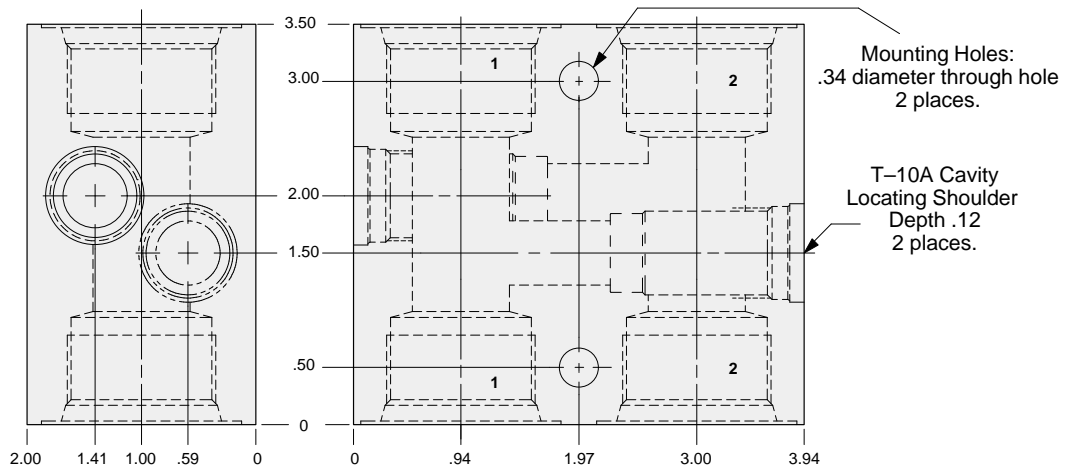

Ports 1 & 2	ALUMINUM		DUCTILE IRON	
	Part Number	List Price	Part Number	List Price
.75 NPTF	YFD		YFD/S	
1.00 NPTF	YFE		YFE/S	
SAE-12	YFL		YFL/S	
SAE-16	YFM		YFM/S	
.75 BSPP	YFW		YFW/S	
1.00 BSPP	YFX		YFX/S	



LINE MOUNT BODIES



- Aluminum rated to 3000 psi.
- Ductile Iron rated to 5000 psi.

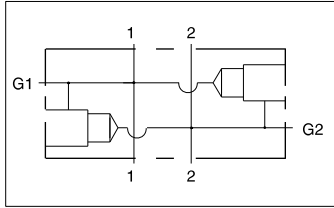

Two cavity .75" SAE Code 61 flange port body for cross-port relief applications.

TYPICAL CARTRIDGES USED WITH THIS BODY

- RPEC - *** Page 1.06
- RPEE - *** Page 1.08
- RDDA - *** Page 1.10
- RQEB - *** Page 1.12

Instructions for ordering complete cartridge and body assemblies. Page v

Pressure ratings, material specifications. Page 11.02

SAE Specifications Page 11.03

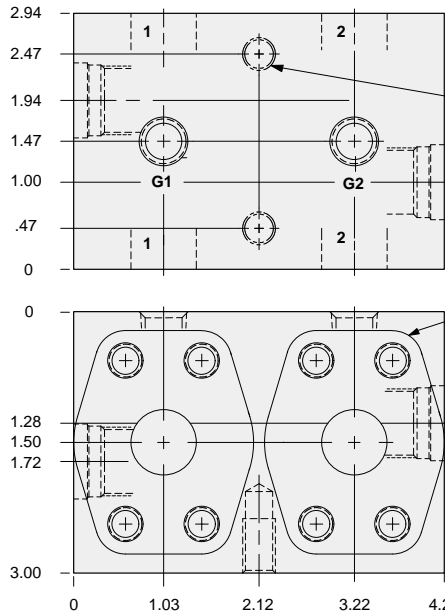

Mounting Holes:
(opposite side)
Inch: .375-16 UNC-2B x .62 deep
Metric: M10 x 1.50-6H x .62 deep
2 places.

.75" SAE Code 61
4-Bolt Flange Pattern
4 places.

T-10A Cavity
Locating Shoulder
Depth .16
2 places.

Mounting Hole Dimensions	Ports G1 & G2	ALUMINUM		DUCTILE IRON	
		Part Number	List Price	Part Number	List Price
Inch	.25 NPTF	YFO		YFO/S	
Metric	.25 BSPP	YFO/M		YFO/T	

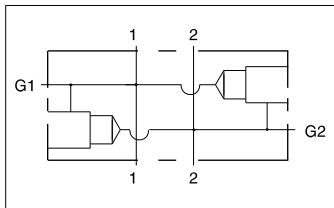

Two cavity .75" SAE Code 62 flange port body for cross-port relief applications.

TYPICAL CARTRIDGES USED WITH THIS BODY

- RPEC - *** Page 1.06
- RPEE - *** Page 1.08
- RDDA - *** Page 1.10
- RQEB - *** Page 1.12

Instructions for ordering complete cartridge and body assemblies. Page v

Pressure ratings, material specifications. Page 11.02

SAE Specifications Page 11.03

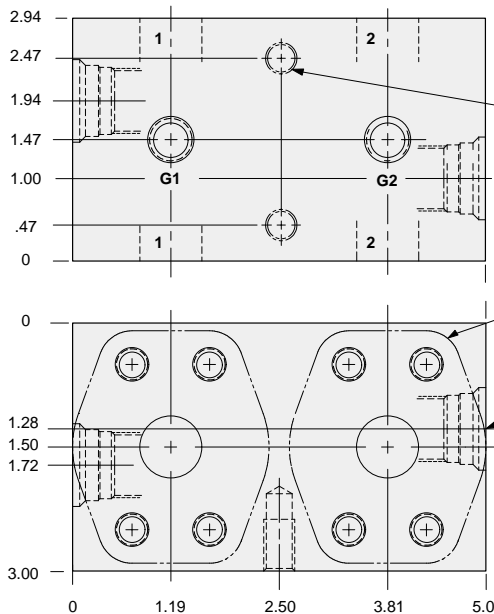

Mounting Holes:
(opposite side)
Inch: .375-16 UNC-2B x .62 deep
Metric: M10 x 1.50-6H x .62 deep
2 places.

.75" SAE Code 62
4-Bolt Flange Pattern
4 places.

T-10A Cavity
Locating Shoulder
Depth .31
2 places.

Mounting Hole Dimensions	Ports G1 & G2	ALUMINUM		DUCTILE IRON	
		Part Number	List Price	Part Number	List Price
Inch	.25 NPTF	YF3		YF3/S	
Metric	.25 BSPP	YF3/M		YF3/T	

S1
T10A



LINE MOUNT BODIES

- Aluminum rated to 3000 psi.
- Ductile Iron rated to 5000 psi.

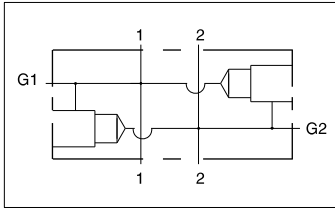

Two cavity 1.00" SAE Code 61 flange port body with gage port for cross-port relief applications.

TYPICAL CARTRIDGES USED WITH THIS BODY

- RPEC - *** Page 1.06
- RPEE - *** Page 1.08
- RDDA - *** Page 1.10
- RQEB - *** Page 1.12

Instructions for ordering complete cartridge and body assemblies. Page v

Pressure ratings, material specifications. Page 11.02

SAE Specifications Page 11.03

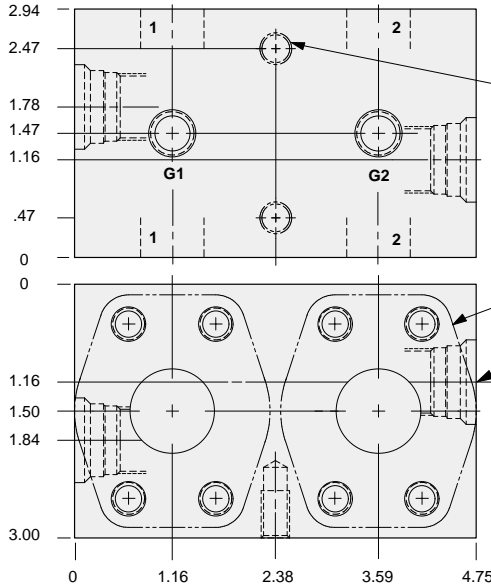

Mounting Hole Dimensions	Ports G1 & G2	ALUMINUM		DUCTILE IRON	
		Part Number	List Price	Part Number	List Price
Inch	.25 NPTF	YFP		YFP/S	
Metric	.25 BSPP	YFP/M		YFP/T	

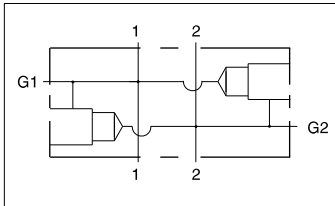

Two cavity 1.00" SAE Code 62 flange port body with gage port for cross-port relief applications.

TYPICAL CARTRIDGES USED WITH THIS BODY

- RPEC - *** Page 1.06
- RPEE - *** Page 1.08
- RDDA - *** Page 1.10
- RQEB - *** Page 1.12

Instructions for ordering complete cartridge and body assemblies. Page v

Pressure ratings, material specifications. Page 11.02

SAE Specifications Page 11.03

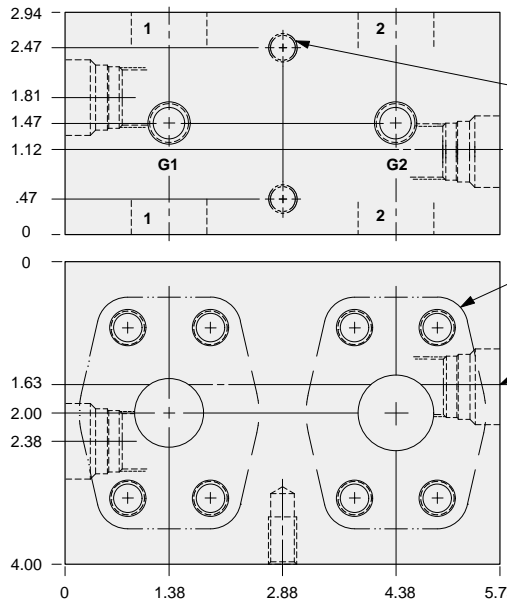

Mounting Hole Dimensions	Ports G1 & G2	ALUMINUM		DUCTILE IRON	
		Part Number	List Price	Part Number	List Price
Inch	.25 NPTF	YF4		YF4/S	
Metric	.25 BSPP	YF4/M		YF4/T	

S1
T10A



LINE MOUNT BODIES



- Aluminum rated to 3000 psi.
- Ductile Iron rated to 5000 psi.

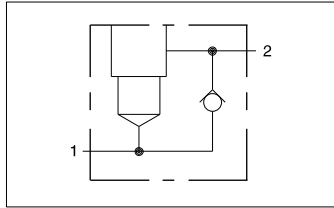

Body with reverse free flow check.

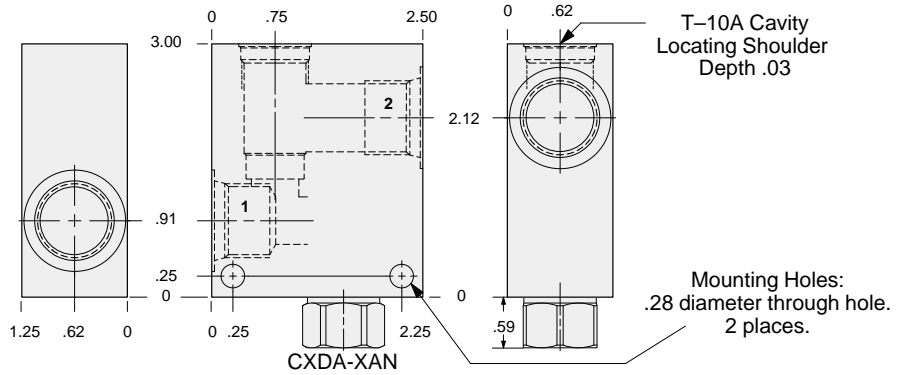

TYPICAL CARTRIDGES USED WITH THIS BODY

RPEC - ***	Page 1.06
RPEE - ***	Page 1.08
RDDA - ***	Page 1.10
RQEB - ***	Page 1.12
RBAC - ***	Page 1.16

Cartridge seal type determines check valve seal type.

Instructions for ordering complete cartridge and body assemblies. Page v

Pressure ratings, material specifications. Page 11.02

Ports 1 & 2	ALUMINUM		DUCTILE IRON	
	Part Number	List Price	Part Number	List Price
.25 NPTF	FNA		FNA/S	
.375 NPTF	FNB		FNB/S	
.50 NPTF	FNC		FNC/S	
SAE-6	FNI		FNI/S	
SAE-8	FNJ		FNJ/S	
SAE-10	FNK		FNK/S	
.25 BSPP	FNT		FNT/S	
.375 BSPP	FNU		FNU/S	
.50 BSPP	FNV		FNV/S	

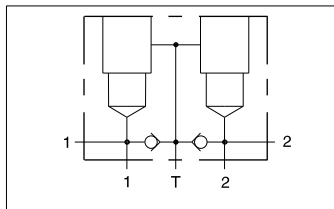

Two cavity body with make-up checks for cross-port relief applications.

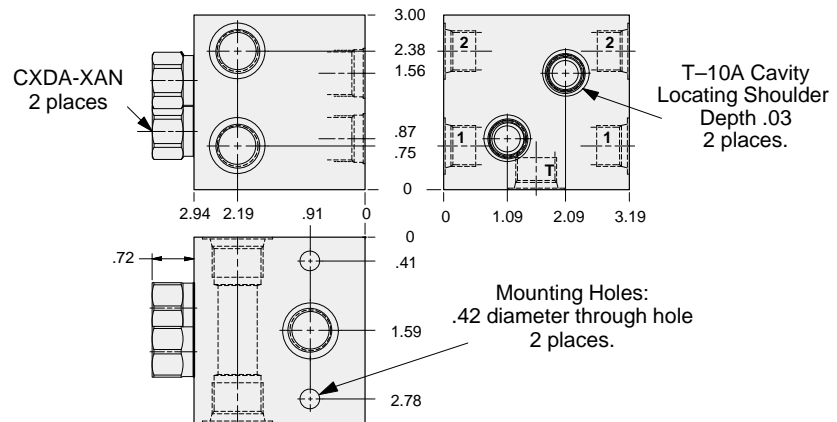

TYPICAL CARTRIDGES USED WITH THIS BODY

RPEC - ***	Page 1.06
RPEE - ***	Page 1.08
RDDA - ***	Page 1.10
RQEB - ***	Page 1.12

Cartridge seal type determines check valve seal type.

Instructions for ordering complete cartridge and body assemblies. Page v

Pressure ratings, material specifications. Page 11.02

Ports 1 & 2 & T	ALUMINUM		DUCTILE IRON	
	Part Number	List Price	Part Number	List Price
.25 NPTF	FMA		FMA/S	
.375 NPTF	FMB		FMB/S	
.50 NPTF	FMC		FMC/S	
SAE-6	FMI		FMI/S	
SAE-8	FMJ		FMJ/S	
SAE-10	FMK		FMK/S	
.25 BSPP	FMT		FMT/S	
.375 BSPP	FMU		FMU/S	
.50 BSPP	FMV		FMV/S	

S1
T10A